

DUAL CONSOLES



EXPRESS CABINS



GRADY-WHITE 2012



WALKAROUND CABINS



CENTER CONSOLES



We are delighted...

you are considering a Grady-White boat for your family! Our entire Grady-White team is focused on providing exceptional enjoyment and terrific value as part of our larger goal of delivering the ultimate boating experience.

One thing that really brightens our days is hearing about the wide variety of ways Grady-White boat owners enjoy time on and in the water. For well over 50 years we have delivered a superbly engineered, superior quality product that helps make priceless, long lasting memories. We appreciate the one-to-one relationships with dealers and customers that make possible, model year after model year, continuous innovations based on what customers tell us about how they use their boats and what they like and want to see in a Grady. We are proud of our longevity and the personal

connections that we have made over the years. These are tremendous assets and very rare things in any business.

For model year 2012, we're emphasizing our incredibly versatile *Freedom Series*, dual console models that bring a new level of "freedom" to the range of activities you can enjoy. Our *Freedom Series*, like all Grady-White boats, are great riding, safe, sure and saltwater tough, yet filled with features to do so many things well. We have not forgotten our legendary saltwater fishing heritage! Our express and walkaround cabin models, and *Fisherman* and *Canyon series* center consoles, including the brand new *Canyon 271* and the amazing *Canyon 366*, absolutely are second to none. If big water fishing or cruising is your passion, there is no better choice than a Grady-White.

No matter what your favorite water recreation or which waters you cruise, with 25 different models, there's a Grady-White that's just right for you. Each and every boat is built by, sold by and backed by the industry's best, most experienced craftsmen, associates, dealers and company managers. You can count on us!

Grady-White eagerly looks to the future. We know that for quality, safety, reliability, value and the ultimate in boating satisfaction, a Grady-White is and always will be in a class all its own. We hope that you will visit your local dealer to learn more about the models that interest you.

Chairman, CEO

President

The Grady Life friends like no



THE GRADY LIFE EXPERIENCE offers you, your family and friends the ultimate in boat ownership. Instead of relatives gathering only two or three times a year just for the major holidays, our boats and the "Grady Life" lifestyle make it special for everyone to be together a lot more often. With a boat this versatile, everyone can "do their own thing," and yet be together. Swimming, diving, all kinds of fishing, exploring, raft-ups, lunch or dinner cruises, camp-outs, wakeboarding and water skiing or just "sunnin' and funnin'"—these activities just scratch the surface of what Grady owners enjoy. No other outdoor recreation compares in diversity and fellowship with the Grady Life. You will feel confident and free to enjoy many adventures, and will reap enormous rewards. Together with our great dealers, we'll make your experience as carefree as possible!

Grady customers enjoy higher satisfaction primarily because of the company and dealers' commitment to providing the ultimate boating experience. The values, principles and systems with which we've operated for over 50 years, and the resulting relationships, help assure decades-long owner loyalty.

will connect family and other recreational activity.



Grady-White and Grady-White dealers aim for customer satisfaction that surpasses competitors' and exceeds expectation. Read or watch our customer testimonials online. Visit gradywhite.com often and view the Grady Life photos, or let the kids try out the activities on our Grady Kids web page. Page through our award-winning *Anchorline* newsletter, opt in on the website to subscribe to our very informative award-winning *e-Docklines*, and check the Grady Club, owner and dealer sites. Follow us on *Twitter* (twitter.com/gradylife) and/or enjoy the posts, videos and customer photos always updating on the official Grady *Facebook* page. Our customers just love to share stories about their great Grady moments and how well their boats perform! These reflections are not the only benchmarks of owner enjoyment. Every third-party measure ever conducted in our industry for our category has ranked Grady-White Boats at the highest levels.

"We've talked with other clubs' members and we unanimously agree that we've made the best friends we've ever had in our lives once we joined our Grady-White clubs."

—DOUG AND CAT COX, TARPON COAST AND TAMPA BAY GRADY-WHITE CLUBS MEMBERS

There are many annual Grady-White dealer events, tournaments, cruises and fishing schools enjoyed all over the country. The fabulous Grady Fest celebrates the boating lifestyle. A large and growing number of Grady-White Owners' Clubs share camaraderie throughout the year. There's a tremendous online resource center found at our website including many interesting customer tips about travel, cooking aboard, fishing, and customizing and maintaining your boat. The employees and associates of our privately held company—often with relationships that span many decades—actively keep in touch with you to hear about your great Grady days, and always look forward to hearing about special memories you make on the water with your family!

The colorful, versatile Grady Life. Hull colors now factory-available.*

With more requests for colored hulls, and taking into account the individuality, wide ranging interests and variety of activities enjoyed by today's customers, Grady-White now offers three colors of hull paint and a very sharp-looking gelcoat color as factory options in addition to our traditional classic Grady-White cream-colored hull.



Sand (gelcoat)

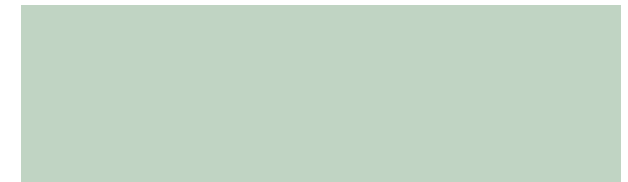

Sea Glass (paint)



Vista Blue (paint)



Harbor Blue (paint)

*Ink colors shown are approximate. See your dealer for actual color samples.

Grady-White: Historic highlights of a customer- and quality-focused company

1959

Glen Grady, Don White begin building small, tough, high quality wooden "works of art" for coastal boating that perform even in rough seas.

1968

Eddie Smith purchases Grady-White and completes the changeover to fiberglass production.

1972

Ground breaks for what remains today one of the most modern boat manufacturing facilities in the world.

1975

Grady-White introduces the *Hatteras 204-C Overnighter*, the company's first walkaround model.

Grady-Built: The finest materials for built-in value and security



A GRADY-WHITE IS NO ORDINARY CRAFT. Our 316-grade stainless steel hardware initially costs more than 304 grade because of the expensive nickel and chromium in the alloy, plus molybdenum.



Our patented fold away aft bench seat is a result of our process of seeking customers' advice on the kinds of material and detail that work best. Hardware and fixtures are placed right where you need them.

Cast parts are passivated in acid to remove casting impurities, then buffed, then passivated and buffed again. We test sample batches in our "instant ocean" salt bath. The result is hardware that's strong and durable even after years in a saltwater environment.

Whether we utilize a traditional glass laminate or a new composite or core material depends on the application. No matter which material we select, Grady-White's extensive in-house and on-the-water tests ensure long lasting value.

Cabins are handsome, with eye-pleasing fabrics. We test all appliances including microwaves, refrigerators, satellite radios, TVs, MP3 stereo output devices and DVD players. Fixtures are the best available.

Resin transfer molded (RTM) parts such as fish box lids, hardtops and bow pulpits are solid and durable. RTM is especially preferable for fish box lids because the smooth underside surface is easier to clean than the rough glass painted surfaces found on competitors' products.

Gunwale mounted rod holders are impervious to UV rays, and extra durable. Rod racks are sturdy and easily accessible.



The helm area is ergonomically designed and comfortable for ease of function and safety. The horn is the red button so you can find it. The windshield is engineered to enhance your field of vision and site lines. Always safety first on a Grady-White.

Super strong, durable polyethylene trim work and toe rails are tough, low maintenance and their good looks last.

Grab rails, handholds, handles, swim ladders and transom door latches are battleship-tough as are cleats and bow and stern eyes. Stainless lined drink holders are easy to clean. Durable materials give years of trouble-free use and that means a low cost of ownership.

1982

Grady-White's *Sailfish 25* ushers in the era of smaller outboard-powered offshore sportfishing boats.

1989

The *Marlin 28* introduces the SeaV²® hull, designed by C. Raymond Hunt Associates, delivering a soft, dry, true-tracking ride plus stability at lower speed.

1993

Kris Carroll, a Grady-White veteran, is named as Grady-White's new president.

2001

In the first J.D. Power and Associates study of the marine industry, Grady-White ranks "Highest in Customer Satisfaction with Center Console Boats."

Grady-Built: Built by craftsmen and superbly engineered through customer input

THE PEOPLE who design and engineer Grady-Whites are avid boaters themselves. Through ongoing contact with our boat owners, we create customer-driven designs that are constantly refined and thoroughly tested along the North Carolina coast to ensure superb performance in the toughest conditions.

Our production professionals are real craftsmen. Hand laid fiberglass provides an unmatched laminate structure. Only 100% hand lay-up assures a uniform thickness for strength and structural stiffness. Grady-White uses this tried and true method,



Our latest plant expansion further improved the most productive, efficient and completely integrated boatbuilding facility in the world today. This functionality assures the highest product quality and longest lasting value for our customers.



Customers tell us they like different seating choices, and no other brand offers as many options as Grady-White. Whether you opt for available flip-up bolsters (pictured above), deluxe seating (see options pages) or choose our standard seating, everyone will be very comfortable aboard your new Grady-White!

fitting patterned pieces of fiberglass to deliver consistent laminate thickness on every boat. The resin for every part is metered and measured so each has an optimal glass-to-resin ratio. Stringer systems are precision cut by computerized router and then glassed in while the hull is still in the mold so your SeaV² hull retains the correct shape. Our proven stringer grid system is consistently strong, light, phenomenally durable, and has a limited lifetime warranty. Closed cell foam sprayed in between the stringers adds strength and augments flotation.

Super strong transoms are not only solidly Grady-Built of the strongest materials, but also

reinforced with an angled aluminum brace to provide sure support for today's four-stroke engines. This bracing supports the top motor hole mounts, distributing torque throughout the transom.

At the helm threshold of our cabin models, decks are joined to liners with double through bolting. Aft of the seat boxes, another through-bolted and fiberglassed system forms a "box grid" to secure the deck and liner together, giving Grady-Whites support not found

in other boats. All these factors add up to many years of enjoyment!



Skilled craftsmen apply hand laid fiberglass with precisely the right thickness and resin ratios. Top quality components assembled with skill result in quality, reliability and performance over the long haul.

2002

Express 330 named Boating Magazine "Boat of the Year." Grady-White ranks "Highest in Customer Satisfaction With Coastal Fishing Boats Two Years In A Row."

2003

Plant expansion provides customers with even greater quality and value. Grady-White ranks "Highest in Customer Satisfaction With Coastal Fishing Boats Three Years In A Row."

2005

Express 360 introduced, setting new benchmark for boating. GW ranks "Highest in Customer Satisfaction With Coastal Fishing Boats Four Times in a Row."

2007

Express 305 introduced. *Canyon 336* debuts, incorporates cabin comfort in a center console. GW ranks "Highest in Customer Satisfaction With Coastal Fishing Boats (17-28 feet) Six Times in a Row."

Grady-Built: Our exclusive SeaV²[®] hull design is the ultimate in offshore performance.



THERE IS NO RIDE like Grady-White's. Often imitated but never equaled, our exclusive SeaV² hull offers the industry's best combination of dryness, seakeeping performance

and speed. Grady-White factory rigs four-stroke engines exclusively so the SeaV² hull as well as fuel tank position are especially well balanced for the optimum performance of these new power sources. Unlike other brands, a SeaV²

hull design has no two places on the keel where the deadrise is the same. The vee continuously sharpens from the transom to the bow stem. A SeaV² hull design with 20 degrees of deadrise at the transom will have around 30 degrees amidships-more than even the most radical older deep vee designs. The



Look carefully at a Grady-White running. You can actually see three wakes coming off the hull. This is a reflection of the smooth, dry trademark Grady-White SeaV²[®] ride.

quartering seas and especially in following seas. There are no rounded shapes to behave like a ball in the water that knows no upright position.

Strakes and chines knock the spray down cold. Check the spray coming off a SeaV² hull. You can actually see three bow wakes in smooth water. Those are the individual deflectors working. This is the reason SeaV² hulls are drier running than boats with rounded sections that blow spray past the strakes and chines and into the cockpit.

Grady-White delivers a deep vee ride with

deeper vee forward means a softer ride at sea. Less vee at the transom coupled with wide chines provide stability at rest and when trolling.

A SeaV² hull tracks as if the boat is on rails. The series of wedges that form a SeaV² hull have tremendous righting force providing incredible tracking in

modified vee efficiency. Unlike other deep vee hulls, SeaV² hulls provide a soft ride without fuel efficiency loss. A SeaV² hull slices through seas effortlessly with a sharp point of entry, and the varying deadrise builds buoyancy that lifts the boat as it proceeds through waves. The result: better performance.

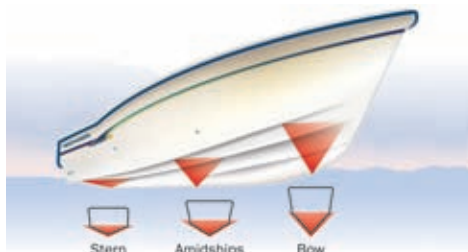

Like a series of sea-cutting wedges

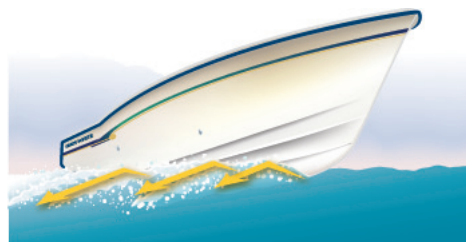

Strakes and chines knock down spray



Tracks in quartering seas

2009

Grady-White celebrates 50th anniversary. Ranks "Highest in Customer Satisfaction With Coastal Fishing Boats (17-30 feet) Eight Times in a Row."

2010

Fisherman 230 and *Canyon 366* debut; center consoles 28'-36' become *Canyon Series*. 2010 NMMA CSI (9th in a row) continues unbroken string of every industry award for customer satisfaction.

2011

Freedom Series dual consoles bring new level of recreational versatility to coastal boating. Grady center consoles 18'-27' now comprise *Fisherman Series*.

2012

Canyon 271 introduction reaffirms Grady's commitment to saltwater fishing heritage, while the *Freedom Series* grows ever-popular thanks to ultra versatility.

Fisherman 180

18' CENTER CONSOLE

“Our 180 really suits our family of four, now plus Mauser our German Shepherd buddy, who loves his Grady rides on Puget Sound!”

—SCOTT AND KRISTI URQUHART, EDMONDS, WA 180 FAMILY

For detailed specifications see page 38.

Beam Amidships: 7'5" (2.26 m)
 Bridge Clearance: 5'7" (1.70 m)
 Center Line Length: 17'10" (5.44 m)
 Hull Draft: 15" (0.38 m)
 Maximum HP: 150 (112 kW)
 Weight w/o Engine: 2150 lb. (975 kg)

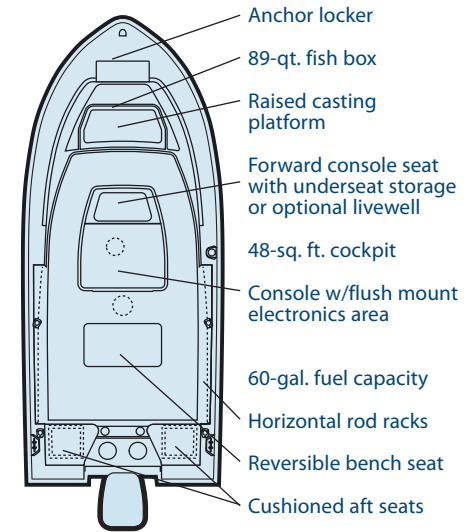

Bow fish box



Bow casting platform



Forward console with seating and bow anchor locker



Console with flush mount electronics area

Freedom 192

19' DUAL CONSOLE

"I fell in love with Grady's at an early age. I am military and now live close enough to the water to spend family time on our 192. Thanks for posting pictures of my boy and little girl on your website!"

—NATHANAEL KARRS, CALEDONIA, MS 192 OWNER

For detailed specifications see page 38.

Beam Amidships: 8' (2.44 m)
 Bridge Clearance: 4'9" (1.45 m)
 Center Line Length: 19'2" (5.84 m)
 Hull Draft: 14" (.36 m)
 Maximum HP: 150 (112 kW)
 Weight w/o Engine: 2475 lb. (1123 kg)

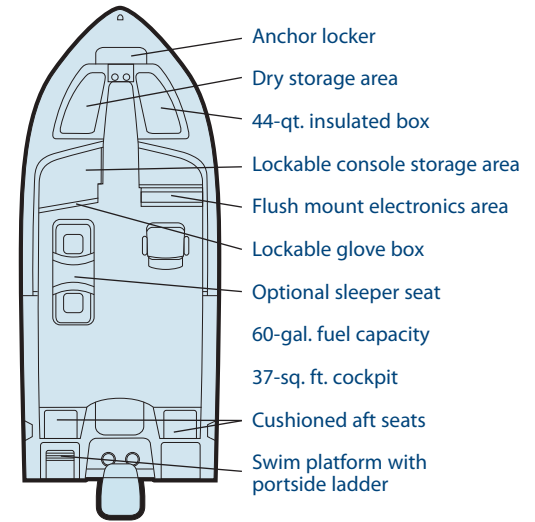

Cockpit forward with optional port sleeper seat



Bow anchor locker



Cushioned aft seating showing optional ski pylon deck mount



Cockpit shower



Helm station with flush mount electronics area



Bow seating with port dry storage and starboard ice box. Shown with forward bolsters and optional stereo speakers.

Freedom 205

20' DUAL CONSOLE

"I absolutely love my boat. It's versatile, great for fishing out on the open water of the Georgian Bay here in Ontario and great for pike fishing in shallow water, too. Great for the family—we pack a picnic, go tubing out on the lake, then anchor and take a swim and relax."

—JOHN WELSH, POINTE AU BARIL, ONTARIO 205 OWNER

For detailed specifications see page 38.

Beam Amidships: 8'1" (2.46 m)
 Bridge Clearance: 5'7" (1.70 m)
 Center Line Length: 20'4" (6.20 m)
 Hull Draft: 15" (0.38 m)
 Maximum HP: 250 (187 kW)
 Weight w/o Engine: 2810 lb. (1275 kg)

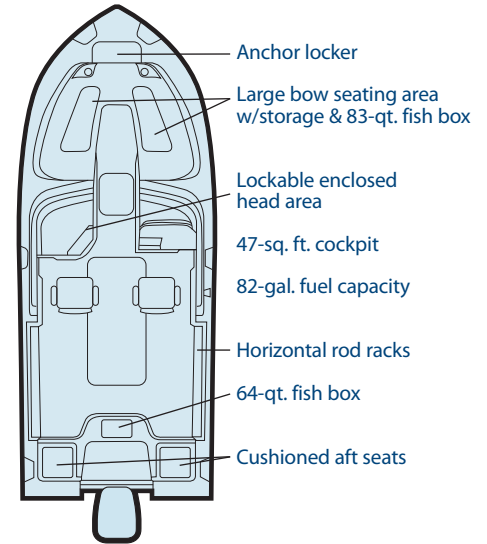

Cockpit forward with optional port sleeper seat



Lockable enclosed head area with storage nets



Forward seating with insulated fish box



Helm station

Adventure 208

20' WALKAROUND CABIN

"My 208 is a very secure platform with dry areas for the sonar gear and electronics I use in my dives. I like the cabin for camping, and the open deck has plenty of room. I have never had a problem with any of my four Gradys. My wife, sons and my dog love our boat!"

—PAUL BROWN, SAN DIEGO, CA ADVENTURE 208 FAMILY

For detailed specifications see page 38-39.

Beam Amidships: 8'1" (2.46 m)
 Bridge Clearance: 5'9" (1.75 m)
 w/Hardtop: 8' (2.44 m)
 Center Line Length: 20'4" (6.20 m)
 Hull Draft: 15" (0.38 m)
 Maximum HP: 250 (187 kW)
 Weight w/o Engine: 2900 lb. (1315 kg)

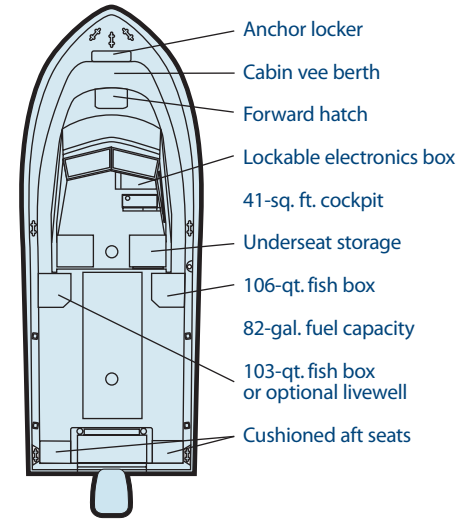

Cockpit forward with optional cockpit bolsters



Helm station with lockable electronics box



Cushioned aft seating



Cabin interior shown without auxiliary berth cushions; optional portable head

Fisherman 209

20' CENTER CONSOLE

"My six-year-old son caught his first albacore on our 209. Needless to say he was very excited."

—JAMES MOTT, SAN ANSELMO, CA 209 OWNER

For detailed specifications see page 39.

Beam Amidships: 8'1" (2.46 m)
 Bridge Clearance: 6'4" (1.95 m)
 w/T-top: 7'9" (2.36 m)
 Center Line Length: 20'4" (6.20 m)
 Hull Draft: 15" (0.38 m)
 Maximum HP: 250 (187 kW)
 Weight w/o Engine: 2600 lb. (1179 kg)

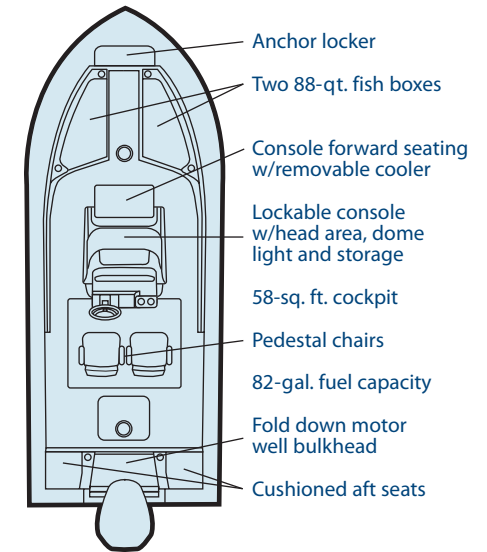

Console head area/storage compartment with dome light; optional portable head

Helm with optional T-top and deluxe lean bar with flip-up bolster

Forward port and starboard fish boxes with cushions; optional forward bolsters



Optional deluxe lean bar with rod holders; aft cushioned seats and fold down motorwell bulkhead; optional cockpit bolsters

Freedom 225

22' DUAL CONSOLE

"I have all the confidence in the world in my boat, my dealer and Grady-White! We'll load the grandkids and take a ride to Blackbeard Island for a great day at the coast. My 225 has kept me safe in seven-foot waves and yet it's also great exploring the backwaters here in South Georgia."

—MIKE FLY, SOUTHERLAND BLUFF, GA 225 OWNER

For detailed specifications see page 39.

Beam Amidships: 8' (2.44 m)
 Bridge Clearance: 5'6" (1.68 m)
 Center Line Length: 22'2" (6.76 m)
 Hull Draft: 16" (0.41 m)
 Maximum HP: 300 (224 kW)
 Standard Fuel Capacity: 96 gal. (363 l)
 Transom Width: 7'11" (2.41 m)
 Weight w/o Engine: 3450 lb. (1565 kg)

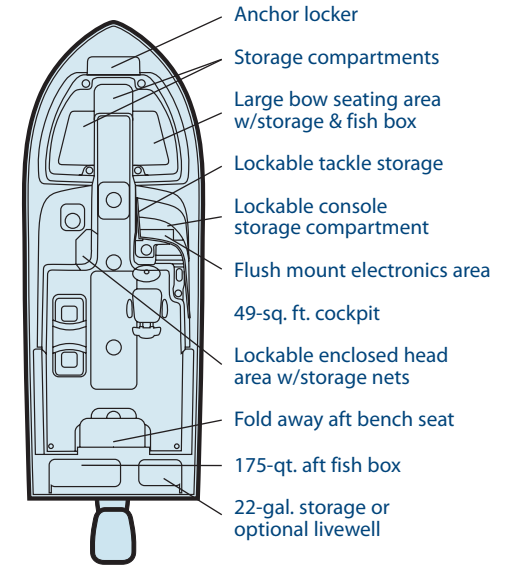

Cockpit forward with optional port sleeper seat, Deluxe II helm chair and cockpit bolsters

Lockable enclosed head area and portable head



Transom with fold away bench seat, fish box and optional livewell

Optional soft top arch with ivory canvas



Seafarer 226/228

22' WALKAROUND CABIN

“Our family has great fishing trips on Lake Erie on our *Seafarer 228*. My wife and son have big smiles and a good catch!”

—JOE DASILVA, ANN ARBOR, MI SEAFARER 228 OWNER

For detailed specifications see page 40.

Beam Amidships: 8' (2.44 m)

Bridge Clearance: 6'2" (1.88 m)

w/Hardtop: 8'4" (2.54 m)

Center Line Length: 22'2" (6.76 m)

Hull Draft: 16" (0.41 m)

Maximum HP: 300 (224 kW)

Weight w/o Engine:

226 (standard transom): 3385 lb. (1535 kg)

228 (Grady Drive transom): 3510 lb. (1592 kg)

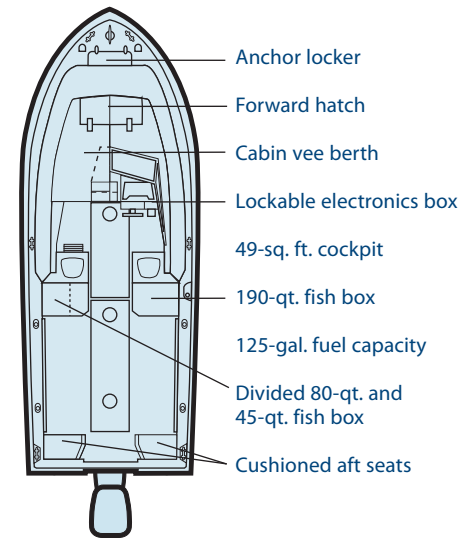

Cabin interior shown with standard auxiliary berth cushions (sink not shown)



Helm station with lockable electronics box



Cabin access forward between helm and companion seats

Fisherman 230

23' CENTER CONSOLE

"I can fly fish at the bow without snagging my line, and the deep cockpit is very safe. We like to cruise to restaurants with other couples, and there's plenty of seating."

—RODGER AND BETTY HESS, NEW YORK CITY/JUPITER, FL
FISHERMAN 230 OWNERS

Shown with optional T-top. For detailed specifications see page 40.

Beam Amidships: 8'6" (2.59 m)
 Bridge Clearance: 6'8" (1.88 m)
 w/T-top: 8'5" (2.57 m)
 Center Line Length: 22'8" (6.9 m)
 Hull Draft: 20" (.51 m)
 Maximum HP: 300 (224 kW)
 Weight w/o Engine: 4002 lb. (1815 kg)

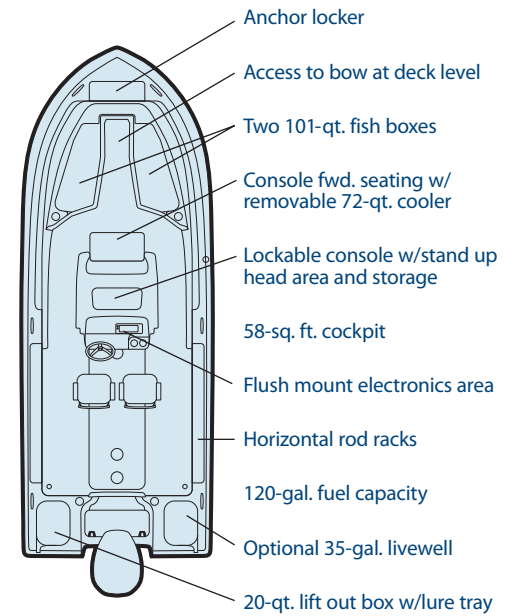

Helm showing footrest, flush mount electronics kit, acrylic windshield and optional T-top with radio box



Optional deluxe lean bar with backrest and flip-up bolster



Optional removable center bow casting platform w/cushion



101-qt. (96 l) port and starboard forward insulated fish boxes w/ob drain. Access to bow at deck level.

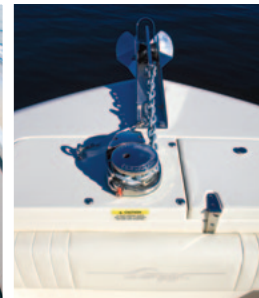

Bow anchor locker with optional anchor windlass



72-qt. (68 l) removable cooler seat forward (cooler upgrade shown)



Optional patented aft fold away bench seating with cushion

Gulfstream 232

23' WALKAROUND CABIN

“Our children enjoyed us taking their younger cousin on his first Grady excursion to see the bonfires and fireworks for July 4th! Our family of five loves cruising the south shores of Boston on our *Gulfstream 232*. This is our third Grady-White.”

—PAUL BARRY, SCITUATE, MA GULFSTREAM 232 FAMILY

Shown with optional hardtop. For detailed specifications see page 40-41.

Beam Amidships: 9'3" (2.82 m)

Bridge Clearance: 6'5" (1.96 m)

w/Hardtop: 8'8" (2.64 m)

Center Line Length: 23'5" (7.14 m)

Hull Draft: 20" (0.51 m)

Maximum HP: 400 (298 kW)

Weight w/o Engine:

232S: 4538 lb. (2058 kg)

232D: 4605 lb. (2089 kg)

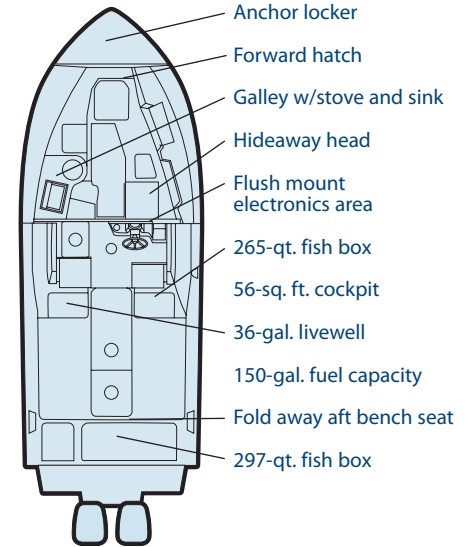

Helm area with optional Deluxe II helm chairs



Fold away aft bench seat



36-gallon (136.3 l) livewell and tackle drawers



Helm station with flush mount electronics area

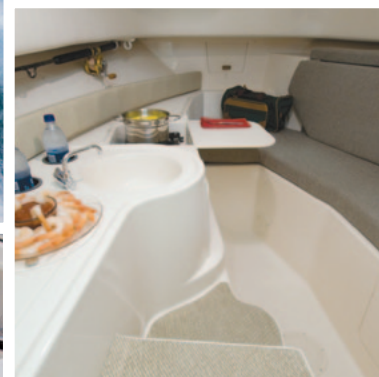

Cabin interior shown without auxiliary berth cushions



Head area in lockable cabin, with fold down cover; optional electric marine head shown

Freedom 255

25' DUAL CONSOLE

"The 255 is the ultimate in versatility. We've pulled back the Bimini top for cocktail cruises, and battened down the hatches chasing rockfish 60 miles through a snowstorm. This boat is fast, economical and very comfortable (with a surprisingly spacious head area). We are really enjoying our first Grady!"

—JIMMY AND CINDY NASH, VIRGINIA BEACH, VA *FREEDOM 255 OWNERS*

For detailed specifications see page 41.

Beam Amidships: 8'6" (2.59 m)
 Bridge Clearance: 5'7" (1.70 m)
 w/Hardtop: 7'8" (2.34 m)
 Center Line Length: 24'9" (7.55 m)
 Hull Draft: 20" (.51 m)
 Maximum HP: 350 (261 kW)
 Weight w/o Engine: 4459 lb. (2023 kg)

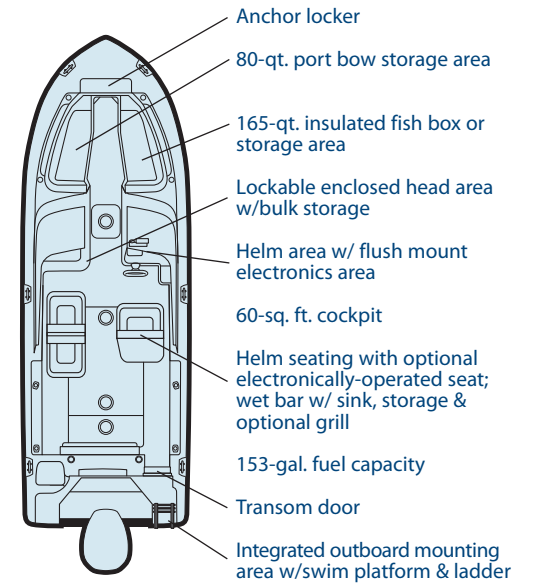

Cockpit forward



Optional port sleeper seat with storage



Bow seating area with cushions, bolsters and optional stereo speakers

Lockable enclosed head with storage nets; optional marine head shown



Transom with fold away bench seat



Optional hardtop available

Fisherman 257

25' CENTER CONSOLE

"I love that our 257 allows us to fish off the beach at Cape Cod for stripers and blues, and go into deepwater for bluefin tuna. We like whale watching, too."

—JOHN PLANSKY, LEXINGTON, MA 257 OWNER

Shown with optional T-top. For detailed specifications see page 41.

Beam Amidships: 8'6" (2.59 m)
 Bridge Clearance: 7' (2.13 m)
 w/T-top: 8'6" (2.59 m)
 Center Line Length: 24'9" (7.55 m)
 Hull Draft: 20" (0.51 m)
 Maximum HP: 350 (261 kW)
 Weight w/o Engine: 4045 lb. (1835 kg)

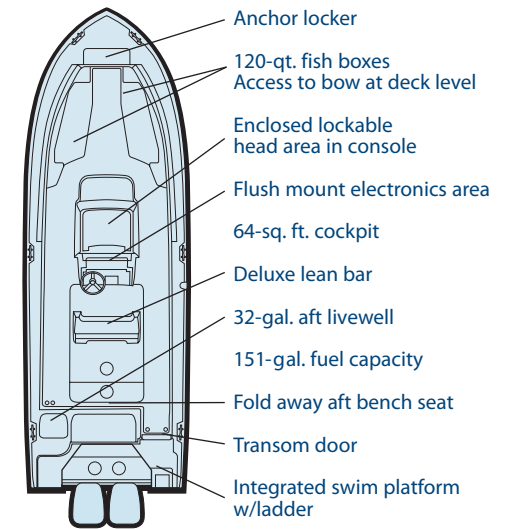

Lockable stand up console head enclosure with storage shelves and hanging locker; shown with optional portable head



Bow seating with insulated storage



Deluxe lean bar with footrest, backrest and fold down bolster



Helm with flush mount electronics area



Transom area with transom door, swim ladder, fold aft bench seat, 185-quart insulated fishbox, 32-gallon livewell

Journey 258

25' WALKAROUND CABIN

“My 258 is fantastic for tuna fishing in the Otranto Channel, where weather conditions can change quickly. I have confidence in the safety and seaworthiness of my boat.”

—FEDERICO ERRICO, BARI, ITALY JOURNEY 258 OWNER

Beam Amidships: 8'6" (2.59 m)
 Bridge Clearance: 6'6" (1.98 m)
 w/Hardtop: 8'8" (2.64 m)
 Center Line Length: 24'9" (7.55 m)
 Hull Draft: 20" (0.51 m)
 Maximum HP: 350 (261 kW)
 Weight w/o Engine: 4320 lb. (1960 kg)

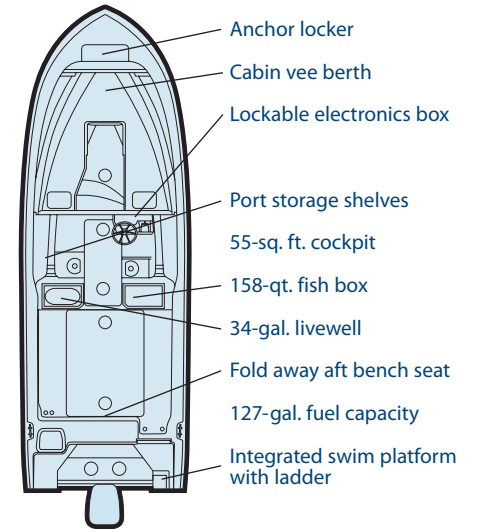

Shown with optional hardtop. For detailed specifications see page 42.



Helm station with lockable electronics box



Aft cockpit with insulated box, cockpit shower and folding aft bench seat



158-quart starboard insulated fish box with overboard drain



Cabin interior shown with auxiliary berth cushions

Canyon 271

27' CENTER CONSOLE

“The 271 is a perfect addition to our *Canyon Series* of offshore-oriented center console boats. The *Canyon 271* features Grady-White’s sweet-riding SeaV² hull on an unparalleled sportfishing platform. Here’s a boat that offers 360° movement at deck level plus the seating and amenities—including a head—that assure many great days of all-around family fun.”

—DAVID NEESE, GRADY-WHITE VICE PRESIDENT ENGINEERING

Shown with optional T-top. For detailed specifications see page 41.

Beam Amidships: 9'6" (2.89 m)
 Bridge Clearance: 6'11" (2.11 m)
 w/T-top: 8'2" (2.49 m)
 Center Line Length: 26'10" (8.18 m)
 Hull Draft: 23" (0.58 m)
 Maximum HP: 600 (441 kW)
 Weight w/o Engine: 5790 lb. (2626 kg)

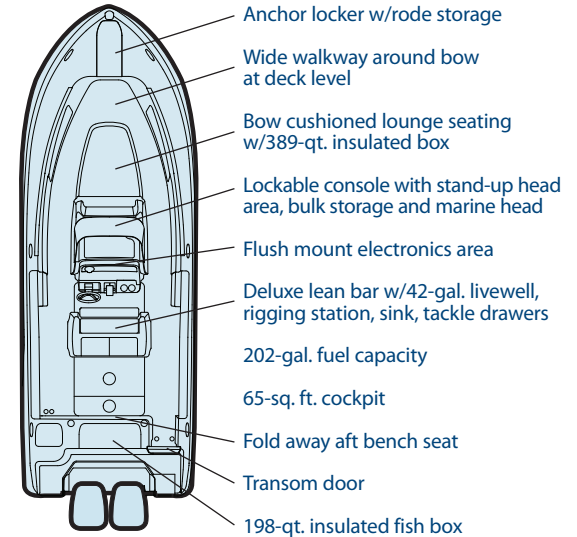

Helm with flush mount electronics area and footrest



Deluxe lean bar w/42-gallon livewell, rigging station, sink, tackle drawers



389-qt. insulated box w/removable divider, under bow cushioned lounge seat



Lockable console w/stand up head area, bulk storage & marine head w/ macerator, 10-gallon (37.9 l) holding tank & pump out



Fold away aft bench seat

Freedom 275

27' DUAL CONSOLE

"I've been boating all my life, and the 275 is the greatest boat I've ever owned. The layout is absolutely perfect for someone who enjoys pleasure cruising, fishing and taking the kids tubing and skiing. The stability and responsiveness are amazing."

—MELVIN CLINE, CHESAPEAKE BEACH, MD 275 OWNER

Shown with optional hardtop. For detailed specifications see page 42-43.

Beam Amidships: 8'6" (2.59 m)
 Bridge Clearance: 6'4" (1.93 m)
 w/Hardtop: 8'6" (2.59 m)
 Center Line Length: 26'11" (8.20 m)
 Hull Draft: 20" (0.51 m)
 Maximum HP: 500 (373 kW)
 Weight w/o Engines: 4972 (2255 kg)

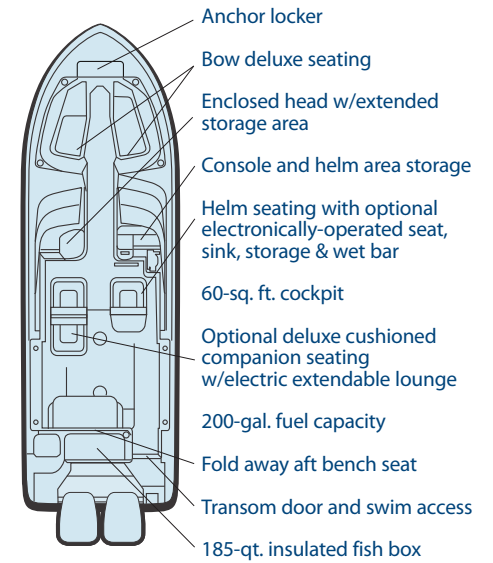

Starboard console dry storage



Aft fold away bench seating, 185-quart insulated fish box, and 128-quart cooler (32-gallon livewell optional)



Head area with extended storage, shown with optional electric marine head



Deluxe cushioned bow seating with table (doubles as cockpit area table)



Cockpit shown with optional port electric extendable lounge seating

Canyon 283

28' CENTER CONSOLE

“The 283 is my sixth Grady-White. I wanted a fast boat to reach the Keys but not something too big. The 283 is a perfect combination of a long range boat for the open water and one that my wife and I can take out every day for cruising. I looked at two other makes, but Grady had the best handling, level of quality and solid engineering.”

— REESE KAUFFMAN, SANIBEL, FL 283 OWNER

Beam Amidships: 9'6" (2.90 m)
 Bridge Clearance: 7'7" (2.31 m)
 w/T-top: 9' (2.74 m)
 Center Line Length: 28' (8.53 m)
 Hull Draft: 20" (0.51 m)
 Maximum HP: 600 (448 kW) w/V6 engines only
 Weight w/o Engines: 5864 lb. (2660 kg)

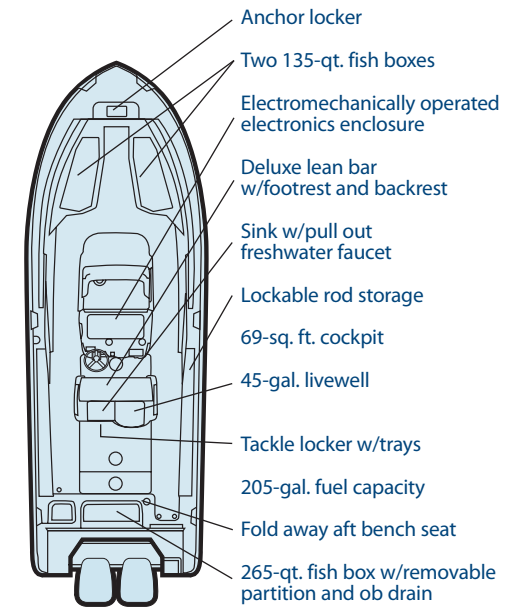

Shown with optional T-top. For detailed specifications see page 43.



Lockable head enclosure with fold down cover, sink and storage



Bow insulated fish boxes with optional casting platform insert



Helm console with electromechanically operated lockable electronics enclosure



Chesapeake 290

29' WALKAROUND CABIN

“We’ve always wanted to cruise farther west to places like the Gulf Islands, and now with the 290 we can. Our girls love the cabin, and the first day we were out Melanie caught a 22-pound chinook salmon—her biggest ever.”

—DR. KURT AND MELANIE TSUYUKI, SURREY, BRITISH COLUMBIA
CHESAPEAKE 290 OWNERS

*Shown with optional hardtop-mounted rod holders.
For detailed specifications see page 43.*

Beam Amidships: 9'11" (3.02 m)
 Bridge Clearance w/Hardtop: 9'9" (2.97 m)
 Center Line Length: 28'6" (8.69 m)
 Length Overall (w/bow roller): 29'9" (9.07 m)
 Hull Draft: 24" (0.6 m)
 Maximum HP: 600 hp (448 kW)
 Weight w/o Engines: 7650 lb. (3470 kg)

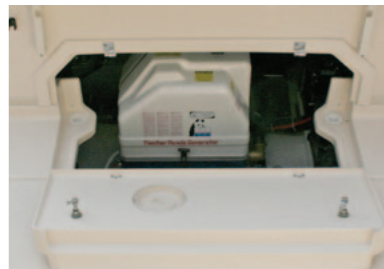
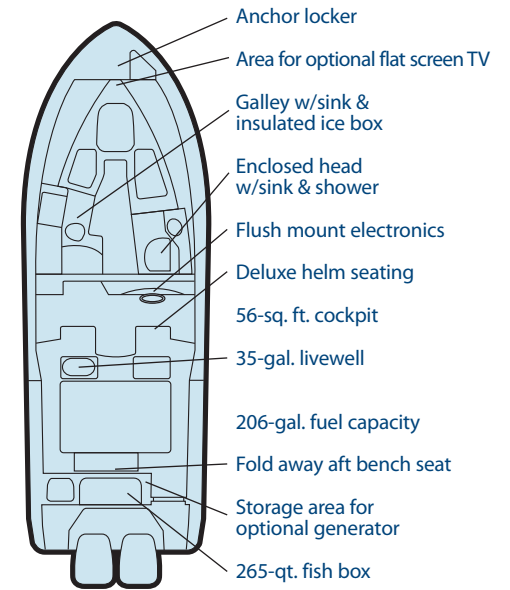

Optional Deluxe III helm chair w/flip-up bolster

Fold away aft bench seat

Easy access for optional generator

Cabin interior with galley, cherry table, vee berth and teak and holly sole

Marlin 300

30' WALKAROUND CABIN

“Our family has owned several *Marlin 300* models, logging hundreds of happy hours. When my first son was born, we named him Grady!”

—KEITH FRANTZ, HICKMAN, CA *MARLIN 300* FAMILY

For detailed specifications see page 44.

Beam Amidships: 10'7" (3.23 m)
 Bridge Clearance w/Hardtop: 9'9" (2.97 m)
 Center Line Length: 30'6" (9.30 m)
 Length Overall (w/pulpit): 32'7" (9.93 m)
 Hull Draft: 23" (0.58 m)
 Maximum HP: 700 (522 kW)
 Weight w/o Engines: 8221 lb. (3729 kg)

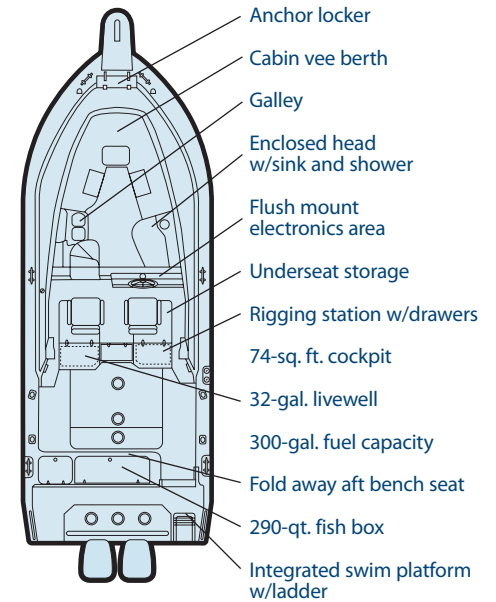

Cabin interior featuring galley, cherry dinette table, teak and holly sole, vee berth and enclosed head



Cockpit forward showing helm area and seating



Fold away bench seat, transom door, fish box and lift out box



Aft double berth with storage nets

Express 305

30' EXPRESS CABIN

“My husband and I love fishing aboard our *Express 305, Reel Mambo*. We are able to chase those stripers and blues around the Long Island Sound with great ease and speed, and sleep comfortably aboard in the evening. Look for me out there—I am the lady with the pink fishing rod bending in the ocean! This is our second Grady, and just like our fish we want one bigger each season.”

—JANET FRANCO, CHAPPAQUA, NY EXPRESS 305 OWNER

For detailed specifications see page 44-45.

Beam Amidships: 10'7" (3.23 m)
 Bridge Clearance w/Hardtop: 9'9" (2.97 m)
 Center Line Length: 30'6" (9.30 m)
 Length Overall (w/pulpit): 32'7" (9.93 m)
 Hull Draft: 23" (0.58 m)
 Maximum HP: 700 (522 kW)
 Weight w/o Engines: 8850 lb. (4014 kg)

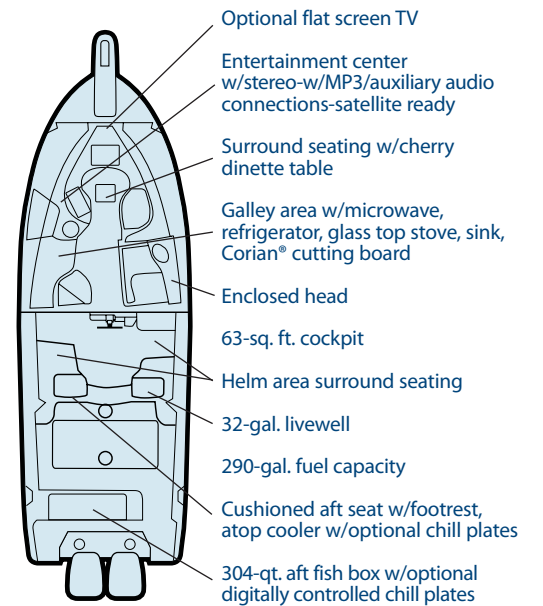

Cockpit forward with transom door



Cabin interior featuring galley, cherry dinette table, teak and holly sole



Lockable head enclosure with shower and bulk storage



Easy access for optional generator



Helm station with electromechanically operated lockable electronics enclosure

Canyon 306

30' CENTER CONSOLE

"We love to fish for king mackerel and the 306 is really a great offshore boat. But take the rods off, and it's really family ready, full of creature comforts. With the spacious console and comfortable seats and bow cushions, my wife and three-year-old enjoy great afternoon and evening picnics."

—BRANDON MALLARD, GEORGETOWN, SC 306 OWNER

Shown with optional T-top. For detailed specifications see page 45.

Beam Amidships: 10'7" (3.23 m)

Bridge Clearance: 7'3" (2.21 m)

w/T-top: 9'4" (2.84 m)

Center Line Length: 30'6" (9.30 m)

Hull Draft: 21" (0.53 m)

Maximum HP: 700 (522 kW)

Weight w/o Engines: 6950 lb. (3152 kg)

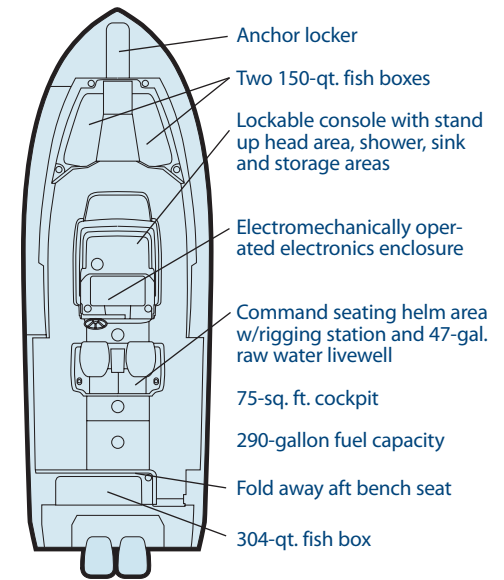

Helm console with electromechanically operated lockable electronics enclosure



Command seating helm area with two deluxe adjustable sliding chairs, rigging station with freshwater sink, pullout faucet and insulated livewell



Lockable head enclosure with fold down cover, sink and storage



Anchor locker with windlass



304-quart aft insulated fish box, transom door and folding aft bench seat

Freedom 307

30' DUAL CONSOLE

“My brother, our sons and I had a double blue marlin day off the north side of St. Lucia aboard my 307. One was just over 300 pounds. This is a great boat for family day cruising as well as fishing. This is my third Grady, and I would never consider another make.”

—JOHN RITTENHOUSE, LONDON, ENGLAND/GROS ISLET, ST. LUCIA
FREEDOM 307 OWNER

Shown with optional hardtop. For detailed specifications see page 45.

Beam Amidships: 10'7" (3.23 m)
 Bridge Clearance: 6'11" (2.11 m)
 w/Hardtop: 8'10" (2.69 m)
 Center Line Length: 30'6" (9.30 m)
 Hull Draft: 22" (0.56 m)
 Maximum HP: 700 (522 kW)
 Weight w/o Engines: 7850 lb. (3561 kg)

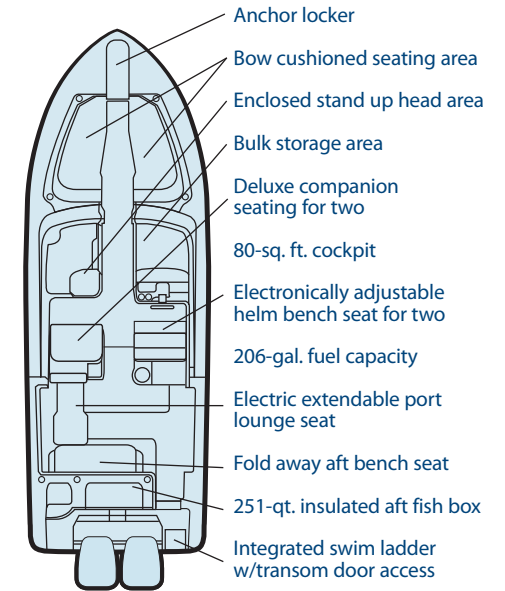

Deluxe bar showing refrigerator option (see page 37 for optional grill)



Stand up head area with bulk storage; fold down head cover creates 5' berth.



Deluxe cushioned bow seating with table (doubles as a cockpit area table)



Cockpit forward showing companion seating area with electric extendable lounge seating. The standard bar (w/o grill option) includes a fiberglass storage bin under the Corian® bar top.



GRADY-WHITE

YAMAHA

Express 330

33' EXPRESS CABIN

"We were looking for a boat that would be perfect for completing America's Great Loop, and fell in love with the *Express 330*."

—CHRIS BRANCH AND RUSS OTTERBINE, BOYNE CITY, MI/OLDSMAR, FL
EXPRESS 330 OWNERS

Beam Amidships: 11'7" (3.53 m)
 Bridge Clearance w/Hardtop: 9'10" (3.00 m)
 Center Line Length: 33'6" (10.21 m)
 Length Overall (w/pulpit): 35'10" (10.92 m)
 Hull Draft: 25" (0.64 m)
 Maximum HP: 700 (522 kW)
 Weight w/o Engines: 10,840 lb. (4917 kg)

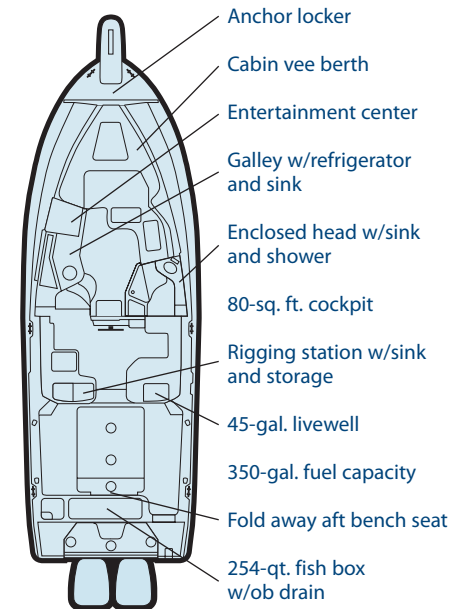

Shown with optional 15-ft. outrigger. For detailed specifications see page 46.



Optional hardtop enclosure



Helm area surround seating shown with optional Deluxe Platinum helm chair



Starboard helm surround seating (middle cushion area folds down)



254-quart aft deck insulated fish box



Helm console with electromechanically operated lockable electronics enclosure



Easy access for standard generator



Port side tackle station and sink



Head enclosure with extensible shower faucet



Cabin interior showing aft double berth



Cabin interior featuring galley with refrigerator and microwave and flat screen 15" LCD TV w/DVD player and audio visual inputs



Cabin interior with cherry table and teak and holly sole

Canyon 336

33' CENTER CONSOLE

"I've had five boats including large inboards, and the Canyon 336 is by far the best combination of hull, power and accommodations I have ever experienced. It's perfect whether I am scuba diving, or fishing with my friends, or just enjoying the day on the water with my wife and family. The anchoring system is superb."

-NORM CHAMBERS, GLOUCESTER, MA CANYON 336 OWNER

Shown with optional T-top. For detailed specifications see page 46.

Beam Amidships: 11'7" (3.53 m)

Bridge Clearance: 8' (2.44 m)

w/T-top: 9'2" (2.79 m)

Center Line Length: 33'6" (10.21 m)

Hull Draft: 25" (0.64 m)

Maximum HP: 700 (522 kW)

Weight w/o Engines: 9200 lb. (4173 kg)

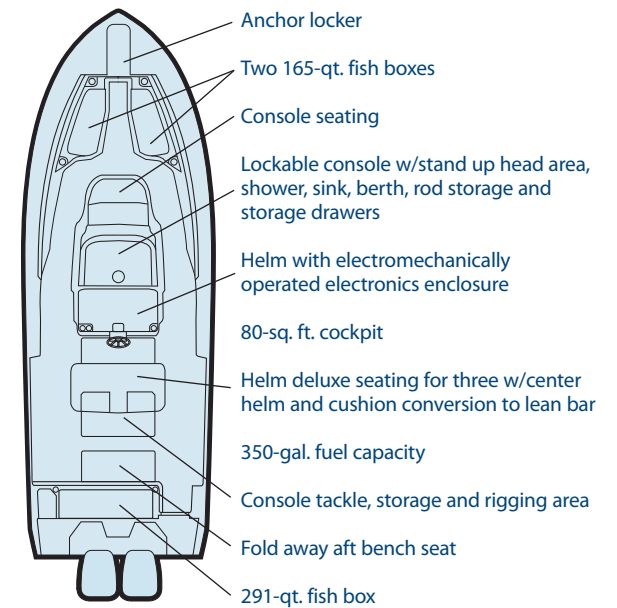

Lockable console interior with stand up head, shower, sink, rod storage, bulk storage and electrical access



Rigging station with freshwater washdown, 104-quart cooler, tackle drawers, storage, rod holders and knife & pliers holder



Center helm lean bar with three deluxe sliding seats and footrest, electromechanically operated lockable electronics enclosure



Bow casting area with optional platform insert and cushions



Console forward berth



GRADY-WHITE

YAMAHA

Express 360

36' EXPRESS CABIN

“Our family of five spent a month in the Bahamas on our *Express 360*, and everyone was totally comfortable. We covered over 1500 miles at average cruising speeds of 25-31 mph.”

—SCOTT AND ANJA BRANE, CLEARWATER, FL *EXPRESS 360 OWNERS*

Optional hardtop-mounted 24-foot outriggers shown.
For detailed specifications see page 46-47.

Beam Amidships: 13'2" (4.01 m)
 Bridge Clearance w/Hardtop: 10'6" (3.20 m)
 Center Line Length: 36'7" (11.15 m)
 Length Overall (w/pulpit): 39'3" (11.96 m)
 Hull Draft: 29" (0.74 m)
 Maximum HP: 1050 (783 kW)
 Freshwater Capacity: 65 gal. (246 l)
 Weight w/o Engines: 14,919 lb. (6767 kg)

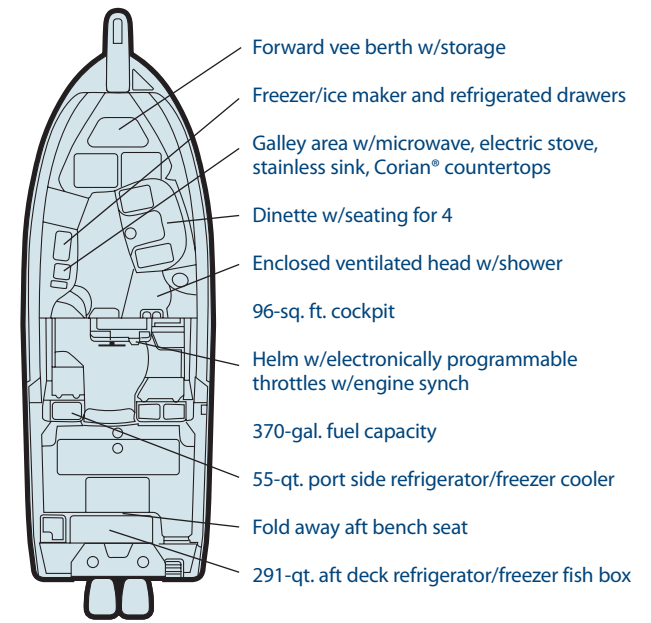

360 shown with optional hardtop enclosure



Aft berth includes 56" x 84" sleeping area with privacy curtain, teak foot well, cherry hanging locker with cedar lining, bulk storage, six rod holders.



Head/shower area includes sink with Corian® counter surface, separate shower area with curtain, teak grate over shower drain, full length mirror, VacuFlush® head, lighted vanity mirror, cherry shelves, storage areas.

Helm surround seating includes innovative slide-away table, chart/storage area, additional fold away seating and deluxe cushioning.



Main cabin includes teak and holly sole, seating for four at cherry dinette table, variable accent lighting, 16,000 BTU air conditioning with zone cooling, expansive forward berth with storage and privacy curtain, and cherry enclosed storage areas.



Cockpit forward showing 96-sq. ft. cockpit, helm station with deluxe chair, and port and starboard lounge seating



Helm includes deluxe adjustable seating, power assisted tilt steering, electronically programmable throttles with engine synch mode, electromechanically operated electronics enclosure, and easy-access accessory fuse compartment.



291-qt. aft deck refrigerator/freezer fish box (shown) along with 55-qt. refrigerator/freezer aft helm port box (not shown), both controlled by digital thermostat. Chill coils are located in the walls of foam insulated boxes, increasing efficiency and greatly reducing the need for ice. Coil configuration and overboard drains keep boxes clean, open and easy to maintain.



Canyon 366

36' CENTER CONSOLE

“When cold winter weather grips much of the country, take comfort with the warm thought that I am fishing my Canyon 366 off the Marquesas Keys.”

—MARK DOBLER, THE WOODLANDS, TX CANYON 366 OWNER

Beam Amidships: 13'2" (4.01 m)
 Bridge Clearance w/T-top: 9' (2.74 m)
 Center Line Length: 36'7" (11.15 m)
 Hull Draft: 29" (0.74 m)
 Maximum HP: 1050 (783 kW)
 Freshwater Capacity: 54 gal. (204.4 l)
 Weight w/o Engines: 12,850 lb. (5829 kg)

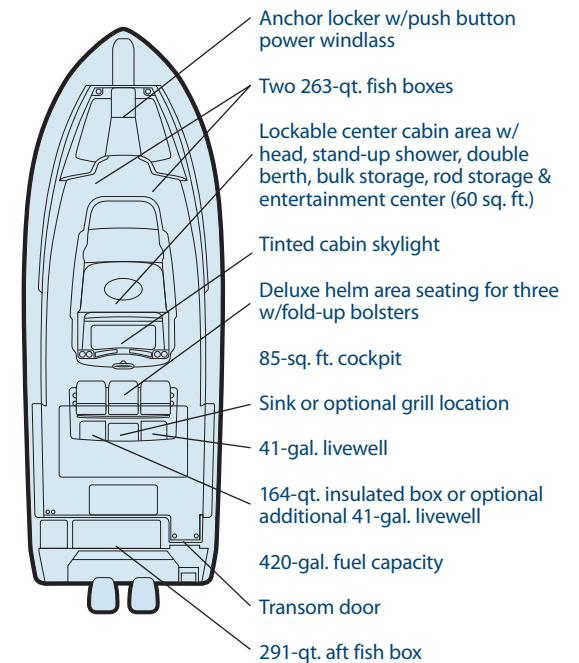

For detailed specifications see page 47.



Electromechanically operated electronics enclosure (enclosure up)



Console interior arrangement



Lean bar with 41-gal. (155.2 l) insulated raw water livewell with see-through lid, light, full column distribution inlet and overboard drain (110 GPH pump) (4164 LPH); lure holder and rigging station with freshwater sink, shown with optional second livewell; available standard with 164-qt. (155.2 l) cooler



Optional 1300 watt grill



Helm/lean bar seating with three deluxe sliding chairs with flip-up bolsters



Berth cushion with electrically adjustable bolster



Factory options add to more Grady Life fun!



▲ Hardtop front and side curtains for models 20' and up (330 shown). Drop curtain is available. Frames style and canvas vary per model.



▲ Cabin model hardtop with lockable radio box(es), spreader light(s), side rod holders and overhead storage net (optional models 22'-25', standard 29'-36')



▲ Freedom Series hardtop (255, 275, 307)



▲ Ivory canvas option for 225 soft top arch, hardtops, T-tops (255, 275, 283, 290, 300, 305, 306, 307, 330, 336, 360, 366)



▲ Fisherman series Bimini top (180, 209, 230)



▲ Bow casting platform insert with cushions (209, 230, 257, 283, 306, 336, 366); sun platform insert with cushions (205, 225, 255, 275, 307)



▲ Walkaround series vista top and side curtains (208, 226/228, 232, 258)



▲ Bow thruster (290, 300, 305, 306, 307, 330, 336); standard on 360, 366



▲ Freedom series vista top and side curtains (205, 225, 255, 275, 307)



▲ Bow pulpit shown with anchor windlass option



▲ Cabin rod racks (holds 4)



▲ Raw water livewell (lean bar option; 209)

Individualize your new Grady-White to best suit the water activities that your family enjoys with quality factory options that complement your boating lifestyle. Not all options shown here. For more information on factory options available per model, ask your dealer or visit www.gradywhite.com.



▲ Deluxe I helm chair



▲ Deluxe II helm chair



▲ Deluxe III helm chair



▲ Platinum helm chair



▲ Companion bench seat (300 shown)



▲ Companion bench seat (208, 226)



▲ Optional deluxe lean bar w/backrest and flip-up bolster (209, 230, 257, 306)



▲ 366 motorized bow table. Manual bow and/or cockpit tables are available options (205, 225, 255, 257, 283, 306, 366; standard on 275, 307). Tables vary per model.



▲ Ski pylon (180, 192, 205, 225, 230, 255, 275, 307); placement varies



▲ Freedom series sleeper seat with storage (192, 205, 225, 255)



▲ Electric grill (255, 275, 307, 366)

Bow rail - 316 grade stainless steel
Cockpit toe rails
Companion grab rail
Fold down motorwell bulkhead
Nonskid fiberglass liner
Nonskid recessed walkaround
Self-bailing cockpit w/cockpit drains (4)
Stainless steel through-hull fittings

Cabin

Berth - forward vee berth
Forward hatch - low profile acrylic hatch w/screen
Lighting - cabin dome light
Lighting - reading light
Lockable door w/screen & companionway hatch
Rod storage holders (4)
Storage - portable head compartment
Storage - under berth compartments (3)
Windows - opening windows w/screens (2)

Cockpit & Deck

100% hand laid hull & deck
Accessory outlet - 12V (2)
Battery select switch w/extra battery
Cockpit lights - LED lighting
Compass
Deck hardware - 316 grade stainless steel through-bolted
Drink holders - stainless steel (6)
Factory engine pre-rigging
Fish box - 103-qt. (97.5 l) port insulated fish box w/ob drain
Fish box - 106-qt. (100.3 l) starboard insulated fish box w/ob drain
Footrests (helm & companion)
Fuel capacity - 82-gallon (310.4 l) tank
International lighting
Rod holders (4)
Rod storage racks - horizontal (6)
Rubrail - high density PVC w/stainless steel insert
Seating - aft seats (2)
Seating - helm & companion pedestal chairs
Seating - port & starboard fish box cushions
Spring line cleats
Steering - no-feedback mechanical
Steering wheel - 316 grade stainless steel
Stern eyes - heavy-duty 316 stainless steel
Storage - aft seat lift out boxes (2)
Storage - forward anchor locker w/rode storage
Storage - lockable electronics box
Storage - lockable storage under helm chair
Storage - tackle drawers under companion chair (2)
Storage nets
Windshield - tempered glass
Windshield wiper (starboard)

OPTIONAL FEATURES

Bow lifting ring
Bow pulpit
CE certification package
Cockpit bolsters
Cockpit freshwater shower (recessed) - 10-gallon (37.9 l)
Hardtop top-mounted rod holders
Hardtop w/radio box, spreader lights & side mounted rod holders (4) & outrigger plates
Head - portable
Head - portable w/deck pump out
Hydraulic trim tabs w/indicator & retractor
Livewell - 25-gallon (94.6 l) insulated raw water livewell
Painted hull

Seating - companion bench seat
Seating - foredeck cushions
Steering - hydraulic (required w/F200 & F250 engines)
Steering - hydraulic tilt
Swim platform w/ladder
Washdown - pressurized raw water w/hose

CANVAS OPTIONS

Drop curtain (hardtop or vista top)
Hardtop front & side curtains
Vista top w/boot
Vista top w/front & side curtains



Fisherman 209

20' Center Console

Beam Amidships: 8'1" (2.46 m)

Bridge Clearance: 6'4" (1.95 m)

w/T-top: 7'9" (2.36 m)

Center Line Length: 20'4" (6.20 m)

Cockpit Depth: 25" (0.64 m)

Cockpit Area: 58 sq. ft. (5.4 m²)

Hull Draft: 15" (0.38 m)

Maximum HP: 250 (187 kW)

Outboard Shaft Length: 25" (0.64 m)

Standard Fuel Capacity: 82 gal. (310 l)

Transom Width: 7'10" (2.39 m)

Weight w/o Engine: 2600 lb. (1179 kg)

STANDARD FEATURES

Safety

Automatic bilge pump (1100 GPH) (4164 LPH)
Basic flotation
Bow rail - low profile 316 grade stainless steel
Cockpit toe rails
Console grab rail
Fold down motorwell bulkhead
Nonskid fiberglass liner
Self-bailing cockpit w/cockpit drains (2)
Stainless steel through-hull fittings

Cockpit & Deck

100% hand laid hull & deck
Battery select switch w/extra battery
Cockpit lights - LED lighting
Deck hardware - 316 grade stainless steel through-bolted
Drink holders - stainless steel (6)
Factory engine pre-rigging

Fish box - 88-qt. (83.28 l) port insulated fish box w/ob drain
Fish box - 88-qt. (83.28 l) starboard insulated fish box w/ob drain
Fuel capacity - 82-gallon (310.4 l) tank
International lighting
Rod holders (4)
Rod storage racks - horizontal (6)
Rubrail - high density PVC w/stainless steel insert
Seating - aft seats (2)
Seating - helm & companion pedestal chairs
Spring line cleats
Stern eyes - heavy-duty 316 stainless steel
Storage - aft rigging compartments (2)
Storage - forward anchor locker w/rode storage

Console

Accessory outlet - 12V (2)
Compass
Drink holders - stainless steel (2)
Head-lockable compartment w/head area & dome light
Rod storage holders - vertical (6)
Seating - removable cooler seat forward
Steering - no-feedback mechanical
Steering wheel - 316 grade stainless steel
Windshield - scratch resistant acrylic windshield w/handrail

OPTIONAL FEATURES

Bow lifting ring
CE certification package
Cockpit bolsters
Cockpit freshwater shower (recessed) - 10-gallon (37.9 l)
Forward bolsters
Head - portable
Head - portable w/deck pump-out
Head - portable w/in-line macerator
High bow rail
Hydraulic trim tabs w/indicator & retractor
Livewell (lean bar option only) - 23-gallon (87.1 l) insulated raw water livewell w/cushion
Painted hull
Painted lean bar rod holders (requires lean bar option)
Painted T-top frame (requires T-top option)
Seating - casting platform insert w/cushion
Seating - Deluxe lean bar w/backrest, flip-up bolster, fire extinguisher holder, footrest, tackle trays, lockable storage & rod holders (4)
Seating - port & starboard fish box cushions
Sirius satellite radio system
Steering - hydraulic (required w/F200 & F250 engines)
Steering - hydraulic tilt
Stereo w/MP3/auxiliary audio connections & fold down storage-satellite ready; speakers - bow (2), helm (2)
Swim platform w/ladder
T-top w/radio box, dome light, storage net, spreader light, rod holders (4), radar flat & outrigger plates
Washdown - pressurized raw water w/hose

CANVAS OPTIONS

Bimini top w/boot
T-top front & side curtains



Freedom 225

22' Dual Console

Beam Amidships: 8' (2.44 m)

Bridge Clearance: 5'6" (1.68 m)

Center Line Length: 22'2" (6.76 m)

Cockpit Depth: 25" (0.64 m)

Cockpit Area: 49 sq. ft. (4.6 m²)

Hull Draft: 16" (0.41 m)

Maximum HP: 300 (224 kW)

Outboard Shaft Length: 25" (0.64 m)

Standard Fuel Capacity: 96 gal. (363 l)

Transom Width: 7'11" (2.41 m)

Weight w/o Engine: 3450 lb. (1565 kg)

STANDARD FEATURES

Safety

Automatic bilge pump (1500 GPH) (5678 LPH)
Basic flotation
Bow rail - low profile 316 grade stainless steel
Cockpit toe rails
Companion grab rail
Fire extinguisher holder
Nonskid fiberglass liner
Self-bailing cockpit w/cockpit drains (2)
Stainless steel through-hull fittings

Cockpit & Deck

100% hand laid hull & deck
Accessory outlet - 12V (2)
Battery select switch w/extra battery
Cockpit freshwater shower (recessed)
Cockpit lights - LED lighting
Compass
Deck hardware - 316 grade stainless steel through-bolted
Drink holders - stainless steel (12)
Factory engine pre-rigging
Fish box - 175-qt. (165.6 l) aft insulated fish box w/ob drain
Fish box - 52-qt. (49.2 l) starboard bow insulated fish box w/ob drain
Footrest (helm)
Forward bolsters
Fuel capacity - 96-gallon (363.4 l) tank
Head - lockable console head area w/dome light & storage nets
Head - portable
Hydraulic trim tabs w/indicator & retractor
International lighting
Rod holders (4)
Rod storage racks - horizontal (6)
Rubrail - high density PVC w/stainless steel insert
Seating - Deluxe II vertically & horizontally adjustable helm & companion chairs
Seating - fold away aft bench seat w/cushion

Seating - port & starboard bow box cushions
Spring line cleats
Steering - hydraulic tilt
Steering wheel - 316 grade stainless steel
Stern eyes - heavy-duty 316 stainless steel
Storage - 22-gallon (83.3 l) insulated aft storage compartment
Storage - forward anchor locker w/rode storage
Storage - forward bow seat compartment
Storage - lockable console storage compartment w/service light
Storage - lockable console tackle drawers
Storage - port bow seat compartment
Swim platform - full transom width w/ladder
Water tank - 10-gallon (37.9 l) freshwater
Windshield - walk-through tempered glass windshield
Windshield wiper (starboard)

OPTIONAL FEATURES

Bow lifting ring
CE certification package
Cockpit bolsters
Head - portable w/deck pump out
Head - portable w/in-line macerator
Livewell - 22-gallon (83.3 l) aft insulated raw water livewell w/light, full column distribution inlet & ob drain (1100 GPH pump) (4164 LPH)
Painted hull
Seating - port sleeper seat w/storage drawer
Sirius satellite radio system
Ski pylon
Soft top arch w/canvas
Stereo w/MP3/auxiliary audio connections & fold down storage - satellite ready; speakers - bow (2) & helm (2)
Sun platform insert w/cushion
Table (bow)
Washdown - pressurized raw water w/hose

CANVAS OPTIONS

(Available in ivory or navy)
Bow cover
Sleeper seat cover
Soft top arch (ivory)
Tonneau cover
Vista top w/boot
Vista top aft curtain
Vista top drop curtain
Vista top front & side curtains

Cutting board
Deck hardware - 316 grade stainless steel through-bolted
Drink holders - stainless steel (9)
Factory engine pre-rigging
Fish box - 265-qt. (250.8 l) starboard insulated fish box w/ob drain
Fish box - 297-qt. (281.1 l) aft insulated fish box w/ob drain
Flush mount electronics kit
Footrests - helm & companion (adjustable)
Fuel capacity - 150-gallon (567.8 l) tank
Hydraulic trim tabs w/indicator & retractor
International lighting
Livewell - 36-gallon (136.3 l) port insulated raw water livewell w/light, full column distribution inlet & ob drain (1100 GPH pump) (4164 LPH)

Rod holders (4)
Rod storage racks - horizontal (6)
Rubrail - high density PVC w/stainless steel insert
Seating - Deluxe I helm & companion chairs
Seating - fold away aft bench seat w/cushion
Seating - port livewell cushion
Seating - starboard fish box cushion
Spring line cleats
Steering - hydraulic tilt
Steering wheel - 316 grade stainless steel
Stern eyes - heavy-duty 316 stainless steel
Storage - forward anchor locker w/rode storage
Storage - tackle drawers under companion seat (2)
Storage - tackle trays under helm chair (2)
Swim platform - full transom width w/ladder
Washdown - pressurized raw water w/hose
Water tank - 12-gallon (45.4 l) freshwater
Windshield - ventilated tempered glass windshield
Windshield wipers

OPTIONAL FEATURES

Air conditioner
Anchor windlass (must have bow pulpit)
Bow lifting ring
Bow pulpit
CE certification package
Cockpit bolsters
Cushions - auxiliary berth cushions
Hardtop top-mounted rod holders
Hardtop w/radio box, storage net, spreader lights, side mounted rod holders (4) & outrigger plates
Head - marine head w/electric flush & 10-gallon (37.9 l) holding tank
Head - marine head w/macerator, 10-gallon (37.9 l) holding tank & pump out
Head - portable
Head - portable w/deck pump out
Head - portable w/in-line macerator
Outrigger kit - 15-ft. (4.6 m) radial hardtop mounted (hardtop option only)
Painted hull
Rod storage - folding cabin rack (4)
Seating - Deluxe II helm and companion chairs
Seating - foredeck cushions
Sirius satellite radio system
Stereo system w/MP3/auxiliary audio connections/amplifier & fold down storage - satellite ready; speakers - cabin (2), cockpit (2) & helm (2)
Storage - lockable electronics box
Windshield washer - freshwater (starboard)

CANVAS OPTIONS

Hardtop drop curtain
Hardtop front & side curtains



Freedom 255

25' Dual Console

Beam Amidships: 8'6" (2.59 m)

Bridge Clearance: 5'7" (1.70 m)

w/Hardtop: 7'8" (2.34 m)

Center Line Length: 24'9" (7.55 m)

Cockpit Depth: 27" (.69 m)

Cockpit Area: 60 sq. ft. (5.6 m²)

Hull Draft: 20" (.51 m)

Maximum HP: 350 (261 kW)

Outboard Shaft Length

Single: 30" (.76 m)

Dual: 25" (.64 m)

Standard Fuel Capacity: 153 gal. (579 l)

Transom Width: 7'10" (2.39 m)

Weight w/o Engine: 4459 lb. (2023 kg)

STANDARD FEATURES

Safety

2 automatic bilge pumps (2600 GPH)
Basic flotation
Bow rail - low profile 316 grade stainless steel
Cockpit toe rails
Nonskid fiberglass liner
Self-bailing cockpit w/cockpit drains (4)
Stainless steel through-hull fittings

Cockpit & Deck

100% hand laid hull & deck
Accessory outlet - 12V (2)
Anchor windlass wiring
Battery select switch(es) w/extra battery
Cockpit bolsters
Cockpit freshwater shower (recessed)
Cockpit lights - LED lighting
Companion grab rail
Compass
Cutting board
Deck hardware - 316 grade stainless steel through-bolted
Drink holders - stainless steel (9)
Factory engine pre-rigging
Fish box - 165-qt. (156.1 l) starboard insulated fish box w/ob drain
Footrest - helm
Forward bolsters
Fuel capacity - 153-gallon (579 l) tank
Head - lockable console w/dome light & bulk storage
Head - portable
Hydraulic trim tabs w/indicator & retractor
Integrated outboard mounting system w/swim platform & ladder
International lighting
Rod holders (6)
Rod storage racks - horizontal (6)
Rubrail - high density PVC w/stainless steel insert

Seating - fold away aft bench seat w/cushion
Seating - port & starboard bow box cushions
Seating - vertically & horizontally adjustable deluxe helm & companion chairs
Spring line cleats
Steering - hydraulic tilt
Steering wheel - 316 grade stainless steel
Stern eyes - heavy-duty 316 stainless steel
Storage - 80-qt. (75.7 l) port bow storage box
Storage - 104-qt. (98.4 l) port aft box
Storage - forward anchor locker w/rode storage
Storage - starboard lockable storage area
Transom door - fiberglass
Water tank - 20-gallon freshwater
Windshield - walk-through tempered glass windshield
Windshield wiper (starboard)

OPTIONAL FEATURES

Anchor windlass
Bow lifting ring
Bow table
Grill - electric (replaces sink in wet bar option)
Hardtop top mounted rod holders (requires hardtop option)
Hardtop speakers (2) in lieu of helm speakers (requires hardtop, stereo options)
Hardtop w/spreader lights, storage net & outrigger plates
Head - marine head w/electric flush (10-gallon)(37.9 l)
Head - marine head w/macerator, 10-gallon (37.9 l) holding tank & pump out
Head - portable w/deck pump out
Head - portable w/in-line macerator
International AC electrical conversion - 220V (50Hz)
Livewell - 26-gallon (98.4 l) aft insulated raw water livewell w/light, full column distribution inlet & ob drain (1100 GPH pump) (4164 LPH)
Outrigger kit - 15-ft. (4.6 m) radial hardtop mounted (hardtop option only)
Painted hull
Seating - Deluxe II helm chair (starboard)
Seating - Deluxe II helm & companion chairs
Seating - Deluxe III helm chair (starboard)
Seating - sleeper seat w/ storage drawer
Sirius satellite radio system
Ski pylon
Stereo w/MP3/auxiliary audio connections/amplifier & fold down storage - satellite ready; speakers - aft (2), bow (2) & helm (2)
Sun platform insert w/cushion
Washdown - pressurized raw water w/hose
Wet bar w/electronically-operated helm lounge seat, sink, storage drawer & trash compartment

CANVAS OPTIONS

(Available in ivory or navy)
Aft curtain (hardtop and vista top)
Bow cover
Drop curtain (hardtop and vista top)
Hardtop front & side curtains
Sleeper seat cover
Tonneau cover
Vista top w/boot
Vista top front & side curtains



Fisherman 257

25' Center Console

Beam Amidships: 8'6" (2.59 m)

Bridge Clearance: 7' (2.13 m)

w/T-top: 8'6" (2.59 m)

Center Line Length: 24'9" (7.55 m)

Cockpit Depth: 27" (0.69 m)

Cockpit Area: 64 sq. ft. (5.9 m²)

Hull Draft: 20" (0.51 m)

Maximum HP: 350 (261 kW)

Outboard Shaft Length:

Single: 30" (0.76 m)

Dual: 25" (0.64 m)

Standard Fuel Capacity: 151 gal. (572 l)

Transom Width: 7'10" (2.39 m)

Weight w/o Engine: 4045 lb. (1835 kg)

STANDARD FEATURES

Safety

2 automatic bilge pump (2600 GPH) (9842 LPH)
Basic flotation
Bow rail - low profile 316 grade stainless steel
Cockpit toe rails
Console grab rail
Fire extinguisher holder
Nonskid fiberglass liner
Self-bailing cockpit w/cockpit drains (4)
Stainless steel through-hull fittings

Cockpit & Deck

100% hand laid hull & deck
Battery select switch(es) w/extra battery
Cockpit bolsters
Cockpit freshwater shower (recessed)
Cockpit lights - LED lighting
Compass
Cutting board
Deck hardware - 316 grade stainless steel through-bolted
Drink holders - stainless steel (3)
Factory engine pre-rigging
Fish box - 120-qt. (113.6 l) forward divided port insulated fish box w/ob drain
Fish box - 120-qt. (113.6 l) forward starboard insulated fish box w/ob drain
Fish box - 185-qt. (175.1 l) aft insulated fish box w/ob drain
Forward bolsters
Fuel capacity - 151-gallon (571.6 l) tank
Hydraulic trim tabs w/indicator & retractor
Integrated outboard mounting system w/swim platform & ladder
International lighting

Livewell - 32-gallon (121.1 l) aft insulated raw water livewell w/light, full column distribution inlet & ob drain (1100 GPH pump) (4164 LPH)
Rod holders (4)
Rod storage racks - horizontal (6)
Rubrail - high density PVC w/stainless steel insert
Seating - deluxe lean bar w/footrest, backrest, flip-up bolster, knife & pliers holders, tackle trays, lockable storage & rod holders (4)
Seating - fold away aft bench seat w/cushion
Seating - port & starboard fish box cushions
Spring line cleats
Stern eyes - heavy-duty 316 stainless steel
Storage - forward anchor locker w/rode storage
Transom door - fiberglass
Washdown - pressurized raw water w/hose
Water tank - 20-gallon (75.7 l) freshwater

Console

Accessory outlet - 12V (2)
Console ventilator
Drink holders - stainless steel (2)
Head - lockable console w/stand up head area, dome light, storage shelves & hanging locker
Seating - molded forward console seat w/cushion
Steering - hydraulic tilt
Steering wheel - 316 grade stainless steel
Storage - under footrest
Storage nets
Windshield - scratch resistant acrylic windshield w/handrail

OPTIONAL FEATURES

Anchor windlass w/bow roller
Anchor windlass w/ bow pulpit
Bow lifting ring
Bow pulpit (includes high profile bow rail)
Casting platform insert w/cushions
CE certification package
Head - portable
Head - portable w/deck pump out
Head - portable w/in-line macerator
Outrigger kit - 15-ft. (4.6 m) radial T-top mounted
Painted hull
Painted lean bar rod holders
Painted T-top frame (requires T-top option)
Sirius satellite radio system
Stereo system w/MP3/auxiliary audio connections & fold down storage - satellite ready; speakers - console forward (2) & helm (2)
T-top w/radio box, radar flat, dome light, storage net, spreader light, rod holders (4) & outrigger plates
Table (bow)

CANVAS OPTIONS

T-top front & side curtains

Seating - Deluxe I vertically & horizontally adjustable helm & companion chairs
 Seating - fold away aft bench seat w/cushion
 Seating - port & starboard bow box cushions
 Spring line cleats
 Steering - hydraulic tilt
 Steering wheel - 316 grade stainless steel
 Stereo system w/MP3/auxiliary audio connections/amplifier & fold down storage - satellite ready; speakers - aft (2), bow (2) & helm (2)
 Stern eyes - heavy-duty 316 stainless steel
 Storage - 128-quart (121.1 l) aft insulated box
 Storage - forward anchor locker w/rode storage
 Storage - port bow box
 Storage - starboard console storage drawer
 Storage - starboard lockable storage w/service light
 Table (bow) (doubles in cockpit area)
 Transom door - fiberglass
 Washdown - pressurized raw water w/hose
 Water tank - 20-gallon (75.7 l) freshwater
 Windshield - walk-through tempered glass windshield
 Windshield wiper (starboard)

OPTIONAL FEATURES

Anchor windlass w/bow roller
 Bow lifting ring
 CE certification package
 Deluxe bar w/grill, electromechanically operated helm seat, fire extinguisher holder, storage drawer & trash compartment
 Hardtop w/radio box, storage net, spreader lights & outrigger plates
 Hardtop top-mounted rod holders
 Head - marine head w/electric flush (10-gallon) (37.9 l)
 Head - marine head w/macerator, 10-gallon (37.9 l) holding tank & pump out
 Head - portable w/deck pump out
 Head - portable w/in-line macerator
 International AC electrical conversion 220V (50Hz)
 Livewell - 32-gallon (121.1 l) aft insulated raw water livewell w/light, full column distribution inlet & ob drain (1100 GPH pump) (4164 LPH)
 Outrigger kit - 15-ft. (4.6 m) radial hardtop mounted (hardtop option only)
 Painted hull
 Seating - Deluxe II helm chair (starboard)
 Seating - Deluxe II helm & companion chairs
 Seating - Deluxe III helm chair (starboard)
 Seating - electric extendable port lounge seat
 Sirius satellite radio system
 Ski pylon
 Sun platform insert w/cushion
 Wet bar w/electronically-operated helm seat, fire extinguisher holder, sink, storage drawer & trash compartment

CANVAS OPTIONS

(Available in ivory or navy)
 Aft curtain (hardtop or vista top)
 Bow cover
 Drop curtain (hardtop or vista top)
 Hardtop front & side curtains
 Lounge seat cover
 Tonneau cover
 Vista top w/boot
 Vista top front & side curtains
 Wet bar cover



Canyon 283

28' Center Console

Beam Amidships: 9'6" (2.90 m)
 Bridge Clearance: 7'7" (2.31 m)
 w/T-top: 9' (2.74 m)
 Center Line Length: 28' (8.53 m)
 Cockpit Depth: 27" (0.69 m)
 Cockpit Area: 69 sq. ft. (6.4 m²)
 Hull Draft: 20" (0.51 m)
 Maximum HP: 600 (448 kW)
 w/V6 engines only
 Outboard Shaft Length: 25" (0.64 m)
 Standard Fuel Capacity: 205 gal. (776 l)
 Transom Width: 9' (2.74 m)
 Weight w/o Engines: 5864 lb. (2660 kg)

STANDARD FEATURES

Safety
 2 automatic bilge pumps (total 2600 GPH) (9842 LPH)
 Basic flotation
 Bow rail - low profile 316 grade stainless steel
 Cockpit toe rails
 Console grab rail
 Fire extinguisher holder
 Nonskid fiberglass liner
 Self-bailing cockpit w/cockpit drains (4)
 Stainless steel through-hull fittings

Cockpit & Deck

100% hand laid hull & deck
 Anchor windlass wiring
 Battery select switches w/extra battery
 Cockpit bolsters
 Cockpit lights - LED lighting
 Cutting board
 Deck hardware - 316 grade stainless steel through-bolted
 Drink holders - stainless steel (7)
 Factory engine pre-rigging
 Fish box - 265-qt. (250.8 l) aft insulated fish box w/ob drain & removable partition
 Fish box - 135-qt. (127.8 l) port & starboard forward insulated fish boxes w/ob drain
 Forward bolsters
 Fuel capacity - 205-gallon (776 l) tank
 Hydraulic trim tabs w/indicator & retractor
 Integrated outboard mounting system w/swim platform & ladder
 International lighting
 Rod holders (4)
 Rod storage racks - lockable horizontal (6) (up to 9')(2.7 m)
 Rubrail - high density PVC w/stainless steel insert
 Seating - fold away aft bench seat w/cushion
 Seating - port & starboard fish box cushions

Spring line cleats
 Stern eyes - heavy-duty 316 stainless steel
 Storage - aft deck lift out box (also fits in forward port fish box)
 Storage - forward anchor locker w/rode storage
 Transducer mounting flats
 Transom door - fiberglass
 Washdown - pressurized raw water w/hose
 Water tank - 20-gallon (75.7 l) freshwater

Console

Accessory outlet - 12V (2)
 Compass
 Console ventilator
 Drink holders - stainless steel (2)
 Head - lockable console w/stand up head area, bulk storage & drawers, dome light, shower, sink, marine head w/macerator (10-gallon) (37.9 l) & pump out
 Seating - molded forward console seat w/cushion
 Steering - hydraulic tilt
 Steering wheel - 316 grade stainless steel
 Storage - electromechanically operated electronics enclosure
 Storage - under footrest
 Windshield - tempered glass windshield
 Windshield washer - freshwater
 Windshield wiper

Deluxe Lean Bar

Backrest
 Bait rigging locker
 Footrest
 Knife, pliers & rig holders (2)
 Livewell - 45-gallon (170.3 l) insulated raw water livewell w/light, full column distribution inlet & ob drain (1100 GPH pump) (4164 LPH)
 Rod holders (4)
 Sink w/pullout freshwater faucet
 Storage - lockable tackle drawer
 Storage - lockable tackle locker w/tackle trays
 Storage - port net storage area

OPTIONAL FEATURES

Anchor windlass w/ bow pulpit
 Anchor windlass w/ bow roller
 Bow lifting ring
 Bow pulpit (includes high profile bow rail)
 Casting platform insert w/cushions
 CE certification package
 Convenience package - battery charger & dockside power
 Head - marine head w/electric flush (10-gallon) (37.9 l)
 Outrigger kit - 15-ft. (4.6 m) radial T-top mounted (w/T-top option only)
 Painted hull
 Painted lean bar rod holders
 Painted T-top frame (requires T-top option)
 Sirius satellite radio system
 Steering - power assist (standard w/TF300 package)
 Stereo system w/MP3/auxiliary audio connections/amplifier & fold down storage - satellite ready; speakers - console forward (2) & helm (2)
 T-top (fiberglass) w/radio box, dome light, storage net, spreader light, rod holders (4) & outrigger plates
 T-top speakers (2) (requires stereo and T-top options)
 Table (bow)

CANVAS OPTIONS

(Available in ivory or navy)
 T-top front & side curtains



Chesapeake 290

29' Walkaround Cabin

Beam Amidships: 9'11" (3.02 m)
 Bridge Clearance w/Hardtop: 9'9" (2.97 m)
 Center Line Length: 28'6" (8.69 m)
 Cockpit Depth: 28" (0.71 m)
 Cockpit Area: 56 sq. ft. (5.2 m²)
 Hull Draft: 24" (0.6 m)
 Length Overall (w/bow roller): 29'9" (9.07 m)
 Maximum HP: 600 hp (448 kW)
 Outboard Shaft Length: 25" (0.64 m)
 Standard Fuel Capacity: 206 gal. (780 l)
 Transom Width: 9'1" (2.76 m)
 Weight w/o Engines: 7650 lb. (3470 kg)

STANDARD FEATURES

Safety
 2 automatic bilge pumps (total 2600 GPH) (9842 LPH)
 Basic flotation
 Bow rail - 316 grade stainless steel
 Cockpit toe rails
 Companion grab rail
 Nonskid fiberglass liner
 Nonskid recessed walkaround
 Self-bailing cockpit w/cockpit drains (6)
 Stainless steel through-hull fittings

Cabin

Accessory outlet - 12V
 Berth - aft double berth
 Berth - forward vee berth
 Cabin lights (6)
 Cabin window curtains
 Forward hatch - low profile acrylic hatch w/screen
 Galley - port side galley w/sink, Corian® countertop
 Head - enclosed head area w/sink, shower, lamp & marine head w/macerator, 10-gallon (37.9 l) holding tank & pump out
 Lighting - dome lights (6)
 Lockable door w/screen & companionway hatch
 Microwave oven
 Mirror
 Refrigerator
 Storage - galley shelves
 Storage nets
 Stove - electric glass top
 Table - cherry
 Teak & holly sole
 Water heater - 6 gallon (22.7 l), 120V
 Water tank - 32-gallon (121.1 l) freshwater
 Windows - opening windows w/screens (2)

Cockpit & Deck

100% hand laid hull & deck
 Accessory outlet - 12V (2)

Anchor windlass wiring
 Battery charger system
 Battery select switches w/extra battery
 Cockpit bolsters
 Cockpit lights - LED lighting
 Cockpit shower - freshwater (recessed)
 Compass
 Cutting board
 Deck hardware - 316 grade stainless steel through-bolted
 Dockside power w/galvanic isolator
 Drink holders - stainless steel (11)
 Factory engine pre-rigging
 Fish box - 132-qt. (124.9 l) starboard insulated fish box w/ob drain
 Fish box - 265-qt. (250.8 l) aft insulated fish box w/ob drain
 Footrests - helm & companion (adjustable)
 Fuel capacity - 206-gallon (779.8 l) tank
 Hardtop w/radio box, storage nets, spreader lights, rod holders (4), outrigger plates & canvas (canvas available in navy or ivory)
 Hydraulic trim tabs w/indicator & retractor
 Integrated outboard mounting system w/swim platform & ladder
 International lighting
 Livewell - 35-gallon (132.5 l) port insulated raw water livewell w/light, full column distribution inlet & ob drain (1100 GPH pump) (4164 LPH)
 Rod holders (4)
 Rod storage racks - horizontal (6)
 Rubrail - high density PVC w/stainless steel insert
 Seating - Deluxe II horizontally adjustable helm & companion chairs
 Seating - fold away aft bench seat w/cushion
 Seating - port livewell cushion
 Seating - starboard fish box cushion
 Spring line cleats
 Steering - hydraulic tilt
 Steering wheel - 316 grade stainless steel
 Stern eyes - heavy-duty 316 stainless steel
 Storage - aft box
 Storage - forward anchor locker w/rode storage
 Storage - lockable storage under helm seat
 Storage - tackle drawers under companion seat (2)
 Transducer mounting flats
 Transom door - fiberglass
 Washdown - pressurized raw water w/hose
 Windshield - ventilated tempered glass windshield
 Windshield washer - freshwater (starboard)
 Windshield wipers

OPTIONAL FEATURES

Air conditioning - 8000 BTU
 Anchor windlass w/bow roller
 Bow thruster
 CE Certification package
 Cockpit shower w/hot water
 Flat screen TV/DVD player
 Generator - 4kW diesel, 12-gallon (45.4 l) fuel capacity
 Hardtop top-mounted rod holders (5)
 Head - marine head w/electric flush (10-gallon) (37.9 l)
 International AC electrical conversion - 220V 50Hz
 Outrigger kit - 15-ft. (4.6 m) radial hardtop mounted
 Painted hull
 Seating - companion bench seat
 Seating - Deluxe III helm chair w/flip-up bolster
 Seating - Deluxe III helm and companion chairs w/flip-up bolsters
 Sirius satellite radio system
 Steering - power assist (standard w/TF300 pkg)
 Stereo system w/MP3/auxiliary audio connections/amplifier & fold down storage - satellite ready; speakers - cabin (2), helm (2) & hardtop (2)



Marlin 300

30' Walkaround Cabin

Beam Amidships: 10'7" (3.23 m)

Bridge Clearance w/Hardtop: 9'9" (2.97 m)

Center Line Length: 30'6" (9.30 m)

Cockpit Depth: 29" (0.74 m)

Cockpit Area: 74 sq. ft. (6.9 m²)

Hull Draft: 23" (0.58 m)

Length Overall (w/pulpit): 32'7" (9.93 m)

Maximum HP: 700 (522 kW)

Outboard Shaft Length: 25" (0.64 m)

Standard Fuel Capacity: 300 gal. (1136 l)

Transom Width: 9'6" (2.90 m)

Weight w/o Engines: 8221 lb. (3729 kg)

STANDARD FEATURES

Safety

2 automatic bilge pumps (total 2600 GPH) (9842 LPH)
Basic flotation
Bow rail - 316 grade stainless steel
Cockpit toe rails
Companion grab rail
Nonskid fiberglass liner
Nonskid recessed walkaround
Self-bailing cockpit w/cockpit drains (4)
Stainless steel through-hull fittings

Cabin

Accessory outlet - 12V
Berth - aft double berth
Berth - forward vee berth
Cabin window curtains
Forward hatch - low profile acrylic hatch w/screen & shade
Galley - port side galley w/sink & Corian® cutting board
Head - enclosed head area w/sink, shower, lamp & VacuFlush® marine head w/10-gallon (37.9 l) holding tank & pump out
Lighting - dome lights (2)
Lighting - reading lights (3)
Lockable door w/screen & companionway hatch
Microwave oven
Mirror
Refrigerator
Rod storage - aft berth
Rod storage racks (6)
Stereo system w/MP3/auxiliary audio connections/ amplifier & fold down storage - satellite ready; speakers - cabin (2), cockpit (2) & helm (2)
Storage - galley cabinet & counter
Storage - under berth compartments
Storage nets
Stove - electric glass top
Table - cherry

Teak & holly sole
Water heater - 6-gallon (22.7 l), 120V
Water tank - 32-gallon (121.1 l) freshwater
Window - aft berth window w/screen
Windows - tinted frameless acrylic (2)

Cockpit & Deck

100% hand laid hull & deck
Accessory outlet - 12V (2)
Anchor windlass w/remote switches at helm & windlass
Batteries (4)
Battery charger system
Battery select switches w/extra battery
Bow pulpit w/roller
Cockpit bolsters
Cockpit freshwater shower (recessed)
Cockpit lights - LED lighting
Compass
Deck hardware - 316 grade stainless steel through-bolted
Dockside power w/galvanic isolator
Drink holders - stainless steel (9)
Factory engine pre-rigging
Fighting chair reinforcement
Fish box - 290-qt. (274.4 l) aft insulated fish box w/ob drain
Flush mount electronics kit
Footrests - helm & companion (adjustable)
Freshwater level indicator
Fuel capacity - 300 gallons (150-gallon tank, 150-gallon tank) (1135 l)
Hardtop w/radio box, storage nets, spreader lights, rod holders (4), outrigger plates & canvas (canvas available in navy or ivory)
Hydraulic trim tabs w/indicator & retractor
Integrated outboard mounting system w/swim platform & ladder
International lighting
Livewell - 32-gallon (121.1 l) port insulated raw water livewell w/light, full column distribution inlet & ob drain (1100 GPH pump) (4164 LPH)
Rigging station behind helm chair w/freshwater sink, insulated bait box w/ob drain & lockable drawers
Rod holders (4)
Rod storage racks - horizontal (6)
Rubrail - high density PVC w/stainless steel insert
Seating - Deluxe II vertically & horizontally adjustable helm & companion chairs
Seating - fold away aft bench seat w/cushion
Seating - foredeck cushions
Seating - port livewell cushion
Seating - starboard tackle station cushion
Spring line cleats
Steering - hydraulic tilt
Steering wheel - 316 grade stainless steel
Stern eyes - heavy-duty 316 stainless steel
Storage - aft deck lift out box
Storage - forward anchor locker w/rode storage
Storage - lockable electronics box
Storage - lockable storage under helm & companion seats
Storage - under step compartment
Transducer mounting flats
Transom door - fiberglass
Washdown - freshwater
Washdown - pressurized raw water w/hose
Windshield - ventilated tempered glass windshield
Windshield washer - freshwater (starboard)
Windshield wipers

OPTIONAL FEATURES

Air conditioning - 7000 BTU
Bow thruster
CE certification package
Cockpit shower w/hot water
Flat screen TV w/DVD player & audio visual inputs
Generator - 4kW diesel, 12-gallon (45.4 l) fuel capacity
Hardtop top-mounted rod holders (5)
International AC electrical conversion - 220V 50Hz
Lighting - underwater LED (2)
Outrigger kit - 15-ft. (4.6 m) radial hardtop mounted
Outrigger kit - 24-ft. (7.3 m) Lee Pro Series (lay out)
Painted hull
Rod storage - folding cabin rack (4)
Seating - companion bench seat
Seating - Deluxe III helm and companion chairs w/flip-up bolsters
Sirius satellite radio system
Steering - power assist (standard w/TF300 & TF350 pkgs)
Storage - lockable electronics box



Express 305

30' Express Cabin

Beam Amidships: 10'7" (3.23 m)

Bridge Clearance w/Hardtop: 9'9" (2.97 m)

Center Line Length: 30'6" (9.30 m)

Cockpit Depth: 28" (0.71 m)

Cockpit Area: 63 sq. ft. (5.9 m²)

Hull Draft: 23" (0.58 m)

Length Overall (w/pulpit): 32'7" (9.93 m)

Maximum HP: 700 (522 kW)

Outboard Shaft Length: 25" (0.64 m)

Standard Fuel Capacity: 290 gal. (1098 l)

Transom Width: 9'6" (2.90 m)

Weight w/o Engines: 8850 lb. (4014 kg)

STANDARD FEATURES

Safety

2 automatic bilge pumps (total 2600 GPH) (9842 LPH)
Basic flotation
Bow rail - 316 grade stainless steel
Cockpit toe rails
Companion grab rail
Fire extinguisher holder
Nonskid fiberglass liner
Self-bailing cockpit w/cockpit drains (6)
Stainless steel through-hull fittings

Cabin

Accessory outlet - 12V
Berth - aft double berth
Berth - forward vee berth
Forward hatch - low profile acrylic hatch w/screen & shade
Galley - port side galley w/sink, Corian® cutting board & light
Head - enclosed head area w/stainless steel sink, shower, lamp & VacuFlush® marine head w/10-gallon (37.9 l) holding tank & pump out
Lighting - dome lights (4)
Lighting - recessed (3)
Lighting - reading (2)
Lockable door w/screen & companionway hatch
Microwave oven
Mirror
Refrigerator
Rod storage - aft berth
Stereo system w/MP3/auxiliary audio connections/amplifier & fold down storage - satellite ready; speakers - cabin (2) & cockpit (2)

Storage - galley cabinet & counter
Storage - under berth compartments
Storage nets
Stove - electric glass top
Table - cherry
Teak & holly sole
Water heater - 6-gallon (22.7 l), 120V
Water tank - 32-gallon (121.1 l) freshwater

Cockpit & Deck

100% hand laid hull & deck
Accessory outlet - 12V (2)
Anchor windlass w/remote switches at helm & windlass
Batteries (4)
Battery charger system
Battery select switches w/extra batteries
Bow pulpit w/roller
Cockpit bolsters
Cockpit freshwater shower (recessed) (2)
Cockpit lights - LED lighting
Compass
Cooler - 73-qt. (69.1 l) port insulated cooler w/ob drain
Deck hardware - 316 grade stainless steel through-bolted
Dockside power w/galvanic isolator
Drink holders - stainless steel (14)
Factory engine pre-rigging
Fighting chair reinforcement
Fish box - 304-qt. (287.7 l) aft insulated fish box w/ob drain
Footrests - helm & companion (adjustable)
Freshwater level indicator
Fuel capacity - 290 gallons (151-gallon tank, 139-gallon tank) (1098 l)
Hardtop w/flush mount radio box, storage nets, spreader lights, speakers (2), rod holders (6), outrigger plates & canvas (canvas available in navy or ivory)
Hydraulic trim tabs w/indicator & retractor
Integrated outboard mounting system w/swim platform & ladder
International lighting
Livewell - 32-gallon (121.1 l) starboard insulated raw water livewell w/light, full column distribution inlet & ob drain (1100 GPH pump) (4164 LPH)
Rod holders (4)
Rod storage racks - horizontal (6)
Rubrail - high density PVC w/stainless steel insert
Seating - companion bench seat
Seating - Deluxe II vertically & horizontally adjustable helm chair
Seating - fold away aft bench seat w/cushion
Seating - port cooler cushion w/footrest
Spring line cleats
Steering - hydraulic tilt
Steering wheel - 316 grade stainless steel
Stern eyes - heavy-duty 316 stainless steel
Storage - electromechanically operated electronics enclosure
Storage - forward anchor locker w/rode storage
Storage - lockable storage under companion seat
Transducer mounting flats
Transom door - fiberglass
Washdown - freshwater
Washdown - pressurized raw water w/hose
Windshield - ventilated tempered glass windshield
Windshield washer - freshwater
Windshield wiper

OPTIONAL FEATURES

Air conditioning - 7000 BTU
Bow thruster
CE certification package
Cockpit shower w/hot water
Chill plates - refrigeration plates for fishbox/cooler w/digitally controlled thermostat
Flat screen 15" LCD TV w/DVD player & audio visual inputs
Generator - 4 kW diesel, 12-gallon (45.4 l) fuel capacity
Hardtop top-mounted rod holders (6)
International AC electrical conversion - 220V 50Hz
Lighting - underwater LED (2)
Painted hull
Outrigger kit - 15-ft. (4.6 m) radial hardtop mounted
Outrigger kit - 24-ft. (7.3 m) Lee Pro Series (lay out)
Seating - Deluxe III helm chair w/flip-up bolster
Sirius satellite radio system
Steering - power assist (standard w/TF300 & TF350 pkgs)



Canyon 306

30' Center Console

Beam Amidships: 10'7" (3.23 m)

Bridge Clearance: 7'3" (2.21 m)

w/T-top: 9'4" (2.84 m)

Center Line Length: 30'6" (9.30 m)

Cockpit Depth: 27" (0.69 m)

Cockpit Area: 75 sq. ft. (7.0 m²)

Hull Draft: 21" (0.53 m)

Maximum HP: 700 (522 kW)

Outboard Shaft Length: 25" (0.64 m)

Standard Fuel Capacity: 290 gal. (1098 l)

Transom Width: 9'6" (2.90 m)

Weight w/o Engines: 6950 lb. (3152 kg)

STANDARD FEATURES

Safety

2 automatic bilge pumps (total 2600 GPH) (9842 LPH)
Basic flotation
Bow rail - low profile 316 grade stainless steel
Cockpit toe rails
Console grab rail
Fire extinguisher holder
Nonskid fiberglass liner
Self-bailing cockpit w/cockpit drains (4)
Stainless steel through-hull fittings

Cockpit & Deck

100% hand laid hull & deck
Anchor windlass w/remote switches at helm & windlass
Battery select switches w/extra battery
Cleats - flushmount (pop up)
Cockpit bolsters
Cockpit freshwater shower (recessed)
Cockpit lights - LED lighting
Cutting board
Deck hardware - 316 grade stainless steel through-bolted
Drink holders - stainless steel (7)
Factory engine pre-rigging
Fish box - 150-qt. (287.7 l) port & starboard insulated fish boxes w/ob drain
Fish box - 304-qt. (287.7 l) aft insulated fish box w/ob drain
Forward bolsters
Fuel capacity - 290 gallons (150-gallon tank, 140-gallon tank) (1098 l)
Hydraulic trim tabs w/indicator & retractor
Integrated outboard mounting system w/swim platform & ladder
International lighting
Rod holders (6)
Rod storage racks - lockable horizontal (6)
Rubrail - high density PVC w/stainless steel insert
Seating - fold away aft bench seat w/cushion

Seating - port & starboard fish box cushions
Stern eyes - heavy-duty 316 stainless steel
Storage nets
Transducer mounting flats
Transom door - fiberglass
Washdown - freshwater
Washdown - pressurized raw water w/hose
Water tank - 32-gallon (121.1 l) freshwater

Console

Accessory outlet - 12V (2)
Compass
Console ventilator
Drink holders - stainless steel (2)
Head - lockable console w/stand up head area, dome light, shower, sink, bulk storage drawers, marine head w/macerator, 10-gallon (37.9 l) holding tank & pump out
Seating - molded forward console seat w/cushion
Steering - hydraulic tilt
Steering wheel - 316 grade stainless steel
Storage - electromechanically operated electronics enclosure
Storage - lockable acrylic console door
Storage - under footrest
Window - opening window w/screen
Windshield - tempered glass windshield
Windshield washer - freshwater
Windshield wiper

Deluxe Lean Bar

Footrests
Livewell - 47-gallon (177.9 l) insulated raw water livewell w/light, full column distribution inlet & ob drain (1100 GPH pump) (4164 LPH)
Rigging station - freshwater sink w/pullout faucet & insulated bait box
Rod holders (2)
Seating - lean bar mounted Deluxe II helm chairs (2)
Storage - lockable bulk storage
Storage - lockable tackle trays

OPTIONAL FEATURES

Bow thruster
Casting platform insert w/cushions
CE certification package
Convenience package - battery charger & dockside power w/galvanic isolator
Head - marine head w/electric flush (10-gallon) (37.9 l)
Lighting - underwater LED (2)
Outrigger kit - 15-ft. (4.6 m) radial T-top mounted (w/T-top option only)
Painted hull
Painted T-top frame (requires T-top option)
Seating - lean bar mounted Deluxe III helm chairs w/foot rest & flip-up bolsters (2)
Sirius satellite radio system
Steering - power assist (standard w/TF300 & TF350 pkgs)
Stereo system w/MP3/auxiliary audio connections/ amplifier & fold down storage - satellite ready; speakers - console forward (2) & lean bar (2)
T-top (fiberglass) w/radio box, dome light, storage net, fore/aft spreader lights, rod holders (4) & outrigger plates
T-top speakers (2) (requires stereo & T-top options)
Table (bow)

CANVAS OPTIONS

(Available in ivory or navy)
T-top front & side curtains



Freedom 307

30' Dual Console

Beam Amidships: 10'7" (3.23 m)

Bridge Clearance: 6'11" (2.11 m)

w/Hardtop: 8'10" (2.69 m)

Center Line Length: 30'6" (9.30 m)

Cockpit Depth: 27" (0.69 m)

Cockpit Area: 80 sq. ft. (7.4 m²)

Hull Draft: 22" (0.56 m)

Maximum HP: 700 (522 kW)

Outboard Shaft Length: 25" (0.64 m)

Standard Fuel Capacity: 206 gal. (780 l)

Transom Width: 9'6" (2.90 m)

Weight w/o Engines: 7965 lb. (3613 kg)

STANDARD FEATURES

Safety

2 automatic bilge pumps (2600 GPH) (9842 LPH)
Basic flotation
Bow rail - low profile 316 grade stainless steel
Cockpit toe rails
Fire extinguisher holder
Nonskid fiberglass liner
Self-bailing cockpit w/cockpit drains (6)
Stainless steel through-hull fittings

Cockpit & Deck

100% hand laid hull & deck
Accessory outlet - 12V (2)
Anchor windlass
Battery select switches w/extra batteries
Cleats - flushmount (pop up)
Cockpit bolsters
Cockpit freshwater shower (recessed)
Cockpit lights-LED lighting
Companion grab rail
Compass
Cutting board
Deck hardware - 316 grade stainless steel through-bolted
Drink holders - stainless steel (17)
Factory engine pre-rigging
Fish box - 150-qt. (141.9 l) starboard insulated fish box w/ob drain
Fish box - 251-qt. (237.5 l) aft insulated fish box w/ob drain
Footrests - helm & companion
Forward bolsters
Fuel capacity - 206-gallon (780 l) tank
Head - lockable console w/stand up head area, sink, bulk storage, marine head w/macerator, 10-gallon (37.9 l) holding tank & pump out
Hydraulic trim tabs w/indicator & retractor
Integrated outboard mounting system w/swim platform & ladder

International lighting
Rod holders (4)
Rod storage racks - horizontal (8)
Rubrail - high density PVC w/stainless steel insert
Seating - electric extendable port lounge seat
Seating - electronically-adjustable helm bench seat
Seating - fold away aft bench seat w/cushion
Seating - port & starboard fish box cushions
Steering - hydraulic tilt
Steering wheel - 316 grade stainless steel
Stereo system w/MP3/auxiliary audio connections/amplifier & fold down mstorage - satellite ready; speakers - aft (2), bow (2) & helm (2)
Stern eyes - heavy-duty 316 stainless steel
Storage - aft box
Storage - forward anchor locker w/rode storage
Storage - port bow box
Storage - starboard console storage drawer
Storage - starboard lockable storage area w/service light
Table - bow (doubles in cockpit area)
Transom door - fiberglass
Washdown - freshwater
Washdown - pressurized raw water w/hose
Water tank - 32-gallon (121.1 l) freshwater
Wet bar w/sink, storage tray, storage drawer and trash compartment
Windshield - walk-through tempered glass windshield
Windshield washer - freshwater
Windshield wiper (starboard)

OPTIONAL FEATURES

Air conditioning - 3500 BTU
Bow thruster
CE certification package
Convenience package - battery charger & dockside power w/galvanic isolator
Deluxe bar w/grill, inverter & refrigerator (replaces sink)
Hardtop w/radio box, storage net, spreader lights & outrigger plates
Hardtop speakers (2) in lieu of helm speakers
Hardtop top-mounted rod holders
Head - marine head w/electric flush (10-gallon) (37.9 l)
International AC electrical conversion - 220V 50Hz
Lighting - underwater LED (2)
Livewell - 32-gallon (121.1 l) aft insulated raw water livewell w/light, full column distribution inlet & ob drain (1100 GPH pump) (4164 LPH)
Outrigger kit - 15-ft. (4.6 m) radial hardtop mounted (hardtop option only)
Painted hull
Seating - starboard sleeper seat
Sirius satellite radio system
Ski pylon
Steering - power assist (standard w/TF300 & TF350 pkgs)
Sun platform insert w/cushion
Wet bar w/refrigerator

CANVAS OPTIONS

(Available in ivory or navy)
Aft curtain (hardtop or vista top)
Bow cover
Drop curtain (hardtop or vista top)
Hardtop front & side curtains
Lounge seat cover
Tonneau cover
Vista top w/boot
Vista top front & side curtains
Wet bar cover

The ultimate in boating satisfaction. The ultimate in versatility, ease of use, comfort, safety and convenience.

1. **The bow anchor locker** allows quick access to the anchor for safety. Many models have power windlasses with remote switches.
2. **Flush mount electronics areas** are standard on most models.
3. **Comfortable seating** throughout the boat is second to none. Our deluxe seating is fully adjustable for additional comfort. Flip up seat bolsters are available on many models.
4. **Sound systems** are available on nearly all Grady-Whites. They are standard on our larger models.
5. **Dry storage.** Every Grady has plenty, just what you need to enjoy many activities on the water. Room for tow tools and toys, fishing and dive gear, picnic supplies, towels, extra clothing, personal items and more.
6. **Easy to maintain and clean stainless steel lined drink holders** are everywhere you need them. Convenient, and fewer slippery spills for safety!
7. **Storage net** is easy to use, easy to get to and perfect for stowing lots of items you can see and quickly locate, especially personal flotation devices (PFDs) in the bigger ones!
8. **Enclosed head area.** Every Grady-White 20 feet and over offers a head or head option. That's great comfort for all-day adventures.
9. **Toe rails** are easy to maintain and provide additional safety when you lean over the gunwale.
10. **Take the rods along every trip!** There's room for plenty of rods on every Grady-White. Cabin models, T-tops and hardtops often have additional rod racks.
11. **Patented fold away aft seating** is available on most models, opening up more cockpit room. Big cockpits are a Grady-White feature.



12. **Grady-White's nonskid surfaces** are everywhere you step and really provide traction.
13. **Tackle storage** and rigging areas are located on most models.
14. **Insulated ice boxes and fish boxes** drain directly overboard by gravity on every Grady-White.
15. **Handholds** are where you naturally reach.
16. **Safety windshield** (some models have unbreakable acrylic)
17. **True self-bailing** boat directs water overboard by gravity whether at rest or underway. All scuppers drain overboard. Inspection ports are watertight. All Grady-Whites have automatic bilge pumps, with two pumps on most models over 20 feet. Our dedication to self-bailing cockpit integrity is unparalleled.
18. **All Grady-Whites have foam sprayed into the hull for level or basic flotation**, even though not required in boats 20 feet and over. This foam also adds strength, thermal insulation and deadens sounds. There is no boat brand with better flotation properties.
19. **Through-bolted 316 stainless steel hardware** is secured with locking nuts.
20. **Heavy-duty fiberglass transom door** is not only for big fish, but is a safety feature and provides easy access for tow sports, swimming, snorkeling, and more. Solid, 316 stainless transom door hardware is highlighted by a destroyer-sized latch with a positive locking mechanism for added safety.
21. **Aluminum transom brace** is bonded to the top of outboard transoms, which reinforces transom strength and distributes motor torque. On integrated bracket models, the brace is through bolted to the longitudinal stringer system.

You're in command. Boat Smart from the Start! Take a boating education course, and get a vessel safety check for your boat. For more information, contact: U.S. Coast Guard Auxiliary 877-875-6296/800-368-5647 or www.cgaux.org and U.S. Power Squadrons 888-367-8777 or www.usps.org.

\$5.00 ©2011 Grady-White Boats, Inc. • Grady-White Boats, P.O. Box 1527, Greenville, NC 27835 (252) 752-2111 www.gradywhite.com
Grady-White Boats, Inc. reserves the right to discontinue models, or change prices, specifications, materials, equipment, colors or designs at any time without incurring obligation. Weight and dimensions of models are approximate and may vary. Thanks to: Jerry Imber Photography; Ray Matthews Photography; Bruce Miller Photography; Chip Henderson Photography; Carder Frutiger, Aperture Studios, Dewane Frutiger/ASAP Photography, Adams and Longino Advertising; and especially to Grady-White owners.

5-YEAR
STRUCTURAL
HULL WARRANTY
See your dealer for details about our warranties.



For smartphones

Mixed Sources
Product group from well-managed forests, controlled sources and recycled wood or fiber
www.fsc.org Cert no. SW-COC-002351
© 1996 Forest Stewardship Council



The NMAA Certified label on a Grady-White boat is your proof it meets, and often exceeds, industry quality and safety standards.

