



GRADY-WHITE 2008

WELCOME TO THE GRADY LIFE!

Thank you so much for considering the purchase of a Grady-White!

Your boat buying decision is based on the expectation that you and your family will enjoy great days on the water backed by

reliable performance and exemplary customer service. For nearly 50 years, we at Grady-White have worked hard to meet and exceed those expectations by providing families with the ultimate boating experience. Ongoing input from Grady-White owners and enthusiasts has enabled us to continue to build superbly

engineered coastal boats with features that deliver all-day comfort and lots of family-and-fishing fun.

As you consider a Grady-White boat, we urge you to ask Grady owners their opinion of our products and our dealerships. Please note that Grady-White has been recognized for excellence in customer satisfaction by every third-party study ever conducted in the recreational marine industry. No one else in the coastal boat category can say that!

For 2008, we introduce the all-new *Canyon 336* center console and also feature the ideal coastal family boat, the *Tournament 275*, plus an innovative and exciting revamp of our breakthrough express cabin, the *Express 330*. There are dozens of upgraded product features on every Grady-White model and exciting new engine options for our larger boats. Visit your local dealer for the details.

No matter which of our 22 models is the perfect one for you and your family, when you “Get the Grady” you’ll enjoy support, camaraderie and boating pleasure for the long term. That’s the Grady Life. That’s the ultimate in boating satisfaction!

Happy Boating!

Eddie Smith, Chairman & CEO

Kris Carroll, President



GRADY-WHITE DELIVERS

The highest levels of customer satisfaction



Our boat owners say it best.

Read the customer testimonials in this catalog. Visit the Grady Life section of gradywhite.com and look at the photographs. Page through our *Anchorline* newsletters, and check the websites of Grady-White owners’ clubs nationwide. Our customers love to share stories about their great Grady moments and how well their boats are performing! These reflections are not the only benchmarks of owner enjoyment. Every third-party measure conducted in our industry for our category has resulted in reports of Grady-White Boats providing the highest levels of customer satisfaction.

In each of the years that J.D. Power and Associates has conducted studies in the marine industry, Grady-White shines. This past model year, Grady-White was recognized “Highest in Customer Satisfaction with Coastal Fishing Boats Six Times in a Row.” And,

Grady has been top ranked each year that the National Marine Manufacturers Association has compiled its Customer Satisfaction Index. Behind each of these very flattering rankings and awards are great dealers and happy customers making delightful memories. Making memories is what great boating is all about.

“Highest in Customer Satisfaction with Coastal Fishing Boats Six Times in a Row”



Grady-White received the highest numerical score for coastal fishing boats (17–28 feet) in the proprietary J.D. Power and Associates’ 2001–2003, 2005–2007 Boat Competitive Information Studies™. 2007 study based on 12,140 total responses, and measures 16 coastal fishing brands and owner opinions of 2005 and 2006 model year boats registered June 2005–May 2006. Includes offshore coastal boats 17–28 with/without cabins, mostly outboard, some stern-drive power. 2007 proprietary study results are based on experiences and perceptions of owners surveyed September–October 2006. Your experiences may vary. jdpower.com

Built to keep customers happy

Grady customers are happy because the company and our dealers are committed to providing the ultimate boating experience. The values, principles and systems with which we’ve operated for nearly 50 years, and the resulting product introductions, help ensure decades-long owner loyalty.

The physical qualities of the boats themselves provide product satisfaction. Features and controls, ride and handling, comfort and convenience, power and performance—all of these factors combine to deliver the on-the-water experience that our boat owners enjoy. Our dealers’ product knowledge helps you select the model and configuration that best suit your boating style. Dealer service schools and service certification assure the maintenance capability that keeps your boat running reliably.

Beyond the boats themselves, the day-to-day, year-after-year Grady Life experience is pure fun!

The Grady Life

There are many annual Grady-White dealer events, tournaments, cruises and fishing schools enjoyed all over the country. A large and growing number of Grady-White clubs share camaraderie throughout the year. The quarterly *Anchorline* newsletter is published by and for Grady owners, and there’s an online resource center found at gradywhite.com.

It’s the people at Grady-White who really assure that your experience is so pleasurable. The long-term employees and associates of our privately held company—often with relationships that span decades—actively keep in touch with you to make sure you keep having those Great Grady Days!

“I have been thoroughly impressed with Grady-White’s customer service team. They’ve been an invaluable resource both in accommodating requests for upgrade items and answering questions on the day-to-day function of the boat.”

—Scott Yetman
Newcastle, WA

Grady-Built: There is NO OTHER BOATING EXPERIENCE

like the one you'll enjoy in a Grady-White.



Since day one, Grady-White has built boats so solid, safe and reliable, and with such attention to detail, that the long-term cost of ownership is lower than other brands. That's value!

Quality, reliability, safety, performance and long lasting value

are why a Grady-White is your boat of choice. Every Grady-White is a product of a unique combination of saltwater heritage, superb engineering and craftsmanship, a dedication to safety, a culture of long-term private ownership, and a keen knowledge of family boating gained over years of experience. Every boat is "Grady-Built" to provide superior value and family enjoyment for many, many years. That's why a Grady-White boat is the ultimate in boating satisfaction.

"Good enough" just isn't good enough at Grady-White. We sweat every detail to help ensure a more delightful boating experience. This applies to items large or small, from the tiniest stainless screw to our huge, true self-bailing cockpits that move water overboard by gravity, not pumps. And safety? You won't find a boat with greater flotation properties than a Grady-White. As for performance, boat length for boat length, the impressive and exclusive SeaV²® hull designs deliver the best ride

in boating, in any water condition and at any speed. Constantly refining details like these is an ingrained part of our personality that results from long experience and careful listening to our customers—all adding up to greater value!

Eddie Smith has owned Grady-White Boats since 1968. Our president, Kris Carroll, joined the company in 1975. Our talent-rich team's total professional focus is on premium quality sportfishing boats. We employ many of the most skilled and dedicated boat craftsmen in the world. We are committed heart and soul to our customers and to the superior safety, reliability, performance and dependability of our products. With the ongoing investments in our physical plant, Grady-White continues to build fiberglass boats in the most complete and up-to-date manufacturing facility in the industry. Our long-term relationships with our associates, dealerships and suppliers support continuous product improvement.

Because your Grady-White is solidly Grady-Built, the long-term cost of ownership is extraordinarily low compared to other brands. Tougher hardware holds up and lasts longer. A superior structure and hull design mean a softer and drier ride, and less wear and tear. Every drink holder, every handhold, every square inch of storage, every feature speaks quality. No wonder a Grady-White commands top dollar in the used boat market when you're ready for your next Grady. That's long lasting value!



20' GRADY WHITE ADVENTURE
2003 Yamaha F200 60 hours. Excellent condition. All service records. \$47,500

22' GRADY WHITE TOURNAMENT
2002 225hp 4-Stroke Yamaha, bimini top, Raytheon GPS, bow seating. Excellent condition. \$46,900

Just compare the resale values when you're shopping. Look at the used boats classifieds. You'll see that a well cared for Grady commands a better price than other boats in the same category.

Grady-White: Historic highlights of a customer- and quality-focused company

1959

Glen Grady and Don White begin to build small, tough, high quality wooden "works of art" for coastal boating that perform even in rough seas.

1968

Inspired by the opportunity to invest in a tough, outdoor-oriented product, the Smith family purchases Grady-White and completes the changeover to fiberglass production.

1968-1972

Grady-White puts new systems of manufacturing, sales, customer satisfaction and distribution in place and begins to learn that feedback—positive or negative—is essential to success.

1972

Eddie Smith, with his team of managers and associates at his side, breaks ground on what, through continuous improvement and investment, remains today one of the most modern boat manufacturing facilities in the world.

1975-1980s

Grady-White introduces the *Hatteras 204-C Overnighter*, one of the company's first walkarounds, and gains a growing understanding that customers are the company's most important asset.

1989-1990s

The *Marlin 28* introduces Grady-White's breakthrough SeaV² hull, a revolutionary design that delivers a soft, dry, true-tracking ride plus stability at lower speed. The decision is made to retain limited production status to enhance quality.

1993

Grady-White's commitment to customer satisfaction, input and involvement is renewed and strengthened as Eddie Smith chooses Kris Carroll, a company veteran, as Grady-White's new president.

2001

In the first J.D. Power and Associates study of the marine industry, Grady-White is ranked "Highest in Customer Satisfaction with Center Console Boats."

2002

Grady-White's *Express 330* is named *Boating Magazine's* Boat of the Year. Grady-White goes "Two for Two," ranked "Highest in Customer Satisfaction With Coastal Fishing Boats Two Years In a Row."

2003

A plant expansion begins a new era of Grady-White manufacturing. The completely integrated boat building facility provides customers the ongoing quality and value that result from efficiency and productivity in manufacturing.

2005

Grady-White's newest flagship, the *Express 360*, is introduced. The *Express 360* is the largest outboard powered express cabin model to date, chockful of big sportfisher features.

2007

Grady-White is again awarded for superior customer satisfaction when ranked "Highest in Customer Satisfaction With Coastal Fishing Boats (17-28 feet) Six Times in a Row" by J.D. Power and Associates. Grady continues to be recognized for excellence in every study conducted in the marine industry.

2007-2008

Grady-White continues to solicit dealer, associate and customer input to create new products like the *Canyon 336* and the *Tournament 275*, and takes full advantage of advancing engine and manufacturing technologies.



Grady-Built:

THE FINEST MATERIALS

mean built-in value and security.



Our patented fold away aft bench seat is a result of our process of seeking customers' advice on the kinds of material and detail that work best. This means hardware and fixtures not only fit their function but that everything is placed right where you need it.

Our 316 grade stainless steel hardware initially costs more than the industry standard 304 grade because of the expensive nickel and chromium in the alloy, plus molybdenum. Cast parts are passivated in acid to remove casting impurities, then buffed, then passivated and buffed again. We test sample batches in our "instant ocean" salt bath. The result is hardware—such as our through-hull fittings—that's strong and durable even after years in a saltwater environment.



Whether we utilize a traditional glass laminate or a new composite or core material depends on the application. No matter which material we select, Grady-White's extensive in-house and on-the-water tests ensure long lasting value and low cost of ownership.

Cabins are handsome, with eye-pleasing, durable fabrics. We test appliances including microwaves, satellite radios, stereos and flat screen TVs and DVD players. Galley and head fixtures are the very best available.

RTM (Resin Transfer Molded) parts such as fish box lids, hardtops and bow pulpits are solid and durable. RTM is especially important for fish box lids because the smooth underside surface is easier to clean than the rough glass painted surfaces found on competitive products.

Gunwale mounted rod holders are chrome-over-bronze, which is impervious to UV rays and stronger than plastic.

Super strong and durable, polyethylene trim work and toe rails are tough for the long haul, plus they are low maintenance and their good looks last indefinitely.

Grab rails, handholds, handles, swim ladders and transom door latches are battleship-tough. Through-bolted cleats plus bow and stern eyes are custom made for us. You get what you pay for with Grady: long lasting value. Years of trouble-free use and durable material add up to a very low cost of ownership with excellent function and safety.



Built by craftsmen. Not only do we use the best, most proven materials available, we fit and finish our boats with unmatched precision. Compare. Take a close look. Grady-White workmanship is clearly superior.

Grady-Built: BUILT BY CRAFTSMEN

superbly engineered through customer input



Our electromechanically operated electronics enclosures have dual functions. They lock up your valuable electronics, plus the height is adjustable so screens are easy to see in any light no matter how tall you are.

The people who design and engineer Grady-Whites

are avid boaters themselves. Through ongoing contact with our boat owners, we create customer-driven designs that are thoroughly tested and constantly refined along the North Carolina coast to assure superb performance in the toughest conditions.

Hand laid fiberglass provides an unmatched laminate structure. Only 100% hand lay-up assures a uniform thickness for strength and structural stiffness. Grady-White uses this tried and true method, fitting patterned pieces of fiberglass to deliver consistent laminate thickness on every boat. The resin for every part is metered and measured so each has an optimal glass-to-resin ratio. Stringer systems are precision cut by computerized router and then glassed in while the hull is still in the mold so your SeaV² hull retains the correct shape. Our proven stringer grid system is consistently strong, light, phenomenally durable,

Stringer systems are glassed into place while the hull is in its mold, ensuring your Grady holds its shape.

and has a limited lifetime warranty. Closed cell foam sprayed in between the stringers adds strength and flotation.

Our super strong transom is not only solidly Grady-Built of the strongest materials, but reinforced with an angled aluminum brace to provide sure support for today's four-stroke engines.

This bracing supports the top motor hole mounts, distributing torque throughout the transom.

At the helm threshold of our cabin models, decks are joined to liners with double through bolting. Aft of the seat boxes, another through-bolted and fiberglassed system forms a "box grid" to secure the deck and liner together, giving Grady-Whites support not found in other boats. All adding up to lasting value!



Skilled craftsmen apply hand laid fiberglass with precisely the right thickness and resin ratios. Top quality components assembled with skill mean you get quality, reliability and performance over the long haul.



Our latest plant expansion began operation in 2003, making ours the most productive, efficient and completely integrated boatbuilding facility in the world today. This furthers the highest product quality and longest lasting value for you.

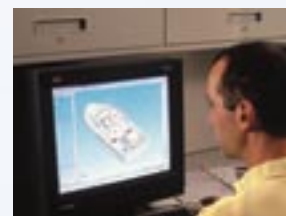

Every Grady-White offers comfort, safety and convenience.

- 1. The bow anchor locker** is convenient for storage and allows quick access to the anchor for safety.
- 2. Lockable electronics** or glove boxes are standard on most models.
- 3. Comfortable helm and companion seating.** Our deluxe seating is fully adjustable for additional comfort.
- 4. Sound systems** are available on most Grady-Whites. They are standard on our larger models.
- 5. Dry storage.** Every Grady has plenty—just what you need for towels, extra clothing and personal items.
- 6. Drink holders** are everywhere you need them. Convenient, and fewer slippery spills for safety!
- 7. Storage net** is easy to use and great for stowing lots of items.
- 8. An enclosed head** is a real surprise on smaller boats. All Grady-Whites over 21' (and several 20' models) offer a head or head option—a great comfort for all-day adventures.
- 9. Toe rails** are easy to maintain and provide safety when you lean over the gunwale.
- 10. Horizontal rod racks** and rod holders. Room for plenty of rods on every Grady-White. Cabin models often have additional rod racks.
- 11. Patented fold away aft seating** is available on many models, opening up more cockpit room. Big cockpits are a Grady-White feature.
- 12. Grady-White's nonskid surfaces** are everywhere you step and the design is proven reliable.
- 13. Cutting boards** and rigging areas are located on most models.
- 14. Insulated ice boxes,** fish boxes and sinks drain directly overboard by gravity on every Grady-White.
- 15. Handholds** are where you naturally reach.

Grady-Built:

SAFE AND SECURE:

the Grady-White difference



Step aboard a Grady and notice the high gunwales. These provide safety when you lean out over the water and are a real assurance when seas are rough.

Safety first. There is no more important issue in boat building than your security. So at Grady-White, we “overbuild” and “overdo” every detail. The sea does not compromise, and neither do we. Every Grady-White we deliver is National Marine Manufacturers Association (NMMA) product certified and accessories are NMMA type accepted. This demonstrates adherence to applicable American Boating and Yachting Council (ABYC) standards.



Every Grady-White is unsinkable. Check the certification tag on a Grady-White and you’ll see either level or basic flotation. Flotation properties are required on boats under 20 feet but not required on larger boats. While some competitive boats claim to be foam filled, they often don’t have enough for basic flotation.



Grady-White’s closed cell polyurethane foam provides unsurpassed flotation, adds strength and deadens sound. Every Grady-White is unsinkable. Our commitment to your safety is the highest priority at Grady-White.

Our boats have more than enough foam to keep the boat, motor and listed capacity of people afloat.

Grady-White’s sprayed in closed cell polyurethane foam won’t absorb water even if the hull is punctured, so the boat does not sink. The foam adheres to the stringers and hull and thus deadens sound and provides a solid feel.

The NMMA certified label on a Grady-White lets you know that it was built to meet, and often exceed, quality and safety standards established by the U.S. Coast Guard and the ABYC. These standards include 33 categories covering electrical systems, powering, flotation, fuel systems and navigation lights. Certified boats must also pass rigorous annual inspections from independent third-party inspectors. As a result, U.S. Coast Guard statistics show NMMA Certified boats have far fewer recalls due to safety issues than non-certified boats.



The certification tags tell the story. Although flotation properties are not required for boats over 20', every Grady-White provides either level or basic flotation.



For your family’s safety, there is no better choice than a Grady-White. Proven nonskid surfaces, wide walkarounds, grab rails and handholds are all part of your Grady’s lasting value.

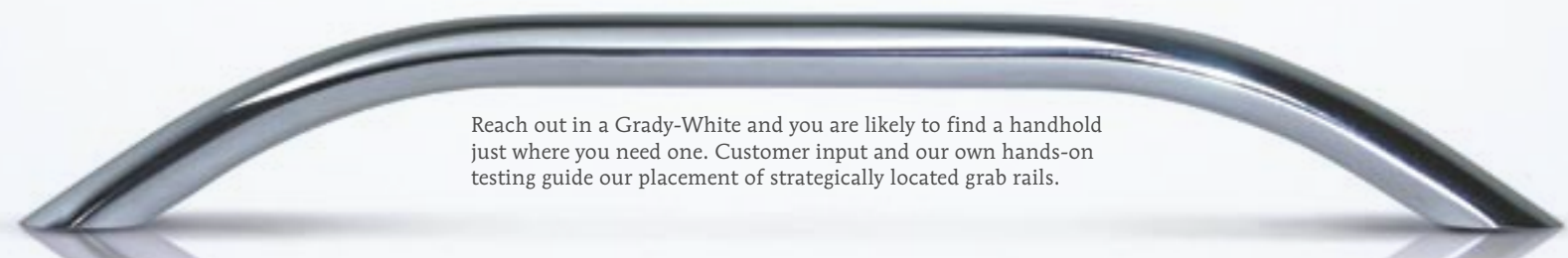

Reach out in a Grady-White and you are likely to find a handhold just where you need one. Customer input and our own hands-on testing guide our placement of strategically located grab rails.

Grady-Built:

THE ULTIMATE OFFSHORE DESIGN:

Grady-White exclusive SeaV²® hulls



Look carefully at a Grady-White running. You can actually see three wakes coming off the hull. This is a reflection of the smooth and dry trademark Grady-White ride.



Often imitated but never equaled, there is no ride like Grady-White’s. A Grady-White exclusive SeaV² hull offers the industry’s best combination of seakeeping, dryness, performance and speed. Grady-White factory rigs four-stroke engines exclusively so the SeaV² hull is especially well balanced for the optimum performance of these new power sources. Unlike other brands, a SeaV² hull design has no two places on the keel where the deadrise is the same. The vee continuously sharpens from the transom to the bow stem. A SeaV² hull design with 20 degrees of deadrise at the transom will have around 30 degrees amidships—more than even the most radical older deep vee designs. The deeper vee forward means a softer ride at sea. Less vee at the transom coupled with wide chines provide stability at rest and when trolling.

A SeaV² hull tracks as if the boat is on rails. The series of wedges that form a SeaV² hull have tremendous righting force providing

incredible tracking in quartering seas and especially in following seas. There are no rounded shapes to behave like a ball in the water that knows no upright position.

Strakes and chines knock the spray down cold. Check the spray coming off a SeaV² hull. You can actually see three bow wakes in smooth water. Those are the individual deflectors working. This is the reason SeaV² hulls are drier running than boats with rounded sections that blow spray past the strakes and chines and into the cockpit.

Grady-White delivers a deep vee ride with modified vee efficiency. Unlike other deep vee hulls, SeaV² hulls provide a soft ride without fuel efficiency loss. A SeaV² hull slices through seas effortlessly with a sharp point of entry, and the varying deadrise builds buoyancy that lifts the boat as it proceeds through waves. The result: better performance.

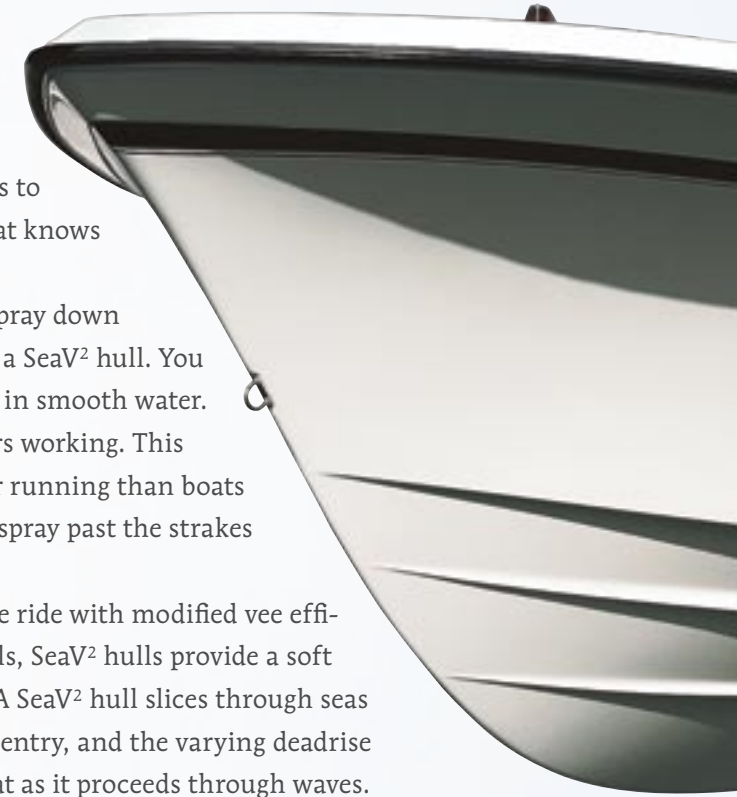

A sharp point of entry and a continuously variable deadrise down to a flatter stern mean wave cutting at speed and stability at rest.

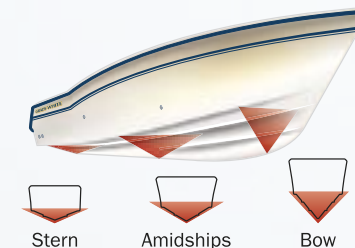

Like a series of sea-cutting wedges

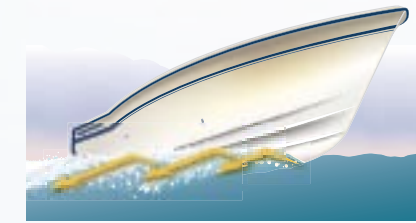

Strakes and chines knock down spray.

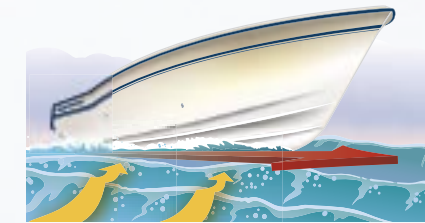

Tracks in quartering seas



Sportsman 180

18' CENTER CONSOLE

"The 180 is the perfect family boat. We like the safety of the high gunwales. Our five-year-old son, Jake, says it is the best boat for fishing, crabbing and taking rides with Rocky, his Grady Buddy."

—HANK AND KAREN KOWALSKI, WENONAH, NJ
SPORTSMAN 180 OWNERS

Sportsman 180 | 18' CENTER CONSOLE

Beam Amidships: 7'5"

Bridge Clearance: 5'7"

Center Line Length: 17'10"

Cockpit Depth: 22"

Cockpit Square Footage: 48 sq. ft.

Hull Draft: 14"

Maximum HP: 150

Outboard Shaft Length: 25"

Standard Fuel Capacity: 60 gal.

Transom Width: 7'2"

Weight w/o Engine: 1800 lb.

For detailed specifications see page 57.



Tournament 185

18' DUAL CONSOLE

"My father-in-law owns his second Grady-White, a Sailfish 282. My wife and I wanted a smaller open bow boat for our two young boys so we could play around, fish, and investigate the smaller waterways off the Rappahannock River yet still be able to venture into the Chesapeake Bay with safety and reliability."

—MIKE AND ERIN KUHLA, RICHMOND, VA
TOURNAMENT 185 OWNERS

Tournament 185 | 18' DUAL CONSOLE

Beam Amidships: 7'5"

Bridge Clearance: 5'1"

Center Line Length: 17'10"

Cockpit Depth: 21"

Cockpit Square Footage: 42 sq. ft.

Hull Draft: 14"

Maximum HP: 150

Outboard Shaft Length: 25"

Standard Fuel Capacity: 60 gal.

Transom Width: 7'2"

Weight w/o Engine: 2250 lb.

For detailed specifications see page 57.



- 1 - Bow casting platform
- 2 - Forward console with seating and bow anchor locker
- 3 - Console with lockable storage and electronics box
- 4 - Bow fish box

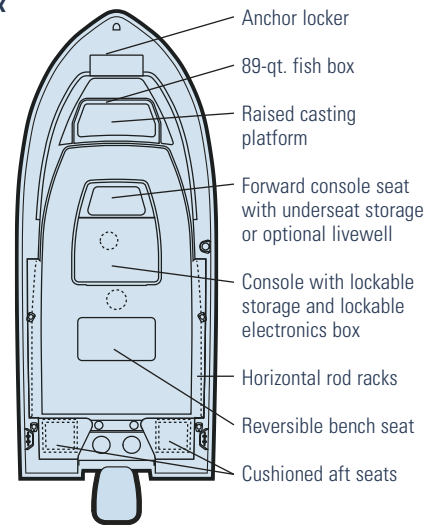

- 1 - Helm station
- 2 - Bow seating with optional forward bolsters
- 3 - Port console storage
- 4 - Starboard console storage

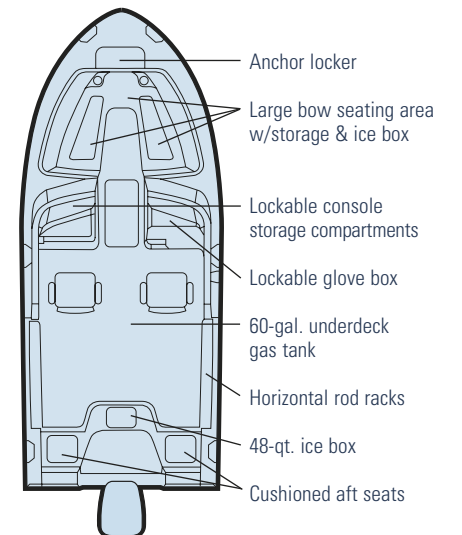



Tournament 205

20' DUAL CONSOLE

"We are blown away with the fit and finish of our *Tournament 205*. Watersports, casual fishing, cruising—it does it all! We've even gone offshore fishing and the boat performed flawlessly."

—KIM BAILEY AND RUSSELL SMALL, LEWES, DE
TOURNAMENT 205 OWNERS

Tournament 205 | 20' DUAL CONSOLE

Beam Amidships: 8'1"

Bridge Clearance: 5'7"

Center Line Length: 20'4"

Cockpit Depth: 25"

Cockpit Square Footage: 47 sq. ft.

Hull Draft: 15"

Maximum HP: 250

Outboard Shaft Length: 25"

Standard Fuel Capacity: 82 gal.

Transom Width: 7'10"

Weight w/o Engine: 2810 lb.

For detailed specifications see page 57.



- 1 - Helm station
- 2 - Forward seating with insulated fish box
- 3 - Cockpit forward with optional port sleeper seat
- 4 - Lockable enclosed head area with storage nets

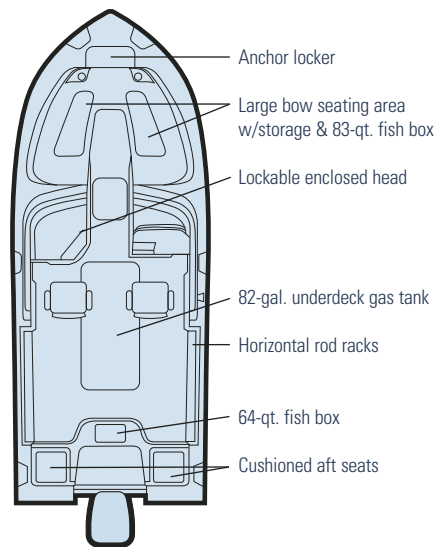



Adventure 208

20' WALKAROUND CABIN

"This boat handles the rough stuff like no other 20-foot boat I've been in. I do a lot of fishing with my pals, and my family likes cruising to the beach and riding across Biscayne Bay to Key Largo for the best conch fritters in the world!"

—NESTOR MARTINEZ, MIAMI, FL
ADVENTURE 208 OWNER

Adventure 208 | 20' WALKAROUND CABIN

Beam Amidships: 8'1"

Bridge Clearance: 5'9"

w/Hardtop: 8'

Center Line Length: 20'4"

Cockpit Depth: 25"

Cockpit Square Footage: 41 sq. ft.

Hull Draft: 15"

Maximum HP: 250

Outboard Shaft Length: 25"

Standard Fuel Capacity: 82 gal.

Transom Width: 7'10"

Weight w/o Engine: 2900 lb.

For detailed specifications see page 58.



- 1 - Cabin interior
- 2 - Cushioned aft seating
- 3 - Helm station with lockable electronics box
- 4 - Cockpit forward with optional cockpit bolsters

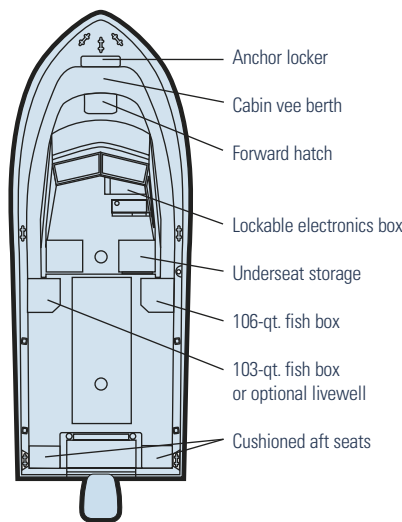



Escape 209

20' CENTER CONSOLE

"I fish water from two feet to 200 feet as a salmon guide. My *Escape 209* gets me in skinny water off the beach for fly fishing, and deep water for what we call 'mooching' or drifting. There is not another boat built that I want. This hull rides dry and lands soft."

—CAPTAIN KEITH ROBBINS, SEATTLE, WA
ESCAPE 209 OWNER

Escape 209 | 20' CENTER CONSOLE

Beam Amidships: 8'1"

Bridge Clearance: 5'9"

w/T-top: 7'8"

Center Line Length: 20'4"

Cockpit Depth: 25"

Cockpit Square Footage: 51 sq. ft.

Hull Draft: 15"

Maximum HP: 250

Outboard Shaft Length: 25"

Standard Fuel Capacity: 82 gal.

Transom Width: 7'10"

Weight w/o Engine: 2600 lb.

For detailed specifications see page 58.



- 1 - Cockpit forward** with optional T-top and lean bar with tackle and bulk storage
- 2 - Insulated bow fish boxes** with overboard drains
- 3 - Aft cockpit** with fold down motorwell bulkhead

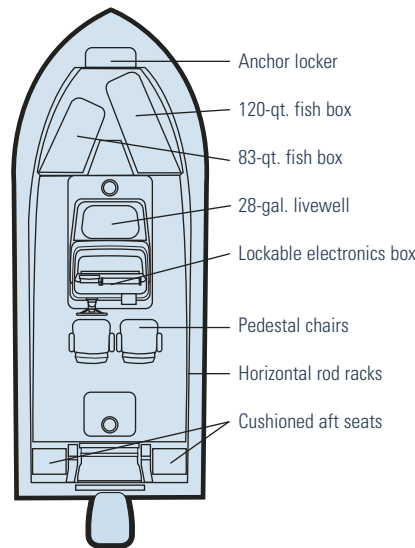



Fisherman 222

22' CENTER CONSOLE

"The 222 handles rough water better than boats twice its size. This boat is comfortable, very roomy for fishing and cruising, and easy to clean."

—JEFFREY ABEL, CROWNSVILLE, MD
FISHERMAN 222 OWNER

Fisherman 222 | 22' CENTER CONSOLE

Beam Amidships: 8'

Bridge Clearance: 6'2"

w/T-top: 8'

Center Line Length: 22'2"

Cockpit Depth: 25"

Cockpit Square Footage: 55 sq. ft.

Hull Draft: 16"

Maximum HP: 250

Outboard Shaft Length: 25"

Standard Fuel Capacity: 96 gal.

Transom Width: 7'11"

Weight w/o Engine: 3160 lb.

For detailed specifications see page 58-59.



- 1 - Aft cockpit** with fold down motorwell bulkhead and optional cockpit bolsters
- 2 - Insulated bow fish boxes** with overboard drains
- 3 - Cockpit forward** with optional T-top and lean bar with tackle and bulk storage

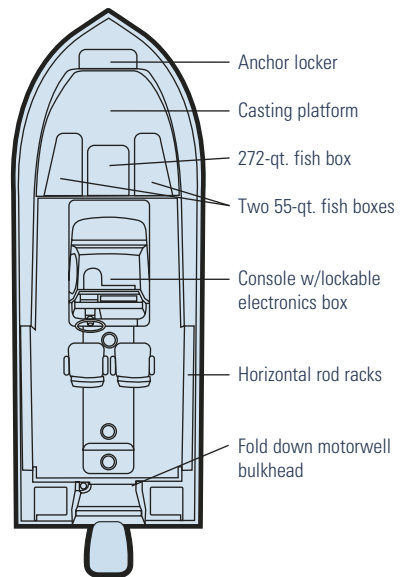

Fisherman 222



Tournament 225

22' DUAL CONSOLE

"The *Tournament 225* is the perfect family boat. It has all the fishing amenities for me, and the roominess and comfort that my wife and kids love. My kids enjoy long cruises along the Ocean City, MD, coastline and the ride is dry even when the seas get rough."

—RICK PROCTOR, FOREST HILL, MD
TOURNAMENT 225 OWNER

Tournament | 22' DUAL CONSOLE

Beam Amidships: 8'

Bridge Clearance: 5'6"

Center Line Length: 22'2"

Cockpit Depth: 25"

Cockpit Square Footage: 49 sq. ft.

Hull Draft: 16"

Maximum HP: 250

Outboard Shaft Length: 25"

Standard Fuel Capacity: 96 gal.

Transom Width: 7'11"

Weight w/o Engine: 3450 lb.

For detailed specifications see page 59.



- 1 - **Cockpit forward** with optional port sleeper seat and cockpit bolsters
- 2 - **Bow area** with optional sun platform with cushion
- 3 - **Lockable enclosed head area** with storage nets
- 4 - **Transom** with fold away bench seat, fish box and optional livewell

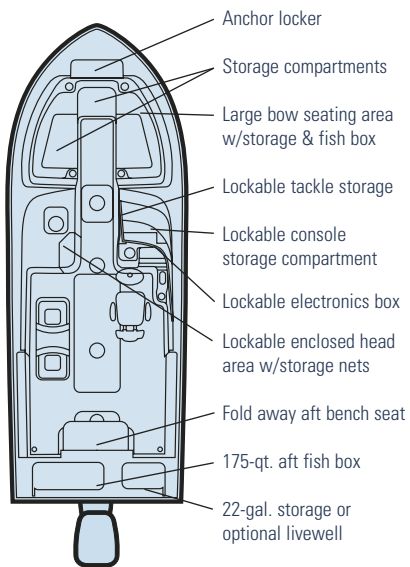

Tournament 225



Seafarer 226/228

22' WALKAROUND CABIN

"I want to tell you how much we are enjoying our Seafarer 226. Nothing compares to Grady-White's SeaV² hull. It's like going from a Tin Lizzy to a Lexus."

—FRANK MATTHES, HAMPTON BAYS, NY
SEAFARER 226 OWNER

Seafarer 226/228 | 22' WALKAROUND CABIN

Beam Amidships: 8'

Bridge Clearance: 6'2"

w/Hardtop: 8'4"

Center Line Length: 22'2"

Cockpit Depth: 26"

Cockpit Square Footage: 49 sq. ft.

Hull Draft: 16"

Maximum HP: 250

Outboard Shaft Length: 25"

Standard Fuel Capacity: 92 gal.

Transom Width: 7'11"

Weight w/o Engine:

226 (standard transom): 3385 lb.

228 (Grady Drive transom): 3510 lb.

For detailed specifications see page 59.



- 1 - Helm station with lockable electronics box
- 2 - Cabin access forward between helm and companion seats
- 3 - Grady Drive cockpit aft with optional bolsters (228)
- 4 - Cabin interior with port side sink; shown without auxiliary berth cushions

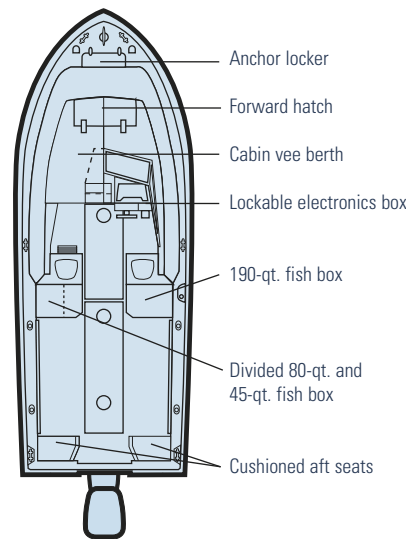

Seafarer 226/228



Gulfstream 232

23' WALKAROUND CABIN

"This is the boat we've always wanted. It's my Porsche! The 232 is the perfect size matched with the perfect power and reliability for us in the Gulf of Mexico."

—STUART RHODES, PALM ISLAND, FL
GULFSTREAM 232 OWNER

Gulfstream | 23' WALKAROUND CABIN

Beam Amidships: 9'3"

Bridge Clearance: 6'5"

w/Hardtop: 8'8"

Center Line Length: 23'5"

Cockpit Depth: 27"

Cockpit Square Footage: 56 sq. ft.

Hull Draft: 20"

Maximum HP: 400

Outboard Shaft Length:

Single: 25" Dual: 25"

Standard Fuel Capacity: 150 gal.

Transom Width: 8'10"

Weight w/o Engine:

232S: 4538 lb. 232D: 4605 lb.

For detailed specifications see page 60.

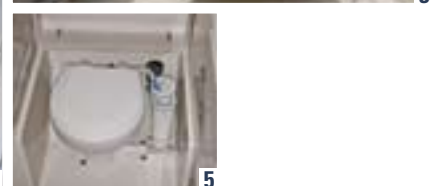

- 1 - Cockpit forward with Deluxe II helm chairs and lockable hardtop electronics boxes
- 2 - Cabin interior shown without auxiliary berth cushions
- 3 - Fold away aft bench seat
- 4 - Helm station with optional electronics flush mount kit
- 5 - Head enclosure in lockable cabin, with fold down cover

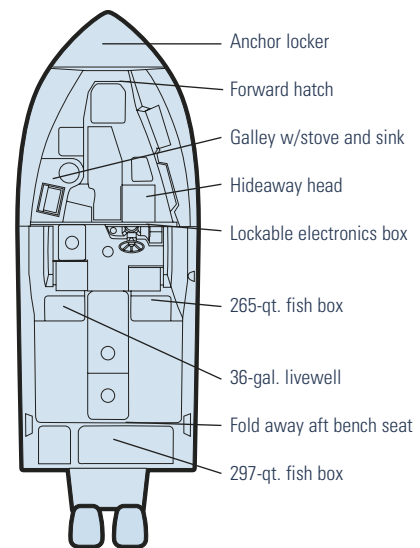



Advance 257

25' CENTER CONSOLE

"This is my third Advance 257 and my fifth new Grady-White. Grady quality, innovations and my Grady dealer's commitment to service keep me coming back for more."

—ROBERT HOWRY, LANCASTER PA
ADVANCE 257 OWNER

Advance 257 | 25' CENTER CONSOLE

Beam Amidships: 8'6"

Bridge Clearance: 7'

w/T-top: 8'5"

Center Line Length: 24'9"

Cockpit Depth: 27"

Cockpit Square Footage: 64 sq. ft.

Hull Draft: 20"

Maximum HP: 350

Outboard Shaft Length

Single: 30" Dual: 25"

Standard Fuel Capacity: 151 gal.

Transom Width: 7'10"

Weight w/o Engine: 4045 lb.

For detailed specifications see page 60.



- 1 - Forward fish boxes
- 2 - Console with lockable electronics box
- 3 - Lockable head enclosure with storage; shown with optional portable head

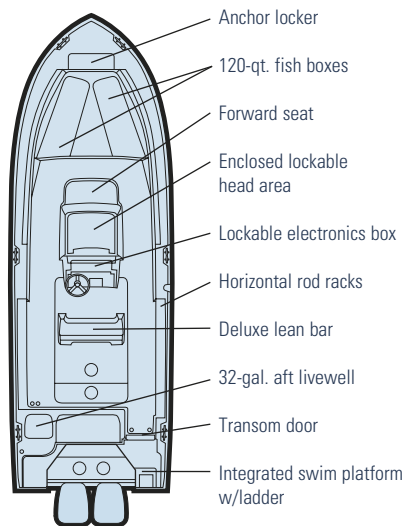

Advance 257



Journey 258

25' WALKAROUND CABIN

"On a Tarpon Coast Grady-White Boat Club trip to Key West and Dry Tortugas we encountered rough seas. Our Journey 258 took them in stride. One of the reasons we bought the 258 was for the sea handling capability and that paid off on this trip!"

—DAN AND JULI EISENBERG, ENGLEWOOD, FL
JOURNEY 258 OWNERS

Journey 258 | 25' WALKAROUND CABIN

Beam Amidships: 8'6"

Bridge Clearance: 6'6"

w/Hardtop: 8'8"

Center Line Length: 24'9"

Cockpit Depth: 27"

Cockpit Square Footage: 55 sq. ft.

Hull Draft: 20"

Maximum HP: 350

Outboard Shaft Length

Single: 30" Dual: 25"

Standard Fuel Capacity: 127 gal.

Transom Width: 7'10"

Weight w/o Engine: 4320 lb.

For detailed specifications see page 60-61.

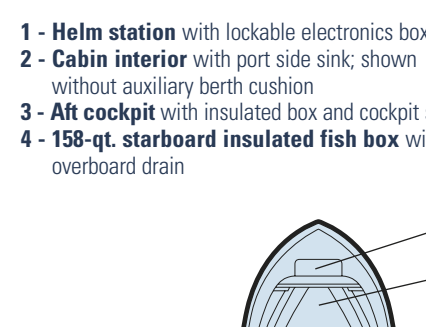

- 1 - Helm station with lockable electronics box
- 2 - Cabin interior with port side sink; shown without auxiliary berth cushion
- 3 - Aft cockpit with insulated box and cockpit shower
- 4 - 158-qt. starboard insulated fish box with overboard drain

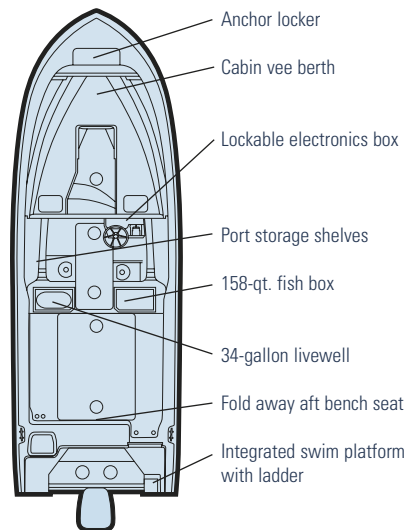



Chase 273

27' CENTER CONSOLE

"Whether fishing for walleye, or riding to the islands on Lake Erie with the family, I love my 273. When you buy a Grady-White, it's like joining a new family—the dealer, the factory, and fellow Grady owners are all great people."

—AL MICHAEL, MASSILLON, OH
CHASE 273 OWNER

Chase 273 | 27' CENTER CONSOLE

Beam Amidships: 8'6"

Bridge Clearance: 6'9"

w/T-top: 8'3"

Center Line Length: 26'11"

Cockpit Depth: 27"

Cockpit Area: 65 sq. ft.

Hull Draft: 20"

Maximum HP: 500

Outboard Shaft Length

Single: 30" Dual: 25"

Standard Fuel Capacity: 205 gal.

Transom Width: 7'10"

Weight w/o Engine: 4843 lb.

For detailed specifications see page 61.



- 1 - **Bow fish boxes** convert to bow seats (optional casting platform available)
- 2 - **Helm console** with electromechanically operated electronics enclosure
- 3 - **Lockable rod storage** under gunwales keeps rods secure and safe
- 4 - **Fold away aft bench seat**, livewell, 185-qt. fish box and transom door

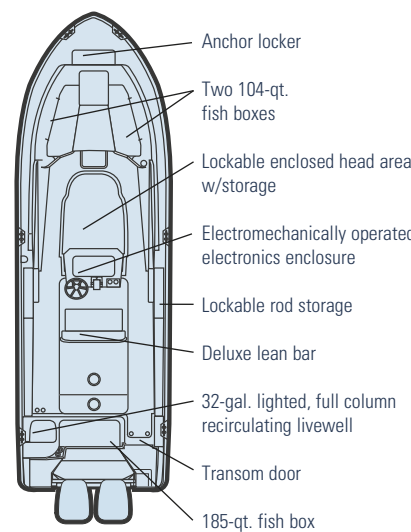

Chase 273





Tournament 275

27' DUAL CONSOLE

"This is our third *Tournament* model. It's the perfect combination boat for fishing and pleasure. We like the open bow feature, and the electromechanical sleeper seat option is great."

—BETTY SUE AND JOHNNY BURKE
WRIGHTSVILLE BEACH, NC
TOURNAMENT 275 OWNERS

Tournament 275 | 27' DUAL CONSOLE

Beam Amidships: 8'6"

Bridge Clearance: 6'3"

w/Hardtop: 8'5"

Center Line Length: 26'11"

Cockpit Depth: 27"

Cockpit Area: 60 sq. ft.

Hull Draft: 20"

Maximum HP: 500

Outboard Shaft Length

Single: 30" Dual: 25"

Standard Fuel Capacity: 200 gal.

Transom Width: 7'10"

Weight w/o Engine: 4972 lb.

For detailed specifications see page 61.



- 1 - Deluxe cushioned bow seating** with optional table (doubles as cockpit area table)
- 2 - Optional companion seating area** with electronically-controlled extendable lounge seating
- 3 - Head area** with extended storage (shown with optional head)
- 4 - Aft fold away bench seating**, 185-qt. insulated fish box, 32-gal. insulated cooler or livewell

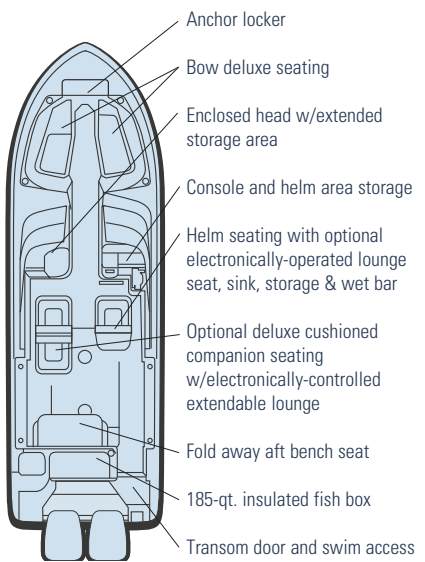

Tournament 275



Sailfish 282

28' WALKAROUND CABIN

"We covered 1300 nautical miles during a month-long cruise in the Sea of Cortez. The boat handled all conditions extremely well and was comfortable to live on."

—CHERYL AND DAVID BABINEAU, SANTA CRUZ, CA
SAILFISH 282 OWNERS

Sailfish 282 | 28' WALKAROUND CABIN

Beam Amidships: 9'6"

Bridge Clearance: 9'9"

Center Line Length: 28'

Length Overall (w/pulpit): 30'2"

Cockpit Depth: 28"

Cockpit Square Footage: 59 sq. ft.

Hull Draft: 21"

Maximum HP: 600

Outboard Shaft Length: 25"

Standard Fuel Capacity: 207 gal.

Transom Width: 9'

Weight w/o Engines: 6781 lb.

For detailed specifications see page 62.



- 1 - Cabin interior showing galley with Corian® cutting board and teak and holly cabin sole
- 2 - Cockpit forward with adjustable deluxe helm chair and optional companion bench seat
- 3 - Transom door, fold away bench seat, fish box and lift out box
- 4 - Helm station with optional electronics flush mount kit

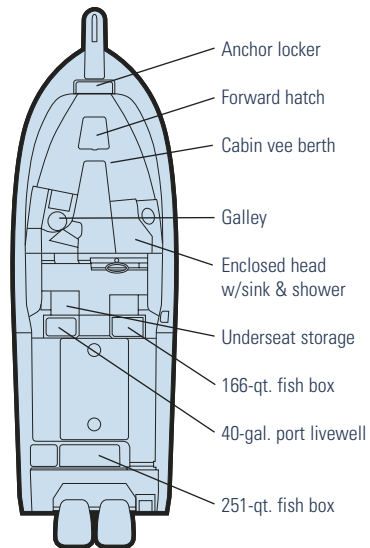



Release 283

28' CENTER CONSOLE

"We were on our shakedown trip in our new Release 283 and 15 minutes after our lines went in we boated a 40-lb. wahoo! This boat has 'the hum!'"

—LINDA AND JACK MONSELL, MARATHON, FL
RELEASE 283 OWNERS

Release 283 | 28' CENTER CONSOLE

Beam Amidships: 9'6"

Bridge Clearance: 7'7"

w/T-top: 9'

Center Line Length: 28'

Cockpit Depth: 27"

Cockpit Square Footage: 69 sq. ft.

Hull Draft: 20"

Maximum HP: 600

Outboard Shaft Length: 25"

Standard Fuel Capacity: 205 gal.

Transom Width: 9'

Weight w/o Engines: 5864 lb.

For detailed specifications see page 62.



- 1 - Deluxe lean bar rigging station** with livewell, tackle storage and freshwater sink
- 2 - Lockable head enclosure** with fold down cover, sink and storage
- 3 - Helm console** with electromechanically operated lockable electronics enclosure

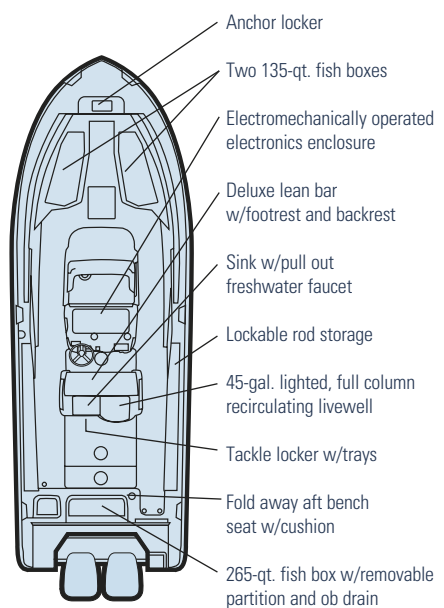

Release 283



Marlin 300

30' WALKAROUND CABIN

"Our son and his new bride left their wedding reception in our *Marlin 300*. Afterwards, we cruised down the Chesapeake and on to Hatteras, NC. The boat handled the rough waters of the Albemarle and Pamlico sounds with ease."

—MARGIE AND GARY REEDY, GRASONVILLE, MD
MARLIN 300 OWNERS

Marlin 300 | 30' WALKAROUND CABIN

Beam Amidships: 10'7"

Bridge Clearance: 9'9"

Center Line Length: 30'6"

Length Overall (w/pulpit): 32'7"

Cockpit Depth: 29"

Cockpit Square Footage: 74 sq. ft.

Hull Draft: 23"

Maximum HP: 700

Outboard Shaft Length: 25"

Standard Fuel Capacity: 300 gal.

Transom Width: 9'6"

Weight w/o Engines: 8221 lb.

For detailed specifications see page 62-63.



- 1 - Fold away bench seat, transom door, fish box and lift out box
- 2 - Cabin interior with teak and holly sole and galley
- 3 - Cabin interior with optional flat screen TV and DVD player
- 4 - Cockpit forward showing helm area and seating

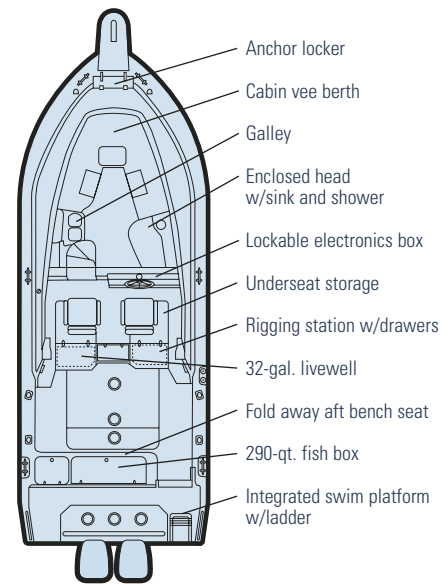

Marlin 300



Express 305

30' EXPRESS CABIN

"My 305 handles rough seas so well, and the running speed is fantastic. There's a lot of space at the rear for fishing, and the chill plate option for the fish box is great. And the cabin—we went to Bimini and stayed aboard several days comfortably."

—RAY NAVARRO, MIAMI, FL
EXPRESS 305 OWNER

Express 305 | 30' EXPRESS CABIN

- | | |
|---|---|
| Beam Amidships: 10'7" | Hull Draft: 23" |
| Bridge Clearance: 9'9" | Maximum HP: 700 |
| Center Line Length: 30'6" | Outboard Shaft Length: 25" |
| Length Overall (w/pulpit): 32'7" | Standard Fuel Capacity: 290 gal. |
| Cockpit Depth: 28" | Transom Width: 9'6" |
| Cockpit Square Footage: 63 sq. ft. | Weight w/o Engines: 8850 lb. |

For detailed specifications see page 63.



- 1 - Cabin interior featuring galley, teak dinette table, teak and holly sole
- 2 - Cockpit forward with transom door
- 3 - Helm station with electromechanically operated electronics enclosure
- 4 - Aft cockpit with fold down bench seat
- 5 - Lockable head enclosure

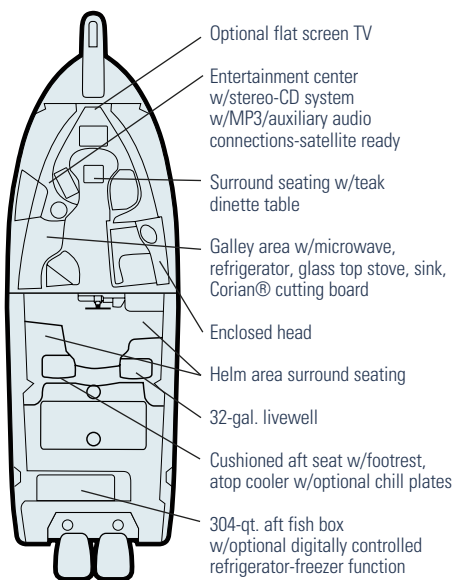

Express 305



Bimini 306

30' CENTER CONSOLE

“What a day on my Bimini 306! A double hook-up of a 58-lb. yellow fin and an 85-lb. big eye tuna! I can carry eight people fishing comfortably, and can go out in seas when others stay in port.”

—CMDR. JEFF PAFFORD, ANDROS ISLAND, BAHAMAS
BIMINI 306 OWNER

Bimini 306 | 30' CENTER CONSOLE

Beam Amidships: 10'7"

Bridge Clearance: 7'3"

w/T-top: 9'4"

Center Line Length: 30'6"

Cockpit Depth: 27"

Cockpit Square Footage: 75 sq. ft.

Hull Draft: 21"

Maximum HP: 700

Outboard Shaft Length: 25"

Standard Fuel Capacity: 290 gal.

Transom Width: 9'6"

Weight w/o Engines: 6500 lb.

For detailed specifications see page 63.



- 1 - Command seating helm area** with two deluxe adjustable sliding chairs and rigging station with freshwater sink, pullout faucet and insulated livewell
- 2 - Anchor locker** with windlass
- 3 - Lockable head enclosure** with fold down cover, sink and storage
- 4 - Electronics enclosure** electromechanically operated

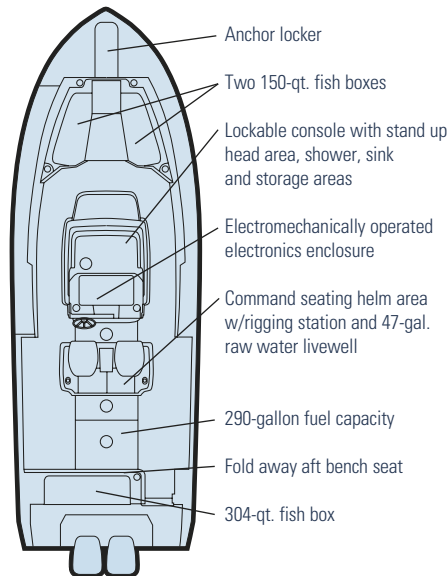



Express 330

33' EXPRESS CABIN

“From trips in the San Juan Islands to cruising in the Puget Sound, our Grady has been extremely comfortable and is a solid performer in all conditions.”

—MICHELE AND SCOTT YETMAN, NEWCASTLE, WA
EXPRESS 330 OWNERS

Express 330 | 33' EXPRESS CABIN

Beam Amidships: 11'7"

Bridge Clearance: 9'10"

Center Line Length: 33'6"

Length Overall (w/pulpit): 35'10"

Cockpit Depth: 29"

Cockpit Square Footage: 80 sq. ft.

Hull Draft: 25"

Maximum HP: 700

Outboard Shaft Length: 25"

Standard Fuel Capacity: 350 gal.

Transom Width: 10'6"

Weight w/o Engines: 10,840 lb.

For detailed specifications see page 64.



- 1 - Helm station with electromechanically operated electronics enclosure
- 2 - Flat screen 15" LCD TV w/DVD player & audio visual inputs
- 3 - Hardtop with net storage, electronics enclosure and rod holders
- 4 - Port side tackle station and sink
- 5 - 254-qt. aft deck insulated fish box and fold away aft bench seat

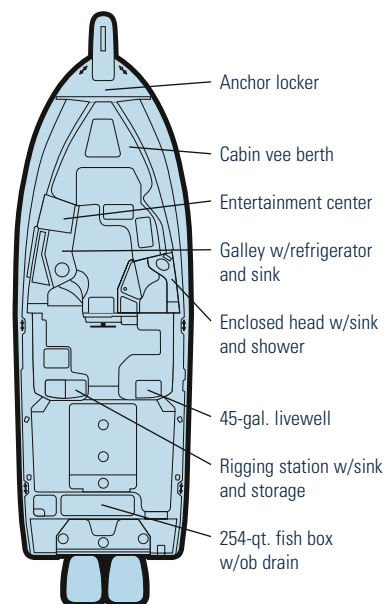

Express 330

Express 330

33' EXPRESS CABIN

"We honestly can't say enough good things about Grady-White and in particular the *Express 330*."

—MICHELE AND SCOTT YETMAN, NEWCASTLE, WA



"As a second generation Grady-White owner I can certainly understand why my dad bought his 1973 *Chesapeake*, after experiencing myself the quality and customer service still offered by Grady today," says Scott Yetman. "Having moved up to the *Express 330* from a *Sailfish 272*, our family thoroughly enjoys the solid ride and spacious accommodations. Whether it's weekends fishing with friends or week-long trips exploring the Northwest, we couldn't be more pleased with this boat. I am sure that as I have done with my own childhood memories of boating with family around Cape Ann, Massachusetts, our kids will think back on their days on Puget Sound when they purchase their first Grady!"

"The extra room around the cockpit, helm and cabin has provided us with comfortable living space without sacrificing fuel economy or travel time heading to our destinations. We honestly couldn't be more thrilled with our decision to purchase our *Express 330*!"



1



2



3



4



5

- 1 - Port helm seating with fold down bench
- 2 - Starboard helm seating
- 3 - Cabin interior featuring galley
- 4 - Helm area surround seating
- 5 - Cabin interior with teak and holly sole



6



7

- 6 - Cabin interior showing access to aft double berth
- 7 - Head enclosure with extensible shower faucet



Canyon 336

33' CENTER CONSOLE

"The Canyon 336 brings together what customers and dealers have asked for in a powerful, big center console, blending comfort and convenience with first-class fishing features that ensure success on those long offshore trips."

—DAVID NEESE, VICE PRESIDENT/ENGINEERING
GRADY-WHITE BOATS

Canyon 336 | 33' CENTER CONSOLE

Beam Amidships: 11'7"

Bridge Clearance: 8"

w/T-Top: 9"

Center Line Length: 33'6"

Cockpit Depth: 29"

Cockpit Square Footage: 80 sq. ft.

Hull Draft: 25"

Maximum HP: 700

Outboard Shaft Length: 25"

Standard Fuel Capacity: 350 gal.

Transom Width: 10'6"

Weight w/o Engines: 9200 lb.

For detailed specifications see page 64-65.



- 1 - Center helm lean bar with three deluxe sliding seats and footrest
- 2 - Rigging station with freshwater washdown, 104-qt. cooler, tackle drawers, storage, rod holders and knife & pliers holders
- 3 - Bow casting area with optional platform insert and cushions
- 4 - Lockable console interior with stand up head, shower, sink, rod storage, bulk storage and electrical access
- 5 - Console forward berth

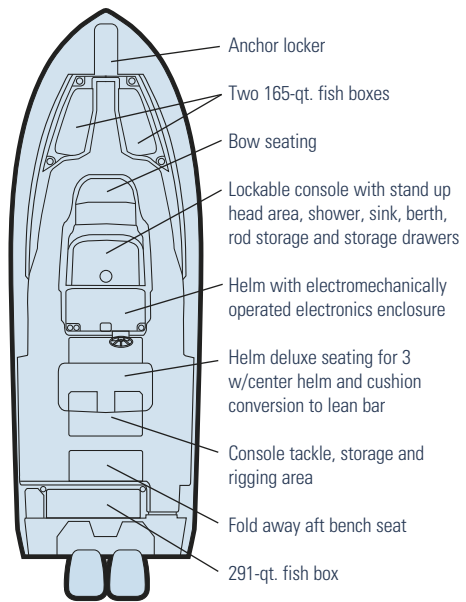



Express 360

36' EXPRESS CABIN

"After years of owning big inboard boats, we were looking for a large outboard. Grady had the largest on the market, and a good name."

—DON AND MARY ALFORD
INDIAN HARBOUR BEACH, FL
EXPRESS 360 OWNERS

Express 360 | 36' EXPRESS CABIN

Beam Amidships: 13'2"

Bridge Clearance: 10'6"

Center Line Length: 36'7"

Length Overall (w/pulpit): 39'3"

Cockpit Depth: 28"

Cockpit Square Footage: 96 sq. ft.

Hull Draft: 29"

Maximum HP: 1050

Outboard Shaft Length:

Port & Starboard Engines: 25"

Center Engine: 30"

Standard Fuel Capacity: 370 gal.

Freshwater Capacity: 65 gal.

Transom Width: 11'4"

Weight w/o Engines: 14,919 lb.

For detailed specifications see page 65.

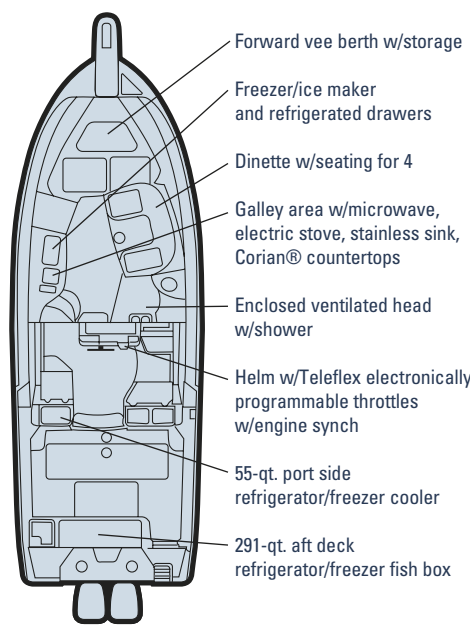

1, 2 - Helm surround seating includes innovative slide-away table, chart/storage area, additional fold away seating and deluxe cushioning.

3 - Helm includes deluxe adjustable seating, power assisted tilt steering, Teleflex electronically programmable throttles with engine synch mode, electromechanically operated electronics enclosure, and easy-access accessory fuse compartment.



Express 360

36' EXPRESS CABIN

“This is a quality performance boat. We get compliments all the time when we are on the water.”

—DON AND MARY ALFORD, INDIAN HARBOUR BEACH, FL
EXPRESS 360 OWNERS



Don and Mary Alford have owned large inboard boats for the past several years, the last being a 44'.

They were looking for a large outboard because, as Don says, “I got tired of climbing around in an engine room.” The Alfords are particularly pleased that their *Express 360* allows them to travel in more shallow water. “Our last boat drew four-and-a-half feet; Sebastian Inlet is only that deep at high tide so we’d spend hours going up to Port Canaveral and through a lock before we’d get to the fishing grounds. Now we can zip right out the inlet, cruising at 32 mph. We run faster and the fuel economy is better than our previous large inboard boat.”

Don likes the electronics enclosure that keeps the equipment safe. Both like the bow thruster. Another positive is Don doesn’t have to come down from a flybridge—he’s already where the fishing action is, and he and Mary can travel together on the same deck.

The Alfords are active Grady-White club members, and have been on several extended cruises with the Vero Beach Grady Bunch. They also take their grandchildren snorkeling. “The kids like the cabin aft berth—they consider it their little fort.” The Alfords also made a factory tour before their purchase. “We’ve been well taken care of by everyone associated with Grady-White. Our dealership is top-notch.”



- 1 - **Head/shower area** includes sink with Corian® counter surface, separate shower area with curtain, teak grate over shower drain, full length mirror, VacuFlush® head, lighted vanity mirror, teak shelves, storage areas.
- 2 - **Aft berth** includes 56" x 84" sleeping area with privacy curtain, teak foot well, teak hanging locker with cedar lining, bulk stowage, six rod holders.
- 3 - **291-quart aft deck refrigerator/freezer fish box** (shown) along with 55-quart refrigerator/freezer aft helm port box (not shown), both controlled by digital thermostat. Refrigeration coils are located in the walls of foam insulated boxes, increasing efficiency and greatly reducing the need for ice. Coil configuration and overboard drains keep boxes clean, open and easy to maintain.
- 4 - **Cockpit forward** showing 96 sq. ft. cockpit, helm station with deluxe chair, port and starboard lounge seating



- 5 - **Main cabin** includes teak and holly sole, seating for four at teak dinette table, variable accent lighting, 16,000 BTU air conditioning with zone cooling, expansive forward berth with storage and privacy curtain, and teak tambour enclosed storage areas.



▲ Hardtop front and side curtains for models 20' and up (330 shown). Drop curtain is available. Frames style and canvas vary per model.



▲ Ivory canvas option (275, 282, 283, 300, 305, 306, 330, 336 & 360)



▲ Hardtop with lockable radio box, spreader lights and rod holders (208)



▲ Hardtop with lockable radio boxes, spreader lights, side rod holders and overhead storage net (optional for cabin models 22'-27', standard for 28'-36')



▲ Center console Bimini top (180, 209, 222)



▲ Bow thruster (300, 305, 330, 336)



▲ Companion bench seat (300 shown)



▲ Jump seat (222)



▲ Companion bench seat (208, 226)



▲ Tournament sleeper seat with storage (185, 205, 225)



▲ Deluxe I helm chair



▲ Deluxe II helm chair

Factory options add fun to your Grady Life.

You'll enjoy your Great Grady Days even more when you accessorize with quality factory options that complement your boating style.



▲ Bow casting platform insert with removable cushions (273, 283, 306, 336)



▲ Walkaround series vista top and side curtains (208, 226/228, 232, 258)



▲ Gullstream auxiliary cushions



▲ Ski pylon



▲ Tournament series vista top and side curtains (185, 205, 225, 275)



▲ Bow pulpit shown with anchor windlass option



▲ Cabin rod racks



▲ Raw water livewell (lean bar option; 209, 222)

Visit www.gradywhite.com for the very latest specifications, performance reports, magazine reviews, virtual tours, additional photos and more detailed information on every Grady-White model.



Sportsman 180

18' CENTER CONSOLE

Beam Amidships: 7'5"
Bridge Clearance: 5'7"
Center Line Length: 17'10"
Cockpit Depth: 22"
Cockpit Square Footage: 48 sq. ft.
Hull Draft: 14"
Maximum HP: 150
Outboard Shaft Length: 25"
Standard Fuel Capacity: 60 gal.
Transom Width: 7'2"
Weight w/o Engine: 1800 lb.

STANDARD FEATURES

Safety
 Automatic bilge pump (1100 GPH)
 Bow rail - low profile 316 grade stainless steel
 Cockpit toe rails

Console grab rail
 Level flotation
 Nonskid fiberglass liner
 Self-bailing cockpit w/2 cockpit drains
 Stainless steel through-hull fittings

Cockpit & Deck
 100% hand laid hull & deck
 Casting platform (raised)
 Deck hardware - 316 grade stainless steel through-bolted
 Drink holders (2)
 Factory engine pre-rigging
 Fish box - 89-qt. insulated fish box/storage area w/ob drain
 Fuel capacity - 60-gallon tank
 Heavy-duty gunwale molding
 International lighting
 Rod holders (4)
 Rod storage racks - horizontal (4)
 Seating - bench seat w/reversible back
 Seating - aft seats (2)
 Spring line cleats
 Stern eyes - heavy-duty 316 stainless steel
 Storage - aft rigging compartments (2)
 Storage - forward anchor locker w/rode storage

Console
 Accessory outlet - 12V
 Cellular phone holder

Drink holders (2)
 Footrest
 Ice box - 45-qt. forward insulated ice box w/ob drain
 Rod storage holders - vertical (4)
 Seating - forward console seat
 Steering - no-feedback mechanical
 Steering wheel - 316 grade stainless steel
 Storage - lockable console storage
 Storage - lockable electronics box
 Storage net
 Windshield - Plexiglas windshield w/handrail

OPTIONAL FEATURES

Battery select switch w/extra battery
 Bow lifting ring
 Cockpit freshwater shower (recessed)
 High bow rail
 Hydraulic trim tabs w/indicator & retractor
 Livewell - 11-gallon insulated raw water livewell
 Seating - forward platform cushions
 Steering - hydraulic
 Steering - hydraulic tilt
 Swim platform w/ladder
 Washdown - pressurized raw water w/hose

Canvas Options
 Bimini top w/boot



Tournament 205

20' DUAL CONSOLE

Beam Amidships: 8'1"
Bridge Clearance: 5'7"
Center Line Length: 20'4"
Cockpit Depth: 25"
Cockpit Square Footage: 47 sq. ft.
Hull Draft: 15"
Maximum HP: 250
Outboard Shaft Length: 25"
Standard Fuel Capacity: 82 gal.
Transom Width: 7'10"
Weight w/o Engine: 2810 lb.

STANDARD FEATURES

Safety
 Automatic bilge pump (1100 GPH)
 Basic flotation
 Bow rail - low profile 316 grade stainless steel
 Cockpit toe rails
 Companion grab rail
 Nonskid fiberglass liner
 Self-bailing cockpit w/2 cockpit drains
 Stainless steel through-hull fittings

Cockpit & Deck
 100% hand laid hull & deck
 Accessory outlet - 12V
 Cockpit lights
 Deck hardware - 316 grade stainless steel through-bolted
 Drink holders (8)
 Factory engine pre-rigging
 Fish box - 64-qt. aft deck insulated fish box w/ob drain
 Fish box - 83-qt. starboard bow insulated fish box w/ob drain
 Fuel capacity - 82-gallon tank
 Head - lockable console head area w/storage nets
 Heavy-duty gunwale molding
 International lighting
 Rod holders (4)
 Rod storage racks - horizontal (6)
 Seating - aft seats (2)
 Seating - bow cushions
 Seating - helm & companion pedestal chairs
 Spring line cleats
 Steering - no-feedback mechanical
 Steering wheel - 316 grade stainless steel
 Stern eyes - heavy-duty 316 stainless steel
 Storage - forward anchor locker w/rode storage
 Storage - lockable console compartment

Canvas Options
 Aft curtain
 Bow cover
 Vista top & side curtains w/boot

Storage - port bow seat compartment
 Windshield - walk-through windshield
 Windshield wiper (starboard)

OPTIONAL FEATURES

Bow lifting ring
 Cockpit bolsters
 Cockpit freshwater shower (recessed)
 Forward bolsters
 Head - portable
 Hydraulic trim tabs w/indicator & retractor
 Livewell - 16-gallon insulated raw water livewell
 Seating - deluxe helm chair
 Seating - deluxe helm & companion chairs
 Seating - port sleeper seat w/storage drawer
 Sirius satellite radio system
 Ski pylon
 Steering - hydraulic (required w/F200, F225 & F250 engines)
 Steering - hydraulic tilt
 Stereo/CD system - satellite ready
 Sun platform w/cushion
 Swim platform w/ladder
 Washdown - pressurized raw water w/hose

Canvas Options

Aft curtain
 Bow cover
 Drop curtain
 Vista top w/side curtains & boot

Visit www.gradywhite.com for the very latest specifications, performance reports, magazine reviews, virtual tours, additional photos and more detailed information on every Grady-White model.



Adventure 208

20' WALKAROUND CABIN

Beam Amidships:	8'1"
Bridge Clearance:	5'9"
w/Hardtop:	8'
Center Line Length:	20'4"
Cockpit Depth:	25"
Cockpit Square Footage:	41 sq. ft.
Hull Draft:	15"
Maximum HP:	250
Outboard Shaft Length:	25"
Standard Fuel Capacity:	82 gal.
Transom Width:	7'10"
Weight w/o Engine:	2900 lb.

STANDARD FEATURES

Safety
Automatic bilge pump (1100 GPH)
Basic flotation
Bow rail - 316 grade stainless steel
Cockpit toe rails
Companion grab rail
Fold down motorwell bulkhead
Nonskid fiberglass liner
Nonskid recessed walkaround
Self-bailing cockpit w/4 cockpit drains
Stainless steel through-hull fittings

Cabin
Berth - forward vee berth
Cabin light
Forward hatch - low profile acrylic hatch w/screen
Lockable door w/screen & companionway hatch
Rod storage holders (4)
Storage - portable head compartment
Storage - under berth compartments (3)
Windows - opening windows w/screens (2)

Cockpit & Deck
100% hand laid hull & deck
Accessory outlet - 12V (2)
Cockpit lights
Deck hardware - 316 grade stainless steel through-bolted
Drink holders (6)
Factory engine pre-rigging
Fish box - 103-qt. port insulated fish box w/ob drain
Fish box - 106-qt. starboard insulated fish box w/ob drain

Footrests (helm & companion)
Fuel capacity - 82-gallon tank
Heavy-duty gunwale molding
International lighting
Rod holders (4)
Rod storage racks - horizontal (6)
Seating - aft seats (2)
Seating - helm & companion pedestal chairs
Seating - port & starboard fish box cushions
Spring line cleats
Steering - no-feedback mechanical
Steering wheel - 316 grade stainless steel
Stern eyes - heavy-duty 316 stainless steel
Storage - aft seat lift out boxes (2)
Storage - forward anchor locker w/rode storage
Storage - lockable electronics box
Storage - lockable storage under helm chair
Storage - tackle drawers under companion chair (2)
Storage nets
Windshield
Windshield wiper (starboard)

OPTIONAL FEATURES

Bow lifting ring
Bow pulpit
Cockpit bolsters
Cockpit freshwater shower (recessed)
Hardtop w/radio box, spreader lights & side mounted rod holders (4)
Hardtop top mounted rod holders
Head - portable
Head - portable w/deck pump out
Hydraulic trim tabs w/indicator & retractor
Livewell - 25-gallon insulated raw water livewell
Seating - companion bench seat
Seating - foredeck cushions
Steering - hydraulic (required w/F200, F225 & F250 engines)
Steering - hydraulic tilt
Swim platform w/ladder
Washdown - pressurized raw water w/hose

Canvas Options

Drop curtain (hardtop or vista top)
Hardtop front & side curtains
Vista top w/side curtains & boot



Escape 209

20' CENTER CONSOLE

Beam Amidships:	8'1"
Bridge Clearance:	5'9"
w/T-top:	7'8"
Center Line Length:	20'4"
Cockpit Depth:	25"
Cockpit Square Footage:	51 sq. ft.
Hull Draft:	15"
Maximum HP:	250
Outboard Shaft Length:	25"
Standard Fuel Capacity:	82 gal.
Transom Width:	7'10"
Weight w/o Engine:	2600 lb.

STANDARD FEATURES

Safety
Automatic bilge pump (1100 GPH)
Basic flotation
Bow rail - low profile 316 grade stainless steel
Cockpit toe rails
Console grab rail
Fold down motorwell bulkhead
Nonskid fiberglass liner
Self-bailing cockpit w/2 cockpit drains
Stainless steel through-hull fittings

Cockpit & Deck

100% hand laid hull & deck
Casting platform (raised)
Cockpit lights
Deck hardware - 316 grade stainless steel through-bolted
Drink holders (2)
Factory engine pre-rigging
Fish box - 83-qt. port insulated fish box w/ob drain
Fish box - 120-qt. starboard insulated fish box w/ob drain
Fuel capacity - 82-gallon tank
Heavy-duty gunwale molding
International lighting
Rod holders (4)
Rod storage racks - horizontal (6)
Seating - aft seats (2)
Seating - helm & companion pedestal chairs
Spring line cleats
Stern eyes - heavy-duty 316 stainless steel
Storage - aft rigging compartments (2)
Storage - forward anchor locker w/rode storage

Console

Accessory outlet - 12V (2)
Drink holders (2)
Livewell - 28-gallon forward insulated raw water livewell w/ob drain
Rod storage holders - vertical (6)
Seating - forward console seat w/cushion
Steering - no-feedback mechanical
Steering wheel - 316 grade stainless steel
Storage - lockable electronics box
Storage - lockable storage compartments (2)
Windshield - Plexiglas windshield w/handrail

OPTIONAL FEATURES

Bow lifting ring
Cockpit bolsters
Cockpit freshwater shower (recessed)
High bow rail
Hydraulic trim tabs w/indicator & retractor
Livewell (lean bar option only) - 23-gallon insulated raw water livewell w/cushion (in place of standard 28-gallon raw water livewell)
Seating - bench seat w/reversible back
Seating - forward platform cushions
Seating - lean bar w/backrest, footrest, tackle trays, lockable storage & rod holders (4)
Steering - hydraulic (required w/F200, F225 & F250 engines)
Steering - hydraulic tilt
Swim platform w/ladder
T-top w/radio box, dome light, storage net, spreader light & rod holders (4)
Washdown - pressurized raw water w/hose

Canvas Options

Bimini top w/boot
T-top front & side curtains



Fisherman 222

22' CENTER CONSOLE

Beam Amidships:	8'
Bridge Clearance:	6'2"
w/T-top:	8'
Center Line Length:	22'2"
Cockpit Depth:	25"
Cockpit Square Footage:	55 sq. ft.
Hull Draft:	16"
Maximum HP:	250
Outboard Shaft Length:	25"
Standard Fuel Capacity:	96 gal.
Transom Width:	7'11"
Weight w/o Engine:	3160 lb.

STANDARD FEATURES

Safety
Automatic bilge pump (1500 GPH)
Basic flotation
Bow rail - low profile 316 grade stainless steel
Cockpit toe rails
Console grab rail
Fold down motorwell bulkhead
Nonskid fiberglass liner
Self-bailing cockpit w/4 cockpit drains
Stainless steel through-hull fittings

Cockpit & Deck

100% hand laid hull & deck
Casting platform (raised)
Cockpit lights
Compass
Deck hardware - 316 grade stainless steel through-bolted
Drink holders (12)
Factory engine pre-rigging
Fish box - 52-qt. starboard bow insulated fish box w/ob drain
Fish box - 55-qt. port & starboard insulated fish boxes w/ob drain
Fish box - 175-qt. aft insulated fish box w/ob drain
Footrest (helm)
Forward bolsters
Fuel capacity - 96-gallon tank
Head - lockable console head area w/storage nets
Head - portable

Heavy-duty gunwale molding
Hydraulic trim tabs w/indicator & retractor
International lighting
Rod holders (4)
Rod storage racks - horizontal (6)
Seating - helm & companion pedestal chairs
Spring line cleats
Stern eyes - heavy-duty 316 stainless steel
Storage - aft deck lift out boxes (2)
Storage - forward anchor locker w/rode storage
Washdown - pressurized raw water w/hose

Console

Accessory outlet - 12V (2)
Drink holders (2)
Head - lockable console w/stand up head area & storage
Rod storage holders - vertical (6)
Seating - forward console seat w/cushion
Steering - hydraulic tilt
Steering wheel - 316 grade stainless steel
Storage - lockable electronics box
Storage - under footrest
Storage nets
Windshield - Plexiglas windshield w/handrail

OPTIONAL FEATURES

Bow lifting ring
Bow pulpit (includes high profile bow rail)
Cockpit bolsters
Cockpit freshwater shower (recessed)
Head - portable
Head - portable w/deck pump out
Head - portable w/in-line macerator
Livewell (lean bar option only) - 23-gallon insulated raw water livewell w/cushion
Outrigger kit - 15-ft radial T-top mounted
Seating - deluxe lean bar w/footrest, backrest, tackle trays, lockable storage & rod holders (4)
Seating - folding aft jump seats w/cushions (2)
Seating - forward platform cushions
Swim platform w/ladder
T-top w/radio box, dome light, storage net, spreader light, rod holders (4) & outrigger plates

Canvas Options

Bimini top w/boot
T-top front & side curtains



Tournament 225

22' DUAL CONSOLE

Beam Amidships:	8'
Bridge Clearance:	5'6"
Center Line Length:	22'2"
Cockpit Depth:	25"
Cockpit Square Footage:	49 sq. ft.
Hull Draft:	16"
Maximum HP:	250
Outboard Shaft Length:	25"
Standard Fuel Capacity:	96 gal.
Transom Width:	7'11"
Weight w/o Engine:	3450 lb.

STANDARD FEATURES

Safety
Automatic bilge pump (1500 GPH)
Basic flotation
Bow rail - low profile 316 grade stainless steel
Cockpit toe rails
Companion grab rail
Compass
Nonskid fiberglass liner
Self-bailing cockpit w/2 cockpit drains
Stainless steel through-hull fittings

Cockpit & Deck

100% hand laid hull & deck
Accessory outlet - 12V (2)
Cockpit freshwater shower (recessed)
Cockpit lights
Deck hardware - 316 grade stainless steel through-bolted
Drink holders (12)
Factory engine pre-rigging
Fish box - 52-qt. starboard bow insulated fish box w/ob drain
Fish box - 175-qt. aft insulated fish box w/ob drain
Footrest (helm)
Forward bolsters
Fuel capacity - 96-gallon tank
Head - lockable console head area w/storage nets
Head - portable

Heavy-duty gunwale molding
Hydraulic trim tabs w/indicator & retractor
International lighting
Rod holders (4)
Rod storage racks - horizontal (6)
Seating - bow cushions
Seating - deluxe helm & companion chairs w/adjustable pedestal
Seating - fold away aft bench seat w/cushion
Spring line cleats
Steering - hydraulic tilt
Steering wheel - 316 grade stainless steel
Stern eyes - heavy-duty 316 stainless steel
Storage - 22-gallon insulated aft storage compartment
Storage - forward anchor locker w/rode storage
Storage - forward bow seat compartment
Storage - lockable console storage compartment
Storage - lockable console tackle drawers
Storage - lockable electronics box
Storage - port bow seat compartment
Windshield - walk-through windshield
Windshield wiper (starboard)

OPTIONAL FEATURES

Bow lifting ring
Cockpit bolsters
Head - portable w/deck pump out
Head - portable w/in-line macerator
Livewell - 22-gallon insulated raw water livewell w/light, full column distribution inlet & ob drain (1100 GPH pump)
Seating - deluxe helm chair II
Seating - port sleeper seat w/storage drawer
Sirius satellite radio system
Ski pylon
Stereo/CD system - satellite ready
Sun platform w/cushion
Swim platform w/ladder (full width)
Swim platform w/ladder (small port side)
Washdown - pressurized raw water w/hose

Canvas Options

Aft curtain
Bow cover
Drop curtain
Vista top w/side curtains & boot



Seafarer 226/228

22' WALKAROUND CABIN

Beam Amidships:	8'
Bridge Clearance:	6'2"
w/Hardtop:	8'4"
Center Line Length:	22'2"
Cockpit Depth:	26"
Cockpit Square Footage:	49 sq. ft.
Hull Draft:	16"
Maximum HP:	250
Outboard Shaft Length:	25"
Standard Fuel Capacity:	125 gal.
Transom Width:	7'11"
Weight w/o Engine:	3226 (standard transom): 3385 lb. 228 (Grady Drive transom): 3510 lb.

STANDARD FEATURES

Safety
2 automatic bilge pumps (total 2200 GPH)
Basic flotation
Bow rail - 316 grade stainless steel
Cockpit toe rails
Companion grab rail
Fold down motorwell bulkhead (226 only)
Nonskid fiberglass liner
Nonskid recessed walkaround
Self-bailing cockpit w/4 cockpit drains
Stainless steel through-hull fittings

Cabin

Berth - forward vee berth
Cabin light
Forward hatch - low profile acrylic hatch w/screen
Lockable door w/screen & companionway hatch
Rod storage holders (4)
Sink
Storage - cabinet
Storage - portable head compartment
Storage - under berth compartments (3)
Windows - opening windows w/screens (2)

Cockpit & Deck

100% hand laid hull & deck
Accessory outlet - 12V (2)
Bait rigging area w/cutting board & drink holders (228 only)

Battery select switch
Cockpit freshwater shower (recessed)
Cockpit lights
Compass
Deck hardware - 316 grade stainless steel through-bolted
Drink holders (6)
Factory engine pre-rigging
Fish box - 72-qt. aft fish box (228 only)
Fish box - 190-qt. starboard insulated fish box w/ob drain
Fish box - divided port insulated fish box (80-qt. & 45-qt. sections w/ob drain)
Footrests (helm & companion)
Fuel capacity - 125-gallon tank
Heavy-duty gunwale molding
Hydraulic trim tabs w/indicator & retractor
International lighting
Rod holders (4)
Rod storage holders - vertical (4) (228 only)
Rod storage racks - horizontal (6)
Seating - aft seats (2)
Seating - helm & companion pedestal chairs
Seating - port & starboard fish box cushions
Spring line cleats
Steering - hydraulic tilt
Steering wheel - 316 grade stainless steel
Stern eyes - heavy-duty 316 stainless steel
Storage - aft lift out boxes
Storage - forward anchor locker w/rode storage
Storage - lockable helm station radio box
Storage - tackle drawers under helm & companion chairs
Storage nets
Water tank - 10-gallon freshwater
Windshield - ventilated windshield
Windshield wiper (starboard)

OPTIONAL FEATURES

Bow lifting ring
Bow pulpit
Cockpit bolsters
Hardtop w/radio box, storage net, spreader lights & side mounted rod holders (4)
Hardtop top mounted rod holders
Head - portable
Head - portable w/deck pump out
Head - portable w/in-line macerator
Livewell - 20-gallon port insulated raw water livewell (226)
Livewell - 20-gallon aft insulated raw water livewell (228)
Seating - companion bench seat
Seating - deluxe helm & companion chairs
Seating - foredeck cushions
Swim platform w/ladder
Swim platform w/ladder (full width) (228 only)
Washdown - pressurized raw water w/hose
Windshield wiper (port)

Canvas Options

Drop curtain (hardtop or vista top)
Hardtop front & side curtains
Vista top w/side curtains & boot

Visit www.gradywhite.com for the very latest specifications, performance reports, magazine reviews, virtual tours, additional photos and more detailed information on every Grady-White model.



Gulfstream 232

23' WALKAROUND CABIN

Beam Amidships:	9'3"
Bridge Clearance:	6'5"
w/Hardtop:	8'8"
Center Line Length:	23'5"
Cockpit Depth:	27"
Cockpit Square Footage:	56 sq. ft.
Hull Draft:	20"
Maximum HP:	400
Outboard Shaft Length	
Single:	25"
Dual:	25"
Standard Fuel Capacity:	150 gal.
Transom Width:	8'10"
Weight w/o Engine	
232S:	4538 lb.
232D:	4605 lb.

STANDARD FEATURES

Safety
2 automatic bilge pumps (total 2600 GPH)
Basic flotation
Bow rail - 316 grade stainless steel
Cockpit toe rails
Companion grab rail
Nonskid fiberglass liner
Nonskid recessed walkaround
Self-bailing cockpit w/4 cockpit drains
Stainless steel through-hull fittings

Cabin
Berths - 2 berths (upper & lower)
Cabin lights
Forward hatch - low profile acrylic hatch w/screen
Galley - portside galley w/sink
Ice box - insulated ice box w/ob drain
Lockable door w/screen & companionway hatch
Rod storage holders (2)
Storage - aft compartment
Storage - portable head compartment
Storage - under berth compartment
Storage - under sink compartment
Storage nets
Stove - butane
Windows - opening windows w/screens (2)

Cockpit & Deck
100% hand laid hull & deck
Accessory outlet - 12V (2)
Battery select box

Battery select switch
Cockpit freshwater shower (recessed)
Cockpit lights - LED cockpit lighting under gunwales
Compass
Cutting board
Deck hardware - 316 grade stainless steel through-bolted
Drink holders (9)
Factory engine pre-rigging
Fish box - 265-qt. starboard insulated fish box w/ob drain
Fish box - 297-qt. aft insulated fish box w/ob drain

Footrests - helm & companion (adjustable)
Fuel capacity - 150-gallon tank
Heavy-duty gunwale molding
Hydraulic trim tabs w/indicator & retractor
International lighting
Livewell - 36-gallon port insulated raw water livewell w/light, full column distribution inlet & ob drain (1100 GPH pump)
Rod holders (4)
Rod storage racks - horizontal (6)
Rubrail - high density PVC w/stainless steel insert
Seating - deluxe helm & companion chairs
Seating - fold away aft bench seat w/cushion
Seating - port livewell cushion
Seating - starboard fish box cushion
Spring line cleats
Steering - hydraulic tilt
Steering wheel - 316 grade stainless steel
Stern eyes - heavy-duty 316 stainless steel
Storage - forward anchor locker w/rode storage
Storage - lockable electronics box
Storage - tackle drawers under companion seat (2)
Storage - tackle trays under helm chair (2)
Washdown - pressurized raw water w/hose
Water tank - 12-gallon freshwater
Windshield - ventilated windshield
Windshield wipers

OPTIONAL FEATURES

Anchor windlass (must have bow pulpit)
Bow lifting ring
Bow pulpit
Cockpit bolsters
Cushions - auxiliary berth cushions
Electronics flush mount kit
Hardtop w/radio box, storage net, spreader lights & side mounted rod holders (4)
Hardtop top mounted rod holders
Head - marine head w/electric flush & 10-gallon holding tank
Head - marine head w/macerator, 10-gallon holding tank & pump out
Head - portable
Head - portable w/deck pump out
Head - portable w/in-line macerator
Outrigger kit - 15-ft. radial hardtop mounted (w/hardtop option only)
Rod storage - folding cabin rack (6)
Seating - deluxe helm chair II
Seating - foredeck cushions
Sirius satellite radio system
Stereo/CD system w/MP3/auxiliary audio connections - satellite ready
Swim platform w/ladder (full width)
Swim platform w/ladder (small port side)
Windshield washer - freshwater (starboard)

Canvas Options
Hardtop drop curtain
Hardtop front & side curtains



Advance 257

25' CENTER CONSOLE

Beam Amidships:	8'6"
Bridge Clearance:	7"
w/T-top:	8'5"
Center Line Length:	24'9"
Cockpit Depth:	27"
Cockpit Square Footage:	64 sq. ft.
Hull Draft:	20"
Maximum HP:	350
Outboard Shaft Length	
Single:	30"
Dual:	25"
Standard Fuel Capacity:	151 gal.
Transom Width:	7'10"
Weight w/o Engine:	4045 lb.

STANDARD FEATURES

Safety
Automatic bilge pump (2600 GPH)
Basic flotation
Bow rail - low profile 316 grade stainless steel
Cockpit toe rails
Console grab rail
Nonskid fiberglass liner
Self-bailing cockpit w/4 cockpit drains
Stainless steel through-hull fittings

Cockpit & Deck

100% hand laid hull & deck
Battery select switch
Bow lifting ring
Bow pulpit (includes high profile bow rail)
Convenience package - forward bolsters & forward platform cushions
Electronics flush mount kit
Head - portable
Head - portable w/deck pump out
Head - portable w/in-line macerator
Outrigger kit - 15-ft. radial T-top mounted (w/hardtop option only)
Rod storage - folding cabin rack (6)
Seating - deluxe helm chair II
Seating - foredeck cushions
Sirius satellite radio system
Stereo/CD system w/MP3/auxiliary audio connections - satellite ready
T-top w/radio box, radar flat, dome light, storage net, spreader light, rod holders (4) & outrigger plates

Canvas Options
T-top front & side curtains

Fuel capacity - 151-gallon tank
Heavy-duty gunwale molding
Hydraulic trim tabs w/indicator & retractor
Integrated outboard mounting system w/swim platform & ladder

International lighting
Livewell - 32-gallon aft insulated raw water livewell w/light, full column distribution inlet & ob drain (1100 GPH pump)
Rod holders (4)
Rod storage racks - horizontal (6)
Rubrail - high density PVC w/stainless steel insert
Seating - deluxe lean bar w/footrest, backrest, knife & pliers holders (2), tackle trays, lockable storage & rod holders (4)
Seating - fold away aft bench seat w/cushion
Spring line cleats
Stern eyes - heavy-duty 316 stainless steel
Storage - forward anchor locker w/rode storage
Storage - forward tackle trays
Transom door - fiberglass
Washdown - pressurized raw water w/hose
Water tank - 20-gallon freshwater

Console

Accessory outlet - 12V (2)
Console ventilator
Drink holders (2)
Head - lockable console w/stand up head area, storage shelves & hanging locker
Seating - molded forward console seat w/cushion
Steering - hydraulic tilt
Steering wheel - 316 grade stainless steel
Storage - lockable electronics box
Storage - under footrest
Storage nets
Windshield - Plexiglas windshield w/handrail

OPTIONAL FEATURES

Anchor windlass (must have bow pulpit)
Bow lifting ring
Bow pulpit (includes high profile bow rail)
Convenience package - forward bolsters & forward platform cushions
Electronics flush mount kit
Head - portable
Head - portable w/deck pump out
Head - portable w/in-line macerator
Outrigger kit - 15-ft. radial T-top mounted
Storage - under berth compartments (5)
Storage nets
Windows - opening windows w/screens (2)



Journey 258

25' WALKAROUND CABIN

Beam Amidships:	8'6"
Bridge Clearance:	6'6"
w/Hardtop:	8'8"
Center Line Length:	24'9"
Cockpit Depth:	27"
Cockpit Square Footage:	55 sq. ft.
Hull Draft:	20"
Maximum HP:	350
Outboard Shaft Length	
Single:	30"
Dual:	25"
Standard Fuel Capacity:	127 gal.
Transom Width:	7'10"
Weight w/o Engine:	4320 lb.

STANDARD FEATURES

Safety
2 automatic bilge pumps (total 2600 GPH)
Basic flotation
Bow rail - 316 grade stainless steel
Cockpit toe rails
Auxiliary fuel capacity - 41-gallon tank
Bow lifting ring
Bow pulpit
Cockpit bolsters
Hardtop w/radio box, storage net, spreader lights & side mounted rod holders (4)
Hardtop top mounted rod holders
Head - marine head w/macerator, 10-gallon holding tank & pump out
Head - portable
Head - portable w/deck pump out
Head - portable w/in-line macerator
Outrigger kit - 15-ft. radial hardtop mounted (w/hardtop option only)
Rod storage - folding cabin rack (4)
Sink
Storage - portable head compartment
Storage - under berth compartments (5)
Storage nets
Windows - opening windows w/screens (2)

Cabin

Berth - forward vee berth
Cabin light
Carpet
Forward hatch - low profile acrylic hatch w/screen
Lockable door w/screen & companionway hatch
Rod storage holders (4)
Sink
Storage - portable head compartment
Storage - under berth compartments (5)
Storage nets
Windows - opening windows w/screens (2)

Cockpit & Deck

100% hand laid hull & deck
Accessory outlet - 12V (2)
Battery select switch
Cockpit freshwater shower (recessed)
Cockpit lights - LED cockpit lighting under gunwales
Compass
Cutting board

Deck hardware - 316 grade stainless steel through-bolted
Drink holders (6)
Factory engine pre-rigging
Fish box - 158-qt. starboard insulated fish box w/ob drain
Footrest - helm & companion (adjustable)
Fuel capacity - 127-gallon tank
Heavy-duty gunwale molding
Hydraulic trim tabs w/indicator & retractor
Ice box - 40-qt. aft insulated ice box w/ob drain
Integrated outboard mounting system w/swim platform & ladder

International lighting
Livewell - 34-gallon port insulated raw water livewell w/light, full column distribution inlet & ob drain (1100 GPH pump)
Rod holders (6)
Rod storage racks - horizontal (6)
Rubrail - high density PVC w/stainless steel insert
Seating - deluxe helm & companion chairs
Seating - fold away aft bench seat w/cushion
Seating - port livewell cushion
Seating - starboard fish box cushion
Spring line cleats
Steering - hydraulic tilt
Steering wheel - 316 grade stainless steel
Stern eyes - heavy-duty 316 stainless steel
Storage - forward anchor locker w/rode storage
Storage - lockable electronics box
Storage - lockable storage under helm seat
Storage - tackle drawer under companion seat
Storage - transom mounted knife & pliers holder
Transom door - fiberglass
Washdown - pressurized raw water w/hose
Water tank - 10-gallon freshwater
Windshield - ventilated windshield
Windshield wiper (starboard)

OPTIONAL FEATURES

Anchor windlass (must have bow pulpit)
Auxiliary fuel capacity - 41-gallon tank
Bow lifting ring
Bow pulpit
Cockpit bolsters
Hardtop w/radio box, storage net, spreader lights & side mounted rod holders (4)
Hardtop top mounted rod holders
Head - marine head w/macerator, 10-gallon holding tank & pump out
Head - portable
Head - portable w/deck pump out
Head - portable w/in-line macerator
Outrigger kit - 15-ft. radial hardtop mounted (w/hardtop option only)
Rod storage - folding cabin rack (4)
Seating - deluxe helm chair II
Seating - foredeck cushions
Sirius satellite radio system
Stereo/CD system w/MP3/auxiliary audio connections - satellite ready
Windshield washer - freshwater (starboard)
Windshield wiper (port)

Canvas Options
Drop curtain (hardtop or vista top)
Hardtop front & side curtains
Vista top w/side curtains & boot



Chase 273

27' CENTER CONSOLE

Beam Amidships:	8'6"
Bridge Clearance:	6'9"
w/T-top:	8'3"
Center Line Length:	26'11"
Cockpit Depth:	27"
Cockpit Area:	65 sq. ft.
Hull Draft:	20"
Maximum HP:	500
Outboard Shaft Length	
Single:	30"
Dual:	25"
Standard Fuel Cap:	205 gal.
Transom Width:	7'10"
Weight w/o Engine:	4843 lb.

STANDARD FEATURES

Safety
2 automatic bilge pumps (2600 GPH)
Basic flotation
Bow rail - low profile 316 grade stainless steel
Cockpit toe rails
Nonskid fiberglass liner
Self-bailing cockpit w/4 cockpit drains
Stainless steel through-hull fittings

Cockpit & Deck

100% hand laid hull & deck
Anchor windlass wiring
Battery select switch
Cockpit bolsters
Cockpit freshwater shower (recessed)
Cockpit lights - LED cockpit lighting under gunwales
Compass
Cutting board
Deck hardware - 316 grade stainless steel through-bolted
Drink holders (4)
Factory engine pre-rigging
Fish box - 104-qt. port insulated fish box w/ob drain
Fish box - 104-qt. starboard insulated fish box w/ob drain
Fish box - 185-qt. aft insulated fish box w/ob drain
Forward bolsters
Fuel capacity - 205-gallon tank
Heavy-duty gunwale molding
Hydraulic trim tabs w/indicator & retractor

Integrated outboard mounting system w/swim platform & ladder
International lighting
Livewell - 32-gallon aft insulated raw water livewell w/light, full column distribution inlet & ob drain (1100 GPH pump)
Rod holders (4)
Rod storage - lockable horizontal storage for 6 rods
Rubrail - high density PVC w/stainless steel insert
Seating - deluxe lean bar w/footrest, backrest, tackle trays, lockable storage, 4 rod holders & removable 94-qt. cooler
Seating - fold away aft bench seat w/cushion
Seating - forward platform cushions
Spring line cleats
Stern eyes - heavy-duty 316 stainless steel
Storage - forward anchor locker w/rode storage
Transom door - fiberglass
Washdown - pressurized raw water w/hose
Water tank - 20-gallon freshwater

Console

Accessory outlet - 12V (2)
Console ventilator
Drink holders (2)
Head - lockable console w/stand up head area, sink, bulk storage & drawers
Seating - molded forward console seat w/cushion
Steering - hydraulic tilt
Steering wheel - 316 grade stainless steel
Storage - electro-mechanically operated electronics enclosure
Windshield - Plexiglas windshield w/handrail

OPTIONAL FEATURES

Anchor windlass
Bow lifting ring
Bow pulpit (includes high profile bow rail)
Casting platform insert
Casting platform insert cushions
Head - marine head w/electric flush (10-gallon)
Head - marine head w/macerator, 10-gallon holding tank & pump out
Head - portable
Head - portable w/deck pump out
Head - portable w/in-line macerator
Outrigger kit - 15-ft. radial T-top mounted (w/T-top option only)
Sirius satellite radio system
Stereo/CD system w/MP3/auxiliary audio connections - satellite ready
T-top w/radio box, radar flat, dome light, storage net, spreader light, rod holders (4) & outrigger plates

Canvas Options
T-top front & side curtains



Tournament 275

27' DUAL CONSOLE

Beam Amidships:	8'6"
Bridge Clearance:	6'3"
Bridge Clearance w/Hardtop:	8'5"
Center Line Length:	26'11"
Cockpit Depth:	27"
Cockpit Square Footage:	60 sq. ft.
Hull Draft:	20"
Maximum HP:	500
Outboard Shaft Length	
Single:	30"
Dual:	25"
Standard Fuel Capacity:	200 gal.
Transom Width:	7'10"
Weight w/o Engine:	4972 lb.

STANDARD FEATURES

Safety
2 automatic bilge pumps (2600 GPH)
Basic flotation
Bow rail - low profile 316 grade stainless steel
Cockpit toe rails
Nonskid fiberglass liner
Self-bailing cockpit w/4 cockpit drains
Stainless steel through-hull fittings

Cockpit & Deck

100% hand laid hull & deck
Accessory outlet - 12V (2)
Anchor windlass wiring
Battery select switch
Cockpit bolsters
Cockpit freshwater shower (recessed)
Cockpit lights - LED cockpit lighting under gunwales & forward seating area
Companion grab rail
Compass
Cutting board
Deck hardware - 316 grade stainless steel through-bolted
Drink holders (11)
Factory engine pre-rigging
Fish box - 88-qt. starboard insulated fish box w/ob drain
Fish box - 185-qt. aft insulated fish box w/ob drain
Footrest - helm
Forward bolsters
Fuel capacity - 200-gallon tank

Head - lockable console w/bulk storage
Hydraulic trim tabs w/indicator & retractor
Integrated outboard mounting system w/swim platform & ladder
International lighting
Rod holders (4)
Rod storage racks - horizontal (3)
Rubrail - high density PVC w/stainless steel insert

Seating - vertically & horizontally adjustable deluxe helm & companion chairs
Seating - fold away aft bench seat w/cushion
Seating - forward platform cushions
Spring line cleats
Steering - hydraulic tilt
Steering wheel - 316 grade stainless steel
Stereo/CD system w/2 remote controls - satellite ready
Stern eyes - heavy-duty 316 stainless steel
Storage - forward anchor locker w/rode storage
Storage - starboard console storage drawer
Storage - starboard lockable storage area
Transom door - fiberglass
Washdown - pressurized raw water w/hose
Water tank - 20-gallon freshwater
Windshield - walk-through windshield
Windshield wiper (starboard)

OPTIONAL FEATURES

Anchor windlass
Bow lifting ring
Cockpit table
Hardtop w/radio box, storage net & spreader lights
Hardtop top mounted rod holders
Head - marine head w/electric flush (10-gallon)
Head - marine head w/macerator, 10-gallon holding tank & pump out
Head - portable
Head - portable w/deck pump out
Head - portable w/in-line macerator
Livewell - 32-gallon aft insulated raw water livewell w/light, full column distribution inlet & ob drain (1100 GPH pump)
Sirius satellite radio system
Seating - electronically-operated extendable port sleeper seat
Ski pylon
Sun platform w/cushion
Wet bar w/electronically-operated helm lounge seat, sink, storage drawer & trash compartment

Canvas Options

Aft curtain
Bow cover
Hardtop front & side curtains
Hardtop aft curtain
Vista top w/front & side curtains (canvas available in ivory or navy)

Visit www.gradywhite.com for the very latest specifications, performance reports, magazine reviews, virtual tours, additional photos and more detailed information on every Grady-White model.



Express 330

33' EXPRESS CABIN

Beam Amidships:	11'7"
Bridge Clearance w/Hardtop:	9'10"
Center Line Length:	33'6"
Length Overall (w/pulpit):	35'10"
Cockpit Depth:	29"
Cockpit Square Footage:	80 sq. ft.
Hull Draft:	25"
Maximum HP:	700
Outboard Shaft Length:	25"
Standard Fuel Capacity:	350 gal.
Transom Width:	10'6"
Weight w/o Engines:	10,840 lb.

STANDARD FEATURES

Safety

2 automatic bilge pumps (total 3000 GPH)
Basic flotation
Bow rail - 316 grade stainless steel
Cockpit toe rails
Companion grab rail
Nonskid fiberglass liner
Self-bailing cockpit w/4 cockpit drains
Stainless steel through-hull fittings

Cabin

Accessory outlet - 12V
Air conditioning - 10,000 BTU
Berth - aft double berth
Berth - forward vee berth
Cabin lights
Flat screen 15" LCD TV w/DVD player & audio visual inputs
Forward hatch - low profile acrylic hatches w/retractable screen & shade (2)
Forward hatch curtains
Galley - port side galley w/sink & Corian® cutting board
Head - enclosed ventilated head area w/sink, shower, lamps, storage cabinet & Vacuflush® marine head w/10-gallon holding tank
Lockable door w/screen & companionway hatch
Microwave oven
Mirrors
Refrigerator
Rod storage racks
Stereo/CD system w/MP3/auxiliary audio connections - satellite ready

Storage - galley cabinets
Storage - under berth compartments
Storage nets
Stove - electric glass top
Teak & holly sole
Teak table
Water heater - 6-gallon, 120V
Water tank - 44-gallon freshwater

Cockpit & Deck

100% hand laid hull & deck
Accessory outlet - 12V (2)
Anchor windlass w/remote switches at helm & windlass
Batteries (4)

Battery charger system
Battery select switch
Bow pulpit w/roller
Cockpit bolsters
Cockpit freshwater shower (recessed)
Cockpit lights - LED cockpit lighting under gunwales
Cockpit lights - LED lighting at helm
Compass

Cooler - 56-qt. port helm seat cooler
Deck hardware - 316 grade stainless steel through-bolted
Dockside power w/galvanic isolator
Drink holders (8)
Factory engine pre-rigging
Fighting chair reinforcement
Fish box - 254-qt. aft insulated fish box w/ob drain
Footrest - helm (adjustable)

Fuel capacity - 350 gallons (150-gallon tank, 200-gallon tank)
Generator - 4KW diesel, 13-gallon fuel capacity
Hardtop w/radio box, storage net, spreader lights, rod holders (6), low profile acrylic hatch & canvas (canvas available in navy or ivory)

Heavy-duty gunwale molding
Hydraulic trim tabs w/indicator & retractator
Integrated outboard mounting system w/swim platform & ladder
International lighting
Livewell - 45-gallon starboard insulated raw water livewell w/light, full column distribution inlet & ob drain (1100 GPH pump)

Rigging station w/freshwater sink & pullout faucet
Rod holders - gunwale (4)
Rod storage racks - horizontal (4)
Rubrail - high density PVC w/stainless steel insert
Seating - fold away aft bench seat w/cushion
Seating - helm area surround seat
Seating - vertically & horizontally adjustable deluxe helm chair

Spring line cleats
Steering - hydraulic tilt
Steering wheel - 316 grade stainless steel
Stern eyes - heavy-duty 316 stainless steel
Storage - aft deck lift out box
Storage - electromechanically operated electronics enclosure
Storage - forward anchor locker w/rode storage
Storage - under helm area surround seating
Storage nets
Transom door - fiberglass
Washdown - pressurized raw water w/hose
Windshield - ventilated windshield
Windshield washer - freshwater
Windshield wiper

OPTIONAL FEATURES

Air conditioning - 12,000 BTU at helm
Bow thruster
Deluxe helm chair
Freezer - refrigerator/freezer fish box/cooler w/digitally controlled thermostat & ob drain
Outrigger kit - 15-ft. radial hardtop mounted
Outrigger kit - 24-ft. Lee Pro Series (lay out)
Steering - power assist (standard w/TF350 pkg)
Sirius satellite radio system



Canyon 336

33' CENTER CONSOLE

Beam Amidships:	11'7"
Bridge Clearance:	8'
w/T-Top:	9'
Center Line Length:	33'6"
Cockpit Depth:	29"
Cockpit Square Footage:	80 sq. ft.
Hull Draft:	25"
Maximum HP:	700
Outboard Shaft Length:	25"
Standard Fuel Capacity:	350 gal.
Transom Width:	10'6"
Weight w/o Engines:	9200 lb.

STANDARD FEATURES

Safety

2 automatic bilge pumps (total 3000 GPH)
Basic flotation
Bow rail - low profile 316 grade stainless steel
Cockpit toe rails
Console grab rail (2)
Nonskid fiberglass liner
Self-bailing cockpit w/4 cockpit drains
Stainless steel through-hull fittings

Cockpit & Deck

100% hand laid hull & deck
Anchor windlass w/remote switches at helm & windlass
Battery charger
Battery select switch
Cleats - pop-up (flush mount)
Cockpit bolsters
Cockpit freshwater shower (recessed)
Cockpit lights - LED cockpit lighting under gunwales
Cutting boards (2)
Deck hardware - 316 grade stainless steel through-bolted
Dockside power w/galvanic isolator
Drink holders (7)
Factory engine pre-rigging

Fish box - 165-qt. port & starboard insulated fish boxes w/ob drain
Fish box - 291-qt. aft insulated fish box w/ob drain
Forward bolsters
Fuel capacity - 350 gallons
Hydraulic trim tabs w/indicator & retractator
Integrated outboard mounting system w/swim platform & ladder
International lighting
Livewell - 45-gallon insulated raw water livewell w/light, full column distribution inlet & ob drain (1100 GPH pump)
Rigging station - lean bar station w/freshwater washdown, 104-qt. cooler, tackle drawers, bulk storage, rod holders (6) & holders for knife and pliers (2)
Rod storage - horizontal storage for 6 rods
Rubrail - high density PVC w/stainless steel insert
Seating - deluxe lean bar w/footrest, deluxe sliding chairs (3)
Seating - fold away aft bench seat w/cushion
Stern eyes - heavy-duty 316 stainless steel
Storage - aft transom drop in box
Storage - forward anchor locker w/rode storage
Storage nets
Transom door - fiberglass
Washdown - pressurized raw water w/hose (2)
Water tank - 44-gallon freshwater

Forward bolsters
Fuel capacity - 350 gallons
Hydraulic trim tabs w/indicator & retractator
Integrated outboard mounting system w/swim platform & ladder
International lighting
Livewell - 45-gallon insulated raw water livewell w/light, full column distribution inlet & ob drain (1100 GPH pump)
Rigging station - lean bar station w/freshwater washdown, 104-qt. cooler, tackle drawers, bulk storage, rod holders (6) & holders for knife and pliers (2)
Rod storage - horizontal storage for 6 rods
Rubrail - high density PVC w/stainless steel insert
Seating - deluxe lean bar w/footrest, deluxe sliding chairs (3)
Seating - fold away aft bench seat w/cushion
Stern eyes - heavy-duty 316 stainless steel
Storage - aft transom drop in box
Storage - forward anchor locker w/rode storage
Storage nets
Transom door - fiberglass
Washdown - pressurized raw water w/hose (2)
Water tank - 44-gallon freshwater

Console

Accessory outlet - 12V (2)
Berth
Compass
Console ventilator
Drink holders (3)
Head - lockable console w/stand up head area, shower, sink, bulk storage drawers, VacuFlush® head, 10-gallon holding tank & pump out, bulk storage

Rod storage - vertical lockable storage for 6 rods
Seating - molded forward console seat w/cushion (3)

Steering - hydraulic tilt
Steering wheel - 316 grade stainless steel
Stereo/CD system w/MP3/auxiliary audio connections - satellite ready
Storage - electromechanically operated electronics enclosure
Storage - lockable acrylic console door
Storage pockets (3)
Storage - under footrest
Window - opening window w/screen
Windshield - glass windshield
Windshield wiper

OPTIONAL FEATURES

Air conditioning in console w/2 outlets at helm (5,000 BTU)
Bow thruster
Casting platform insert
Casting platform insert cushions
Freezer - refrigerator/freezer fish box w/digitally controlled thermostat & ob drain
Generator - 4kw diesel, 12-gal. fuel capacity
Livewell - 26-gal. livewell (replaces lean bar cooler)
Microwave
Outrigger kit - 15-ft. radial T-top mounted (w/T-top option only)
Sirius satellite radio system
Steering - power assist (standard w/TF350 package)
T-top (fiberglass) w/radio box, antenna flats, dome light, storage net, fore/aft spreader lights & rod holders (5) & stereo speakers (2)
Water heater (6 gallons)

Canvas Options

T-top front & side curtains (canvas available in ivory or navy)



Express 360

36' EXPRESS CABIN

Beam Amidships:	13'2"
Bridge Clearance w/Hardtop:	10'6"
Center Line Length:	36'7"
Length Overall (w/pulpit):	39'3"
Cockpit Depth:	28"
Cockpit Square Footage:	96 sq. ft.
Hull Draft:	29"
Maximum HP:	1050
Outboard Shaft Length:	
Port & Starboard Engines:	25"
Center Engine:	30"
Standard Fuel Capacity:	370 gal.
Freshwater Capacity:	65 gal.
Transom Width:	11'4"
Weight w/o Engines:	14,919 lb.

STANDARD FEATURES

Safety

2 automatic bilge pumps (total 3000 GPH)
Basic flotation
Bow rail - 316 grade stainless steel
Cockpit toe rails
Companion hand rails
Fire extinguisher mounting equipment
Nonskid fiberglass surfaces
Self-bailing cockpit w/4 cockpit drains
Stainless steel through-hull fittings

Cabin

Accessory outlet - 12V
Accessory outlet - 110V duplex outlet (3)
Air conditioning - 16,000 BTU
Berth - aft double berth w/mattress
Berth - convertible dinette area
Berth - forward vee berth w/mattress
Cabin lights - variable lighting, reading lamps & illuminated etched glass in teak bulkhead
Cable TV inlet
Corian® shelf w/drink holders behind dinette
Flat screen 15" LCD TV w/DVD player & audio visual inputs
Forward hatch - low profile acrylic hatches w/retractable screen & shade (2)
Lockable sliding door w/separate screen door
Mirror

Rod storage racks - aft berth (6)
Seating - premium vinyl surface dinette surround cushions
Sirius satellite service
Skylight
Stereo/CD system - MP3/auxiliary audio connections
Storage - dinette storage cabinet w/teak tambour door
Storage - molded-in fiberglass under berth compartments (3)
Storage - molded-in fiberglass storage under dinette
Storage - shelves
Storage - stacked teak drawers under forward berth (2)
Teak cedar-lined pullout hanging closet
Teak dinette table w/adjustable stainless steel base (seats 4)
Teak & holly sole
Water heater - 11-gallon, 120V
Water tank - 54-gallon freshwater
Water level indicator gauge

Galley

Electric glass top stove w/2 burners
Freezer drawer w/ice maker
Microwave oven - 1.1 cu. ft. convection microwave oven - 120 Volt, 60 Hz
Refrigerator drawer
Stainless steel sinks w/Corian® counter surface (2)
Storage - fiberglass cabinet w/teak & tambour doors over galley
Storage - premium teak drawers & doors under galley
Teak pullout trash container area

Head

Enclosed ventilated head area
Full length mirror located on door
Shower area w/deluxe curtain & teak floor drain cover
Sink w/Corian® counter surface
Storage - fiberglass cabinet below sink
Storage - teak shelves (2)
VacuFlush® marine head w/18-gallon holding tank
Vanity w/mirror & lamps

Cockpit & Deck

100% hand laid hull & deck
Accessory outlet - 12V (2)
Accessory outlet - 110V outlet
Air conditioning - 16,000 BTU at helm
Anchor windlass w/chain & rode w/remote switches at helm & windlass
Bow pulpit w/roller
Bow thruster - Lewmar 185TT 4.5 KW/6.0 HP
Cockpit bolsters
Cockpit freshwater shower (recessed) (2)
Cockpit lights - LED cockpit lighting under gunwales
Cockpit lights - LED lighting at helm
Compass w/light
Cooler - 55-qt. port side refrigerator/freezer cooler w/digitally controlled thermostat & ob drain

Deck cleats - 316 stainless steel 10-inch through-bolted (6)
Deck hardware - 316 grade stainless steel through-bolted
Dockside water inlet
Drink holders (10)
Fighting chair reinforcement area
Fish box - 291-qt. aft refrigerator/freezer fish box w/digitally controlled thermostat & ob drain

Footrest - helm (adjustable)
Fuel capacity - 370 gallons (190-gallon tank, 180-gallon tank)
Generator - 8 KW diesel, 23-gallon fuel capacity
Hardtop w/storage net, recessed spreader lights, recessed stereo speakers, rod holders (6 horizontal, 6 vertical), 2 low profile acrylic hatches & canvas (canvas available in navy or ivory)
Hydraulic trim tabs (recessed) w/indicator & retractator

Integrated outboard mounting system w/swim platform & stainless steel telescoping ladder
International lighting
Livewell - 48-gallon starboard insulated raw water livewell w/light, full column distribution inlet & ob drain (1100 GPH pump)

Rigging station w/freshwater sink, pullout faucet, insulated bait box, knife/pliers/bait rigs holder & lockable drawers (4)
Rod holders - gunwale (4)
Rod storage racks - below gunwale (6)
Rubrail - high density PVC w/stainless steel insert
Seating - patented fold away aft bench seat w/cushion
Seating - port lounge seat w/enclosed storage below

Seating - starboard lounge seat w/convertible configurations & hideaway folding table
Seating - vertically & horizontally adjustable deluxe helm chair
Steering - hydraulic tilt w/Teleflex power assist
Steering wheel - 15-in. 316 grade stainless steel
Stern eyes - heavy-duty 316 stainless steel
Storage - chart storage at helm
Storage - drawers under starboard seat (2)
Storage - electromechanically operated electronics enclosure

Storage - fender storage
Storage - forward anchor locker w/rode storage
Storage - removable transom storage bin
Storage - under helm footrest
Storage net
Transom door - fiberglass
Washdown - pressurized raw water w/hose & remote switch
Windshield - heavy duty welded aluminum windshield w/electromechanically operated center vent
Windshield washers - freshwater (3)
Windshield wipers - self parking w/heavy-duty pantograph arms w/intermittent & separate controls (3)

Electrical

Batteries (5)
Battery charger system (2)
Battery select switch (3)
Dockside power w/galvanic isolator & 30 amp service outlets w/shore power cords (2)
Factory engine pre-rigging
Teleflex electronic shifter throttles

OPTIONAL FEATURES

Outrigger kit - 15-ft. radial hardtop mounted
Outrigger kit - 24-ft. Lee Pro Series (lay out)

Grady-Built for customer satisfaction with quality, reliability, safety and long term value.

Anchor locker with rode storage

Safety glass windshields

Grab rails are at your fingertips at the helm, in the cockpit, walkaround area and when you climb back onboard after a swim.

Solid 100% hand laid hulls and decks provide uniform laminate structure, strength and durability.

Through-bolted upright rod holders are chrome-over-bronze.

Stainless steel screws and blindside fasteners join the hull and liners to the deck with silicon and a powerful bonding adhesive developed for the aerospace industry.

Liner is bonded to the stringer system for long lasting strength.

All Grady-Whites have foam sprayed into the hull for level (models 180, 185) or basic flotation, even though not required in boats over 20 feet. This foam also adds strength, thermal insulation and deadens sounds. There is no boat brand with better flotation properties.

Proven no-rot stringer system is encapsulated in resin and fiberglassed to the hull.

Protected rigging with factory installed PVC tubing

Through-bolted 316 stainless steel hardware is secured with locking nuts.

Yamaha engine pre-rigging is installed at the factory and custom fitted to your boat.

You're in command. Boat Smart from the Start! Take a boating education course, and get a vessel safety check for your boat. For more information, contact: U.S. Coast Guard Auxiliary 877-875-6296/800-368-5647 or www.cgaux.org and U.S. Power Squadrons 888-367-8777 or www.usps.org.

\$ 5.00 ©2007 Grady-White Boats, Inc. • Grady-White Boats, P.O. Box 1527, Greenville, NC 27835 (252) 752-2111 www.gradywhite.com
Grady-White Boats, Inc. reserves the right to discontinue models, or change prices, specifications, materials, equipment, colors or designs at any time without incurring obligation. Weight and dimensions of models are approximate and may vary. Thanks to: Jerry Imber Photography; Ray Matthews Photography; Bruce Miller Photography; Chip Henderson Photography; Jason Mills, Dewane Frutiger/ASAP Photography; Josh Temple/Prime Time Adventures; and especially to Grady-White owners everywhere.

Double through bolting on threshold of cabin

Adjustable seats have integrated hand holds.

Storage is engineered for functionality. We aim to ensure that Grady-Whites have the most storage of any boat in their category.

Insulated fish boxes and ice boxes are above the waterline and drain overboard, never into the bilge. Gutter systems are built into all exterior storage spaces.

Nonskid true self-bailing cockpit directs water overboard whether at rest or underway. All scuppers drain overboard. Inspection ports are watertight. All Grady-Whites have automatic bilge pumps, with two pumps on most models over 20 feet. Our dedication to self-bailing cockpit integrity is unparalleled.

Toe rails secure your feet when you lean over the side.

Weather resistant polyethylene rod racks

Heavy-duty fiberglass transom door is not just for big fish, but adds easy access and safety too. Solid, 316 stainless transom door hardware is highlighted by a destroyer-sized latch with a positive locking mechanism for added safety.

Swim ladder is designed in every detail for ease of boarding and is super strong 316 stainless steel for safety.

Aluminum transom brace is bonded to the top of outboard transoms, which reinforces transom strength and distributes motor torque. On integrated bracket models, the brace is through bolted to the longitudinal stringer system.



The NMMA Certified label on a Grady-White boat is your proof it meets, and often exceeds, industry quality and safety standards.

