

# 2004 GRADY-WHITE





**WE ARE SO PLEASED** that you are considering a Grady-White boat! This model year marks the company's 45TH season, and

our passion for boat building grows ever stronger as our boats continue to delight so many satisfied customers.

The seaworthy performance of our boats is legendary. Ask our boat owners why they bought their Grady. You'll hear

the words, "Quality. Reliability. Performance. Lasting value." By nearly every measure, in multiple national studies conducted in our industry during the past several years, Grady-White Boats has been ranked highest in customer satisfaction for our product category.

How do we achieve such great third-party recognitions? We spend a lot of time with our customers, understanding how they use their boats and, most importantly, truly listening to suggestions on how we can make their experiences even better. Our dealers listen, too. They are held to the highest standards of customer satisfaction in the industry. Our management team reads every single owner survey. The entire Grady-White organization is dedicated—we believe to the greatest degree in our industry—to achieving the goal of your complete satisfaction. And the added benefit of all this customer contact is that along the way we make many great Grady friends! What could be better?

Happy Boating!

*Eddie Smith, Jr.*

EDDIE SMITH, CHAIRMAN & CEO

*Kris Carroll*

KRIS CARROLL, PRESIDENT

# The Grady Life

A celebration of great times on the water and the superbly engineered boats that help make them happen!

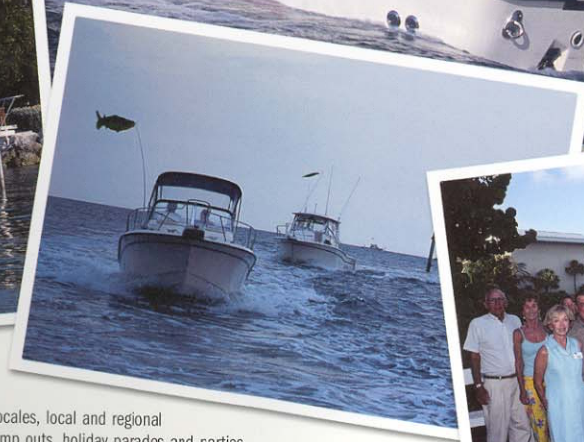
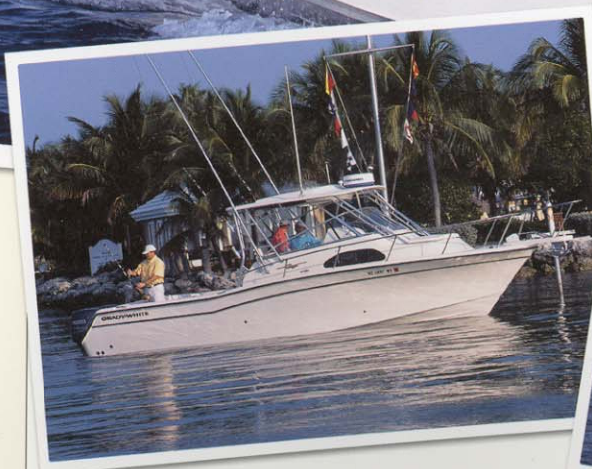
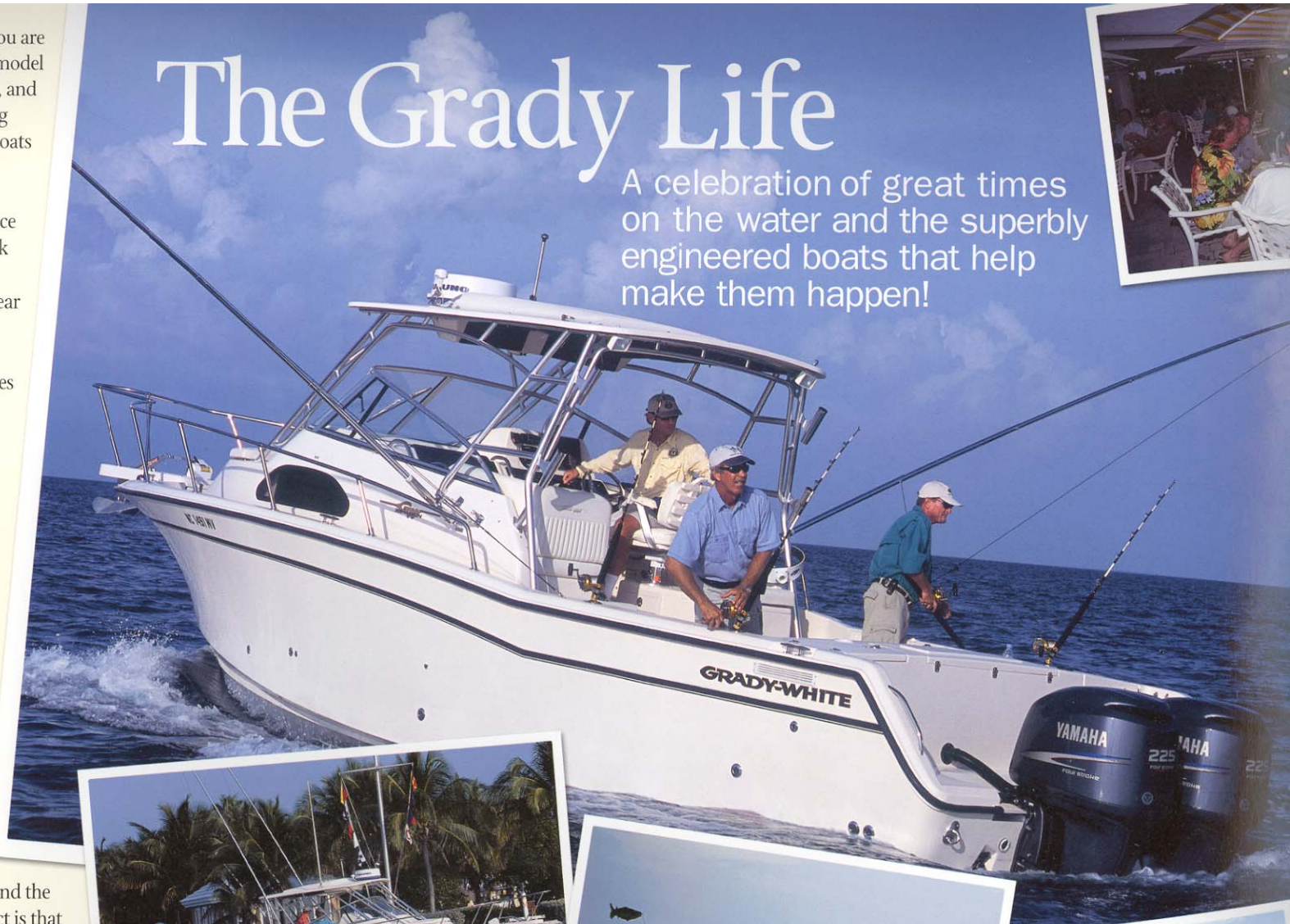

Organized fishing tournaments, day trips, overnight cruises, trips to exotic locales, local and regional get-togethers, clean ups, conservation projects, "take a kid fishing" events, camp outs, holiday parades and parties are among the activities that many Grady-White owners, dealerships and Grady Clubs enjoy. Join the fun!





## THE GRADY-WHITE DIFFERENCE

Grady-White is committed to building relationships that are as enduring as our boats. When you bring your family or group for a plant tour, you'll enjoy seeing how your boat is built by our craftsmen. When you note the pride and meticulous detailing involved in production, you'll be reassured of the reasons you got the Grady!

Your dealership is really the key to your boating satisfaction. Grady-White dealers have learned to listen closely to you, and they have the product knowledge to help you select the model, rigging and accessories that are best suited for your boating activities and expectations. They know that happy owners are the key to their success. Our dealer network can be good at anticipating your needs, you'll think they have ESP—and they do! Their excellence is partly based on training in execution, Sweating the details, and Passion (ESP).

As hard as we work to please you, we're sure to have a lot of FUN! Grady-White dealerships are a big part of The Grady-White experience, sponsoring tournaments and events enjoyed by the whole family. This past year we held the first National Owners' Rendezvous where people from all over

the country, including the Grady-White management team, gathered for a great get-together. All these occasions give boat owners the opportunity to share boating experiences, and provide us the chance to laugh and play alongside our customers. Ask about Grady-White Owners' Clubs and get-togethers in your area. You'll find your fellow Grady owners to be a great source of camaraderie and of reliable information...not to mention a lot of fun!

## AT GRADY-WHITE QUALITY BEGINS WITH THE CUSTOMER... CUSTOMER-IZATION!

The design, detail and dependability of every Grady-White are carefully engineered through a process of Grady owner input and review that we refer to as customer-ization. We combine superior naval architecture with what we learn from our customers about their boating preferences to create a full 20-model line of superbly engineered offshore sportfishing boats. There's a center con-



sole, dual console or cabin model just right for you and your family's boating style whether that's serious sportfishing, casual fishing or cruising, or family fun.

Whenever and wherever we have the opportunity—at boat shows, at dealer tournaments and other events, on the docks, out on the water, and here at the plant when you visit—we invite your input about what products and product features you like, and where you see room for improvement.

## VERSATILE NEW BOAT MODELS FOR 2004!

Versatility is the byword for what's new in model year 2004, and the best example is Grady-White's dual console *Tournament* series, our next generation designs for a new generation of Grady-White boaters! These are terrific family fun boats, packing our big boats' features into smaller boat packages for the greatest values on the water. All of our dual consoles provide wide open bow seating and access. Joining the popular 22' *Tournament 225* introduced for 2003 are the brand new 18' *Tournament 185* and 20' *Tournament 205*. These are also great fishing boats—particularly the 205 and 225—with large and stable bow areas, livewell options, easy flow and sure movement around the boat, and abundant

rod storage. Plus, Grady-White's seaworthiness and ride will convince even the hardcore sportsman that fishing function in our *Tournament* models is as great as that of similar-sized center consoles. The

dry storage capacity exceeds many bigger boats for all the tackle, toys and beach gear the family brings along. The optional ski pylon for the 185 and 205 is a totally new feature available for serious waterskiing and is loads of fun for other water toys, too. The *Tournament* hull designs and weight distribution are built to take advantage of Yamaha HPDI and 4-stroke engine technology for amazing performance. And the 205 and 225 feature lockable head compartments in the port console, making all-day outings a lot more comfortable for the whole family.

Totally redesigned to turn heads is our 2004 *Marlin 300* walkaround cabin model. From stem to stern, from the new bow pulpit to the super-sturdy new swim ladder, you'll see impressive differences. At the transom you'll find our signature fold away aft bench seat, a freshwater shower, a 290-quart insulated fish box, and a battlewagon-worthy transom door. New hardware, including latches for box tops, speaks quality right out loud. The helm is detailed with an area for optional flush-mounted electronics, and with a heavy-duty new steering wheel. The new *Marlin's* cabin is strikingly handsome, inspired by the stylish appointments found on the successful *Express 330*, including teak and holly flooring plus a deep stainless sink and a Corian® cutting surface in the galley. New fabrics brighten the entire cabin, and an optional entertainment center including a flatscreen TV with DVD player and a stereo/CD with remote system add to live aboard amenities. The new *Marlin* is one nice package!

## WE'RE HERE FOR THE LONG-TERM

Our company's private ownership and long-term leadership have allowed our craftsmen to concentrate exclusively on building the best boats. Our limited production philosophy furthers our attention to detail. From our family to yours, we build boats so you can build memories. Get the Grady!

**Versatility!** Grady-White presents the new *Tournament* series dual console models. Top to bottom: the *Tournament 185*, the 205, and the 225.

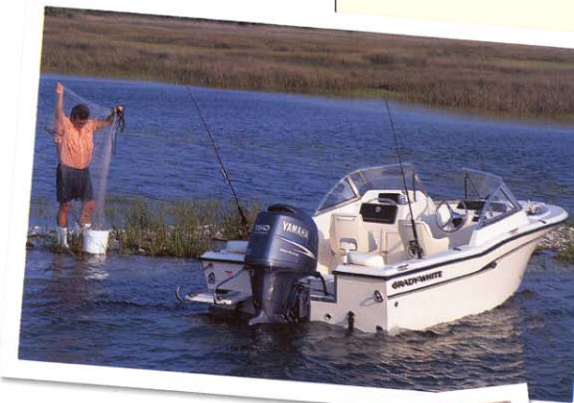



# Grady-Built boats

are engineered above all for quality, reliability, performance and enduring value.

## A LEGACY OF PRODUCT INTEGRITY AND LONG LASTING VALUE

Quite simply, there is no other sportfishing boat built like a Grady-White. Our boats are products of North Carolina saltwater heritage, and superbly engineered by a design team with extensive recreational fishing experience. We overbuild safety and security into our



boats that we hope owners never have to put to the test.



Grady-White was one of the first manufacturers to be Marine Industry

Certified by the National Marine Manufacturers Association and the Marine Retailers Association of America for your assurance of the highest quality building standards.

Grady-Built boats use the finest materials, laboratory and field proven for function and durability. We stress test our laminates to make sure they are strong, reliable and safe over the long haul. Our 316 grade stainless steel hardware contains nickel, chromium and molybdenum for superior strength and ability to withstand a saltwater environment. Chrome-over-bronze through-hull fittings are tough and durable, and hoses below the waterline are double clamped for an extra measure of quality and safety. The underside of fish and ice box lids are resin transfer molded (RTM) to create a smooth surface on the top and bottom of the lid, and is easy to clean. Polyethylene trim work and toe rails are extremely durable and need very low maintenance.

Our engineers really maximize storage space because our customers are always

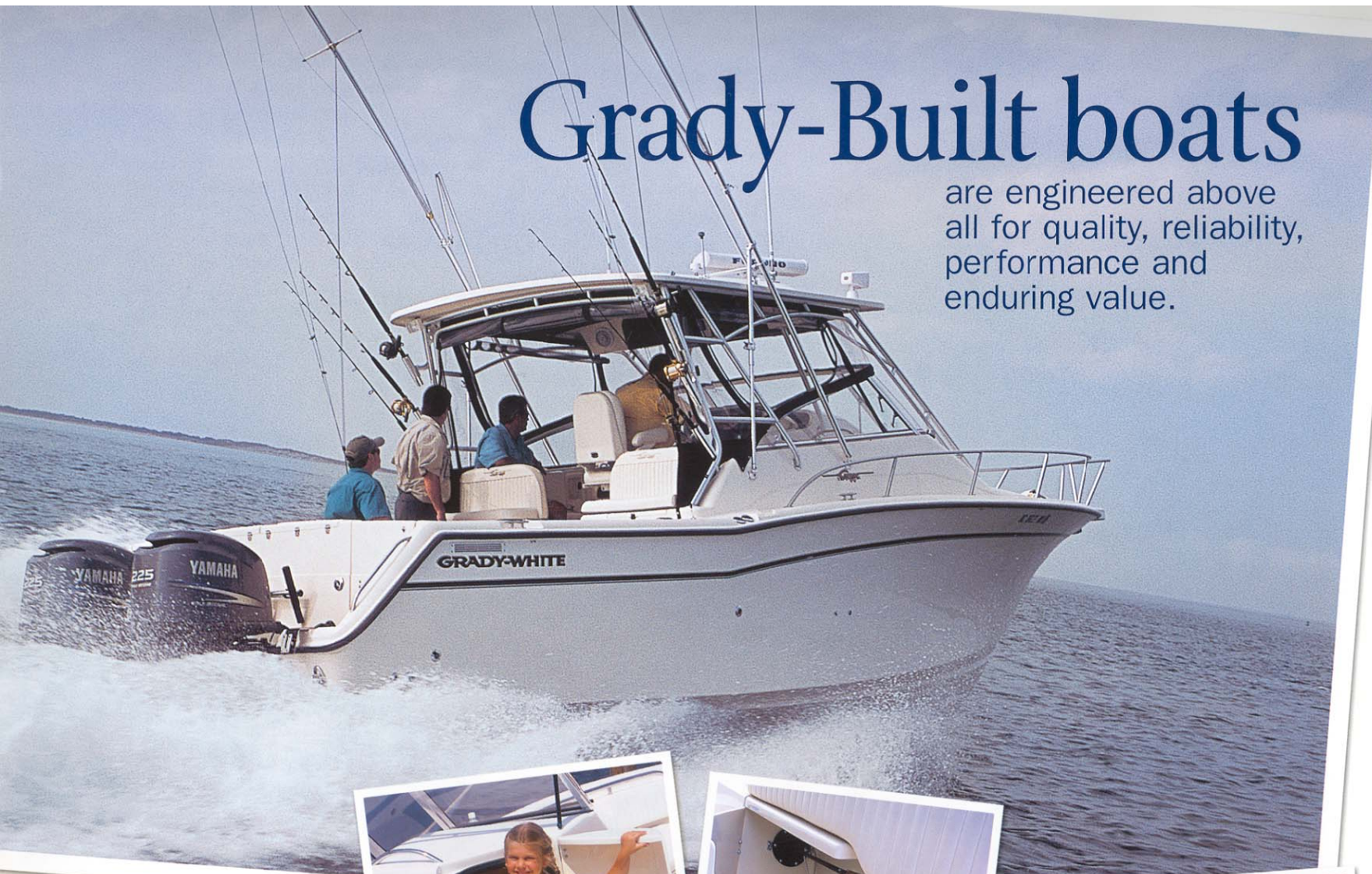





asking for more, so there's a place for everything on a Grady-White. There is storage under the berths, in deck areas, under seats, at the helm and companion seats, in the consoles—even under the hardtops with our innovative net storage. Our fish boxes are big and wide open, and electronics have plenty of room. Rod holders are everywhere (as are our big-enough-to-hold-the-drink-and-the-coolie drink holders) and tackle drawers and boxes make gear quick to locate and use. We've even fit head compartments into the consoles of every *Tournament* and center console model over 20 feet.

## PRODUCTS AND PEOPLE YOU CAN ABSOLUTELY RELY ON

Sound structural integrity is the basis of a tough, long lasting boat that retains top resale value when it is time to move up to a new Grady. Every Grady-White hull is built by a process of hand laid fiberglass that ensures better glass-to-resin ratios and thicker laminates for a stronger boat. All Grady-White boats have self-bailing

cockpits, with all decks and boxes draining directly overboard by gravity—not into a bilge or sump. We through-bolt our 5/16" aluminum braced transom to our never-rot stringers and encapsulate them in resin, then fiberglass them to the hull for exceptional strength.

You will not find a boat brand with greater certified flotation qualities than a Grady-White, period. Each of our boats is absolutely unsinkable. Though not required for boats over 20 feet, each and every Grady-White is closed cell foam filled with more than enough material to keep the boat, its motor, equipment and

specified number of passengers afloat. The ABYC (American Boating and Yachting Council) has even issued a tag made especially for Grady-White for our boats over 26 feet to signify that these models provide basic flotation for buoyancy in the unlikely event of swamping.

We construct such safety and security into our boats that even a first time boater feels confident aboard a Grady. Throughout every model you'll find through-bolted handholds and superior sure-grip nonskid surfaces. There are safety glass windshields, high interior gunwales, and wide walkarounds. Even all those drink holders are a safety device ensuring fewer spills of slippery liquids.

Our dealers and customer relations associates are as reliable as our boats.



SeaV<sup>2</sup> chines knock down spray for a drier ride. Notice three distinct waves when the boat is on plane. That's a SeaV<sup>2</sup> hallmark.

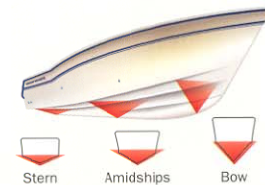

Grady's exclusive SeaV<sup>2</sup> hull is like a series of wedges: flatter aft for stability at rest or trolling, and sharper at the bow for sea-cutting power at speed.

Grady-White's dealer network is structured specifically for the purpose of serving our customers better. We place great emphasis on dealer Customer Satisfaction Index scores as rated by you the customer. There is always a channel of communication open to us by telephone or via the Internet at [custserv@gradywhite.com](mailto:custserv@gradywhite.com). Our representatives are approachable and knowledgeable, and intent on keeping you on the water and in a Grady.

## WE BUILD GREAT BOATS SO YOU CAN BUILD GREAT MEMORIES!

Every one of our hulls is a Grady-White SeaV<sup>2</sup> exclusive design by C. Raymond Hunt Associates, the originators of the modern deep vee. A SeaV<sup>2</sup> vee has a continuously sharper deadrise, with the effect of cutting through seas for a much softer ride. The strakes and chines are designed to knock down spray and keep it out of the cockpit, so the ride is drier as well. The hull has a tremendous tracking ability, even in quartering seas, so the boat moves through the water with more efficiency, providing greater performance. Before you buy, you simply must compare the Grady-White ride to other boats you may be considering. When you compare boats of similar length, in any weather and in any water, you will see that the ride

on a Grady-White boat is clearly superior.

A Grady-White is a true fishing machine, built by fishermen with a commitment to the best sportsmanship. Their know-how yields superior function: wide open cockpits, huge insulated fish boxes, livewell systems that keep bait alive, good cockpit depth for sure-footed stand up fishing, and solid fiberglass transom doors so you can lean into a fish. Many of these fishing features double as great amenities for cruising!

These design features along with our superior quality composition make for long-lived and easier to maintain boats. There are many Gradys decades old whose proud owners still enjoy great times on the water. Our long lasting boats really keep their resale value, too. Given the longevity and durability of such well crafted boats, your long term cost of ownership is actually much less with a Grady-White. That's one reason why we have so many repeat customers.

Make a Grady-White a part of your future, and a part of your family memories. Our complete selection of models and details about their features are shown in this catalog, and can be viewed by logging on to [www.gradywhite.com](http://www.gradywhite.com). There you can find the name of a Grady-White dealer nearest you. Visit them, and start enjoying The Grady Life!







GRADY-WHITE

YAMAHA

150





"MY HUSBAND LIKES HIS GRADY SO MUCH, he bought the 180 for the girls and me. We love it! We feel safe and secure every time we set out on the ocean." —Gail Zamaitis, Falmouth, MA, SPORTSMAN OWNER

18' CENTER CONSOLE

# SPORTSMAN 180

SPORTSMAN 180

- Beam Amidships: 7'5"
- Bridge Clearance: 5'7"
- Center Line Length: 17'10"
- Cockpit Depth: 22"
- Cockpit Square Footage: 48 sq. ft.
- Hull Draft: 14"
- Maximum HP: 150
- Outboard Shaft Length: 25"
- Standard Fuel Capacity: 60 gal.
- Transom Width: 7'2"
- Weight w/o Engine: 1800 lb.

## STANDARD FEATURES

### Safety

- Automatic bilge pump (1250 GPH)
- Bow rail - low profile 316 grade stainless steel
- Chrome-over-bronze through-hull fittings
- Cockpit toe rails
- Console grab rail
- Level flotation
- Nonskid fiberglass liner
- Self-bailing cockpit w/2 cockpit drains

### Cockpit & Deck

- 100% hand laid hull & deck
- Casting platform (raised)

- Deck hardware - 316 grade stainless steel through-bolted
- Drink holders (2)
- Fish box - 89-qt. insulated fish box/storage area w/ob drain
- Fuel capacity - 60-gallon tank
- Heavy-duty gunwale molding
- International lighting
- Rod holders (4)
- Rod storage racks - horizontal (4)
- Seating - bench seat w/reversible back
- Seating - aft seats (2)
- Stern eyes
- Storage - aft rigging compartments (2)
- Storage - forward anchor locker w/rope storage

### Console

- Accessory outlet - 12V
- Cellular phone holder
- Fish box - 45-qt. forward insulated fish box w/ob drain
- Footrest
- Rod storage holders - vertical (4)
- Seating - forward console seat

- Steering - no-feedback mechanical
- Steering wheel - 316 grade stainless steel
- Storage - lockable console storage
- Storage - lockable electronics box
- Storage net
- Windshield - Plexiglas windshield w/handrail

## OPTIONAL FEATURES

- Battery select switch w/extra battery
- Bow lifting ring
- Cockpit shower w/10-gallon freshwater tank
- High bow rail
- Hydraulic trim tabs
- Livewell - 11-gallon insulated raw water livewell
- Seating - forward platform cushions
- Steering - hydraulic (required w/4-stroke engine)
- Steering - tilt
- Swim platform w/ladder
- Washdown - pressurized raw water w/hose

## Canvas Options

- Bimini top w/boot
- Console cover

## CUSTOMER-IZATION

## THE "LITTLE BIG BOAT"

Big hardware. Big cockpit. A big, roomy helm station. A roomy, easy-to-get-to anchor locker, just like its big brothers. Large fish boxes and storage. As an Islamorada, FL, captain tells us, "Your Sportsman 180 is a 'little big boat.' It provides a feeling of confidence from the helm that is so much better than many boats nearly twice its size."

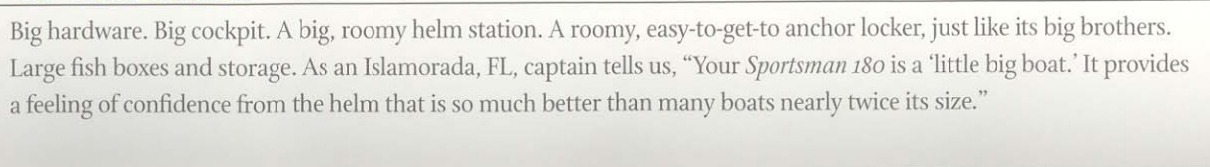

Console with lockable storage and electronics box



Bow casting platform



Bow fish box

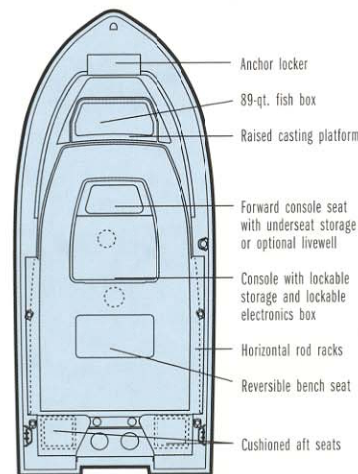

Forward console with seating and bow anchor locker





YAMAHA

150

FOUR STROKE

GRADY-WHITE

1875



RPOSE BOAT. FISH, SKI, SWIM on the lake, river, sound or inshore...especially good with Grady-White quality in a fun family package...great ride, too. The swim platform and re especially nice for the young ones." —Jay Tyson, Winterville, NC, Grady-White owner

18' DUAL CONSOLE

# TOURNAMENT 185



Length: 17'10"  
 Beam: 7'5"  
 Depth: 21"  
 Footage: 39 sq. ft.

Capacity: 60 gal.  
 Weight: 2250 lb.

## FEATURES

1250 (GPH)  
 316 grade stainless steel through-hull fittings  
 2 cockpit drains  
 1/2 deck

Deck hardware - 316 grade stainless steel through-bolted  
 Drink holders (9)  
 Fuel capacity - 60-gallon tank  
 Heavy-duty gunwale molding  
 Ice box - 48-qt. aft insulated ice box w/ob drain  
 Ice box - 38-qt. starboard bow insulated ice box w/ob drain  
 International lighting  
 Rod holders (2)  
 Rod storage racks - horizontal (4)  
 Seating - aft seats (2)  
 Seating - bow cushions  
 Seating - helm & companion pedestal chairs  
 Spring line cleats  
 Steering - no-feedback mechanical  
 Steering wheel - 316 grade stainless steel  
 Stern eyes  
 Storage - forward anchor locker w/rope storage  
 Storage - lockable console storage compartments (2)  
 Storage - lockable glove box  
 Storage - port bow seat compartment  
 Windshield - walk-through windshield  
 Windshield wiper (starboard)

## OPTIONAL FEATURES

Battery select switch  
 Bow lifting ring  
 Cockpit bolsters  
 Cockpit shower w/10-gallon freshwater tank  
 Forward bolsters  
 Hydraulic trim tabs  
 Livewell - 12-gallon insulated raw water livewell  
 Rod holders (2)  
 Seating - port sleeper seat  
 Ski pylon  
 Steering - hydraulic (required w/4-stroke engine)  
 Steering - tilt  
 Stereo/CD system  
 Sun platform w/cushion  
 Swim platform w/ladder  
 Washdown - pressurized raw water w/hose

## Canvas Options

Aft curtain  
 Bow cover  
 Vista top & side curtains w/boot

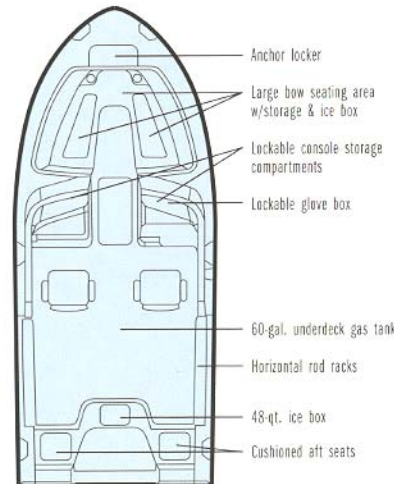

Helm station



Bow seating with optional forward bolsters



Port console storage



Starboard console storage

TOURNAMENT 185

## PERSONALIZATION



## AN OPTIONAL SKI PYLON (AND MORE!) FOR FAMILY FUN

"We love to fish, and we also enjoy tubing, skiing, picnicking—all kinds of family fun!" Familiar words to us at Grady-White. Fact is, owners want great boating memories plus quality, safety, reliability and performance. The optional ski pylon (which stows nicely in our room-for-all-the-toys compartments) is one example of what makes days on the water so special.







## TOURNAMENT 205

"THE MOST PRACTICAL DESIGN WE'VE SEEN, SO VERSATILE, GOOD FOR FISHING, TOO. THERE'S SEATING FOR UP TO EIGHT INCLUDING ROOMY FORWARD SEATING. CLEANS UP QUICK! AND A GOOD SURPRISE...THE ENCLOSED HEAD! EVERY INCH A GRADY...THE BEST 20-FOOTER AROUND!"—Mary Tyson, Winterville, NC Grady-White owner

- Beam Amidships: 8'1"
- Bridge Clearance: 5'7"
- Center Line Length: 20'4"
- Cockpit Depth: 25"
- Cockpit Square Footage: 49 sq. ft.
- Hull Draft: 14"
- Maximum HP: 230
- Outboard Shaft Length: 25"
- Standard Fuel Capacity: 82 gal.
- Transom Width: 7'10"
- Weight w/o Engine: 2810 lb.



## STANDARD FEATURES

## Safety

- Automatic bilge pump (1250 GPH)
- Basic flotation
- Bow rail - low profile 316 grade stainless steel
- Chrome-over-bronze through-hull fittings
- Cockpit toe rails
- Companion grab rail
- Nonskid fiberglass liner
- Self-bailing cockpit w/2 cockpit drains

## Cockpit &amp; Deck

- 100% hand laid hull & deck
- Accessory outlet - 12V
- Battery select switch
- Cockpit lights
- Compass
- Deck hardware - 316 grade stainless steel through-bolted
- Drink holders (8)
- Fish box - 64-qt. aft deck insulated fish box w/ob drain
- Fish box - 83-qt. starboard bow insulated fish box w/ob drain
- Fuel capacity - 82-gallon tank
- Head - lockable console head area w/storage nets
- Heavy-duty gunwale molding

- International lighting
- Rod holders (4)
- Rod storage racks - horizontal (6)
- Seating - aft seats (2)
- Seating - bow cushions
- Seating - helm & companion pedestal chairs
- Spring line cleats
- Steering - no-feedback mechanical
- Steering wheel - 316 grade stainless steel
- Stern eyes
- Storage - forward anchor locker w/rope storage
- Storage - lockable console compartment
- Storage - lockable glove box
- Storage - port bow seat compartment
- Windshield - walk-through windshield
- Windshield wiper (starboard)
- Seating - port sleeper seat
- Ski pylon
- Steering - hydraulic (required w/4-stroke engine)
- Steering - tilt
- Stereo/CD system
- Sun platform w/cushion
- Swim platform w/ladder
- Washdown - pressurized raw water w/hose

## Canvas Options

- Aft curtain
- Bow cover
- Drop curtain
- Vista top w/side curtains & boot

## OPTIONAL FEATURES

- Bow lifting ring
- Cockpit bolsters
- Cockpit shower w/10-gallon freshwater tank
- Forward bolsters
- Head - portable
- Hydraulic trim tabs
- Livewell - 16-gallon insulated raw water livewell
- Seating - deluxe helm & companion chairs

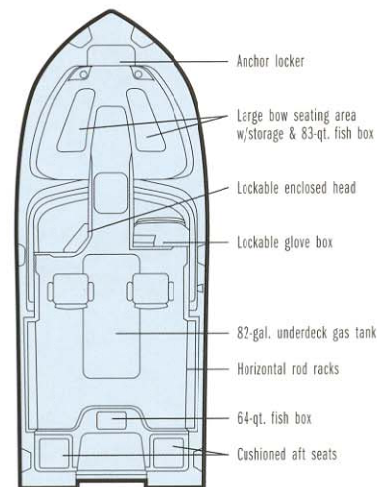

Lockable enclosed head area with storage nets



Cockpit forward with optional port sleeper seat



Helm station



Forward seating with insulated fish box

## CUSTOMER-IZATION

## A NEW GENERATION OF DUAL CONSOLES

There's a new generation of boaters and a new generation of boats built to make them happy: the new *Tournament* line from Grady-White. The *Tournament 205* joins the *185* and the *225* to bring fun-and-fishing families great choices in open bow models. Very versatile, and built for comfort—the *205* and *225* offer an enclosed head!









# ADVENTURE 208

"I TOOK MY 208 ALL THE WAY TO THE EXUMAS AND HAD A BLAST, even in heavy weather. You have a customer for life with me." —Kenneth Moore, Fort Lauderdale, FL, ADVENTURE owner

- Beam Amidships: 8'1"
- Bridge Clearance: 5'9"
- w/Hardtop: 8'
- Center Line Length: 20'4"
- Cockpit Depth: 25"
- Cockpit Square Footage: 41 sq. ft.
- Hull Draft: 14"
- Maximum HP: 230
- Outboard Shaft Length: 25"
- Standard Fuel Capacity: 82 gal.
- Transom Width: 7'10"
- Weight w/o engine: 2650 lb.



## STANDARD FEATURES

### Safety

- Automatic bilge pump (1250 GPH)
- Basic flotation
- Bow rail - 316 grade stainless steel
- Chrome-over-bronze through-hull fittings
- Cockpit toe rails
- Companion grab rail
- Fold down motorwell bulkhead
- Nonskid fiberglass liner
- Nonskid recessed walkaround
- Self-bailing cockpit w/4 cockpit drains

### Cabin

- Berth - forward vee berth
- Cabin light
- Forward hatch - low profile acrylic hatch w/screen
- Lockable door w/screen & companionway hatch
- Rod storage holders (4)
- Storage - portable head compartment
- Storage - under berth compartments (3)
- Windows - opening windows w/screens (2)

### Cockpit & Deck

- 100% hand laid hull & deck
- Accessory outlet - 12V (2)
- Cockpit lights

- Deck hardware - 316 grade stainless steel through-bolted
- Drink holders (6)
- Fish box - 103-qt. port insulated fish box w/ob drain
- Fish box - 106-qt. starboard insulated fish box w/ob drain
- Footrests (helm & companion)
- Fuel capacity - 82-gallon tank
- Heavy-duty gunwale molding
- International lighting
- Rod holders (4)
- Rod storage racks - horizontal (6)
- Seating - aft seats (2)
- Seating - helm & companion pedestal chairs
- Seating - foredeck cushions
- Seating - port & starboard fish box cushions
- Spring line cleats
- Steering - no-feedback mechanical
- Steering wheel - 316 grade stainless steel
- Stern eyes
- Storage - aft seat lift out boxes (2)
- Storage - forward anchor locker w/rope storage
- Storage - lockable electronics box
- Storage - lockable storage under helm chair
- Storage - tackle drawers under companion chair (2)

- Storage nets
- Windshield
- Windshield wiper (starboard)

### OPTIONAL FEATURES

- Bow lifting ring
- Bow pulpit
- Cockpit bolsters
- Cockpit shower w/10-gallon freshwater tank
- Hardtop w/radio box, spreader lights, & side mounted rod holders (4)
- Hardtop top mounted rod holders
- Head - portable
- Head - portable w/deck pump out
- Hydraulic trim tabs
- Livewell - 25-gallon insulated raw water livewell
- Steering - hydraulic (required w/4-stroke engine)
- Steering - tilt
- Swim platform w/ladder
- Washdown - pressurized raw water w/hose

### Canvas Options

- Drop curtain (hardtop or vista top)
- Hardtop front & side curtains
- Helm station cover
- Vista top w/side curtains & boot

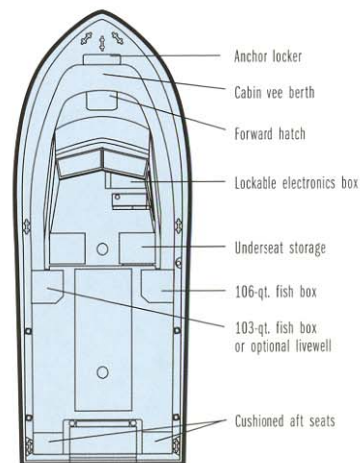

Cabin interior shown with auxiliary berth cushion



Helm station with lockable electronics box



Cockpit forward



Cushioned aft seating

## CUSTOMERIZATION



## THE ORIGINAL WALKAROUND CABIN AND EVER-EVOLVING DETAILS.

The direct forebearer of the 208, the *Hatteras 204c*, pioneered the walkaround cabin style in 1975. The concept was perfect for anglers, day trippers, and those who wanted to extend the boating season. There's 360-degree access, ease at anchoring and docking, and customer inspired details like handholds and grab rails wherever you need them.







"THE STABILITY THIS BOAT OFFERS MEANS GREAT SAFETY for our family, especially the kids."

—Scott & Ely Miller, Dousman, WI, *ESCAPE* owners

20' CENTER CONSOLE

# ESCAPE 209

- Beam Amidships: 8'1"
- Bridge Clearance: 5'9"  
w/T-top: 7'8"
- Center Line Length: 20'4"
- Cockpit Depth: 25"
- Cockpit Square Footage: 51 sq. ft.
- Hull Draft: 14"
- Maximum HP: 230
- Outboard Shaft Length: 25"
- Standard Fuel Capacity: 82 gal.
- Transom Width: 7'10"
- Weight w/o Engine: 2450 lb.

## STANDARD FEATURES

### Safety

- Automatic bilge pump (1250 GPH)
- Basic flotation
- Bow rail - low profile 316 grade stainless steel
- Chrome-over-bronze through-null fittings
- Cockpit toe rails
- Console grab rail
- Fold down motorwell bulkhead
- Nonskid fiberglass liner
- Self-bailing cockpit w/2 cockpit drains

### Cockpit & Deck

- 100% hard laid hull & deck
- Casting platform (raised)
- Cockpit lights
- Deck hardware - 316 grade stainless steel through-bolted
- Fish box - 83-qt. port insulated fish box w/ob drain
- Fish box - 120-qt. starboard insulated fish box w/ob drain
- Fuel capacity - 82-gallon tank
- Heavy-duty gunwale molding
- International lighting
- Rod holders (4)
- Rod storage racks - horizontal (6)
- Seating - aft seats (2)

- Seating - helm & companion pedestal chairs
- Spring line cleats
- Stern eyes
- Storage - aft rigging compartments (2)
- Storage - forward anchor locker w/rope storage

### Console

- Accessory outlet - 12V (2)
- Drink holders (2)
- Livewell - 28-gallon forward insulated raw water livewell w/ob drain
- Rod storage holders - vertical (6)
- Seating - forward console seat w/cushion
- Steering - no-feedback mechanical
- Steering wheel - 316 grade stainless steel
- Storage - lockable electronics box
- Storage - lockable storage compartments (2)
- Windshield - Plexiglas windshield w/handrail

### OPTIONAL FEATURES

- Bow lifting ring
- Cockpit bolsters
- Cockpit shower w/10gallon freshwater tank
- High bow rail
- Hydraulic trim tabs

- Livewell (lean bar option only) - 23-gallon insulated raw water livewell w/cushion
- Seating - bench seat w/reversible back
- Seating - forward platform cushions
- Seating - lean bar w/backrest, footrest, tackle trays, lockable storage & rod holders (4)
- Steering - hydraulic (required w/4 stroke engine)
- Steering - tilt
- Swim platform w/ladder
- T-top w/radio box, dome light, storage net, spreader light & rod holders (4)
- Washdown - pressurized raw water w/hose

### Canvas Options

- B mini top w/boot
- Console cover
- T-top front & side curtains

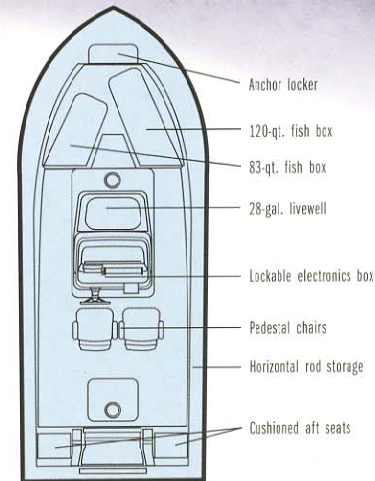
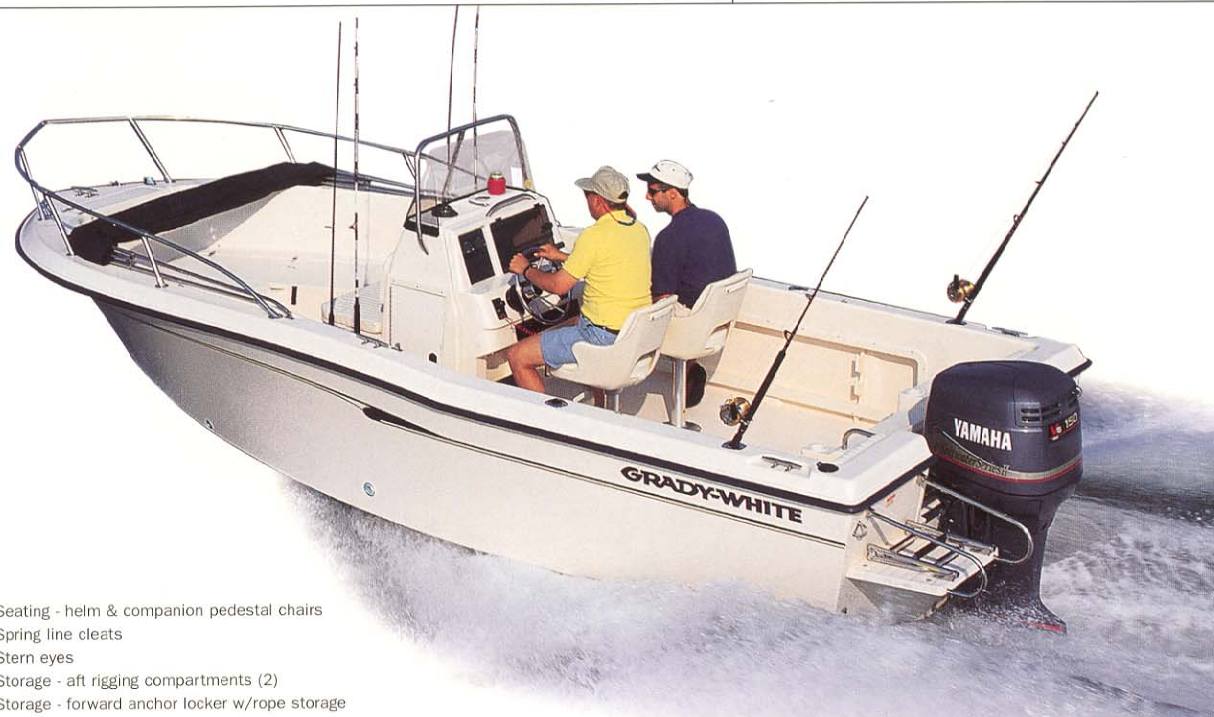

Cockpit forward with optional T-top and lean bar with tackle and bulk storage



Insulated bow fish boxes with overboard drains



Aft cockpit with fold down motorwell bulkhead

## CUSTOMER-IZATION



## CUSTOMERS WANT SUPER STRONG HARDWARE

Owners and dealers across the country love the 209 as a great inshore center console. They often dock their boats on lifts or in davits, giving a real workout to hardware. Customers wanted super fittings, so we worked with suppliers to design hardware just for Grady-White customers.





GRADY-WHITE

YAMAHA  
225  
POLY STRIKE



NOT ONLY IS THIS THE BEST FISHING BOAT OF ITS SIZE...great for casting, trolling...but it's versatile, too, good for tubing, skiing, and being with my family. With all we do, storage is at a premium and our 222 has room for it all! —George Milliken (and family), Annapolis, MD, FISHERMAN OWNERS

22' CENTER CONSOLE  
**FISHERMAN 222**

FISHERMAN 222

- Beam Amidships: 8'
- Bridge Clearance: 6'2"  
w/T-top: 8'
- Center Line Length: 22'2"
- Cockpit Depth: 25"
- Cockpit Square Footage: 55 sq. ft.
- Hull Draft: 16"
- Maximum HP: 250
- Outboard Shaft Length: 25"
- Standard Fuel Capacity: 96 gal.
- Transom Width: 7'11"
- Weight w/o Engine: 3160 lb.



Console with lockable electronics box, footrest and storage compartment

**STANDARD FEATURES**

- Safety**
- Automatic bilge pump (1700 GPH)
  - Basic flotation
  - Bow rail - low profile 316 grade stainless steel
  - Chrome-over-bronze through-hull fittings
  - Cockpit toe rails
  - Console grab rail
  - Fold down motorwell bulkhead
  - Nonskid fiberglass liner
  - Self-bailing cockpit w/4 cockpit drains

- Cockpit & Deck**
- 100% hand laid hull & deck
  - Casting platform (raised)
  - Cockpit lights
  - Deck hardware - 316 grade stainless steel through-bolted
  - Fish box - 55-qt. port & starboard insulated fish boxes w/ob drain
  - Fish box - 272-qt. center insulated fish box w/ob drain
  - Fuel capacity - 96-gallon tank
  - Heavy-duty gunwale molding
  - Hydraulic trim tabs
  - International lighting
  - Rod holders (4)
  - Rod storage racks - horizontal (6)

- Seating - helm & companion pedestal chairs
- Spring line cleats
- Stern eyes
- Storage - aft deck lift out boxes (2)
- Storage - forward anchor locker w/rope storage
- Washdown - pressurized raw water w/hose

- Console**
- Accessory outlet - 12V (2)
  - Drink holders (2)
  - Head - lockable console w/stand up head area & storage
  - Rod storage holders - vertical (6)
  - Seating - forward console seat w/cushion
  - Steering - hydraulic tilt
  - Steering wheel - 316 grade stainless steel
  - Storage - lockable electronics box
  - Storage - under footrest
  - Storage nets
  - Windshield - Plexiglas windshield w/handrail

**OPTIONAL FEATURES**

- Bow lifting ring
- Bow pulpit (includes high profile bow rail)
- Cockpit bolsters
- Cockpit shower w/10-gallon freshwater tank
- Head - portable
- Head - portable w/deck pump out
- Head - portable w/in-line macerator
- Livewell (lean bar option only) - 23-gallon insulated raw water livewell w/cushion
- Outrigger kit - 15-ft. Radial Top Gun T-top mounted
- Seating - deluxe lean bar w/footrest, backrest, tackle trays, lockable storage & rod holders (4)
- Seating - folding aft jump seats w/cushions (2)
- Seating - forward platform cushions
- Swim platform w/ladder
- T-top w/radio box, dome light, storage net, spreader light & rod holders (4)

**Canvas Options**

- Bimini top w/boot
- Console cover
- T-top front & side curtains

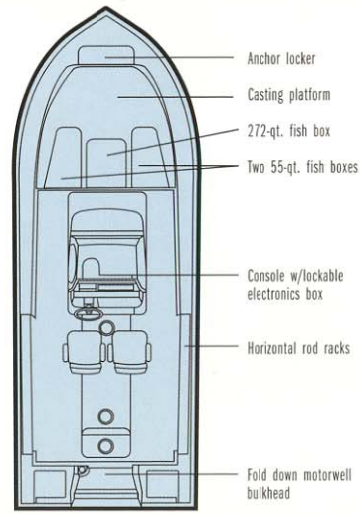

Casting platform's insulated bow fish boxes with overboard drains



Aft cockpit fold down motorwell bulkhead, aft lift out boxes, standard washdown and optional cockpit bolsters

**CUSTOMER-IZATION**

**RECESSED SPRING LINE CLEATS**

"Why not recess the spring line cleats?" an owner asked several years back. "I'd have less trouble getting fishing lines and ropes snagged accidentally." We took that suggestion to heart when we introduced our *Fisherman 222*. This is not only a nice convenience feature for fishermen, but can even be a smart safety feature.









IT ATTRACTS PEOPLE LIKE A MAGNET. Flexible and versatile...for fishing or on family outings. Our first 'big boat' and I was comfortable from day one. The boat feels safe and rides great with one person aboard or a boat full! My wife loves all the drink holders! —Thomas Iglar, Severn Park, MD, TOURNAMENT 225 OWNER

22' DUAL CONSOLE

# TOURNAMENT 225

- Beam Amidships: 8'
- Bridge Clearance: 5'6"
- Center Line Length: 22'2"
- Cockpit Depth: 25"
- Cockpit Square Footage: 49 sq. ft.
- Hull Draft: 16"
- Maximum HP: 250
- Outboard Shaft Length: 25"
- Standard Fuel Capacity: 96 gal.
- Transom Width: 7'11"
- Weight w/o Engine: 3450 lb.



## STANDARD FEATURES

### Safety

- Automatic bilge pump (1700 GPH)
- Basic flotation
- Bow rail - low profile 316 grade stainless steel
- Chrome-over-bronze through-hull fittings
- Cockpit toe rails
- Companion grab rail
- Nonskid fiberglass liner
- Self-bailing cockpit w/2 cockpit drains

### Cockpit & Deck

- 100% hand laid hull & deck
- Accessory outlet - 12V (2)
- Battery select switch
- Cockpit lights
- Cockpit shower w/10-gallon freshwater tank
- Deck hardware - 316 grade stainless steel through-bolted
- Drink holders (12)
- Fish box - 52-qt. starboard bow insulated fish box w/ob drain
- Fish box - 175-qt. aft insulated fish box w/ob drain
- Footrest (helm)
- Forward bolsters
- Fuel capacity - 96-gallon tank
- Head - lockable console head area w/storage nets

- Head - portable
- Heavy-duty gunwale molding
- Hydraulic trim tabs
- International lighting
- Rod holders (4)
- Rod storage racks - horizontal (6)
- Seating - bow cushions
- Seating - deluxe helm & companion chairs w/adjustable pedestal
- Seating - fold away aft bench seat
- Spring line cleats
- Steering - hydraulic tilt
- Steering wheel - 316 grade stainless steel
- Stern eyes
- Storage - 22-gallon insulated aft storage compartment
- Storage - forward anchor locker w/rope storage
- Storage - forward bow seat compartment
- Storage - lockable console storage compartment
- Storage - lockable console tackle drawers
- Storage - lockable electronics box
- Storage - port bow seat compartment
- Windshield - walk-through windshield
- Windshield wiper (starboard)

### OPTIONAL FEATURES

- Bow lifting ring
- Cockpit bolsters
- Head - portable w/deck pump out
- Head - portable w/in-line macerator
- Livewell - 22-gallon insulated raw water livewell w/light, full column distribution inlet & ob drain
- Seating - port sleeper seat
- Stereo/CD system
- Sun platform w/cushion
- Swim platform w/ladder
- Swim platform w/ladder (full width)
- Washdown - pressurized raw water w/hose

### Canvas Options

- Aft curtain
- Bow cover
- Drop curtain
- Vista top w/side curtains & boot

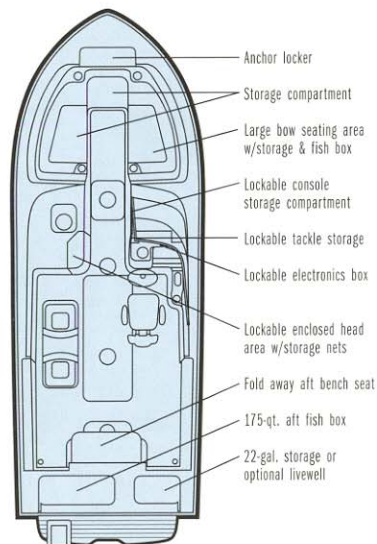

Cockpit forward with optional port sleeper seat



Lockable enclosed head area with storage nets



Bow area with optional sun platform with cushion



Transom with fold away bench seat, fish box and optional livewell

## CUSTOMER-IZATION



## A SLEEPER SEAT THAT'S COMFORTABLE FOR SITTING AND SNOOZING

We worked hard to develop a sleeper seat that was bigger, more handsome, and in keeping with the lines of the *Tournament 225*. But the real trick was ensuring our customers would be comfortable whether upright or prone. Seems that boat seats that are cozy for sitting aren't always that way for lying down. With our 225 optional sleeper seat, you'll always find comfort that's a dream.







"SHE'S EASY TO HANDLE, rides smooth as silk even in rough water, and she's stable, roomy and dry." —Dr. William Myers III, Charleston, SC, SEAFARER OWNER

22' WALKAROUND CABIN  
**SEAFARER 226/228**

- Beam Amidships: 8'
- Bridge Clearance: 6'2"  
w/Hardtop: 8'4"
- Center Line Length: 22'2"
- Cockpit Depth: 26"
- Cockpit Square Footage: 49 sq. ft.
- Hull Draft: 16"
- Maximum HP: 250
- Outboard Shaft Length: 25"
- Standard Fuel Capacity: 92 gal.
- Transom Width: 7'11"
- Weight w/o Engine
  - 226: 3385 lb. (standard transom)
  - 228: 3510 lb. (Grady Drive transom)

**STANDARD FEATURES**

**Safety**

- 2 automatic bilge pumps (total 2500 GPH)
- Basic flotation
- Bow rail - 316 grade stainless steel
- Chrome-over-bronze through-hull fittings
- Cockpit toe rails
- Companion grab rail
- Fold down motorwell bulkhead (226 only)
- Nonskid fiberglass liner
- Nonskid recessed walkaround
- Self-bailing cockpit w/4 cockpit drains

**Cabin**

- Berth - forward vee berth
- Cabin light
- Forward hatch - low profile acrylic hatch w/screen
- Lockable door w/screen & companionway hatch
- Rod storage holders (4)
- Sink
- Storage - cabinet
- Storage - portable head compartment
- Storage - under berth compartments (3)
- Windows - opening windows w/screens (2)

**Cockpit & Deck**

- 100% hand laid hull & deck
- Accessory outlet - 12V (2)
- Bait rigging area w/cutting board & drink holders (228 only)
- Cockpit lights
- Cockpit shower
- Deck hardware - 316 grade stainless steel through-bolted
- Drink holders (6)
- Fish box - 190-qt. starboard insulated fish box w/ob drain
- Fish box - divided port insulated fish box (80-qt. & 45-qt. sections w/ob drain)
- Fish box - 72-qt. aft fish box (228 only)
- Footrests (helm & companion)
- Fuel capacity - 92-gallon tank
- Heavy-duty gunwale molding
- Hydraulic trim tabs
- International lighting
- Rod holders (4)
- Rod storage holders - vertical (4) (228 only)
- Rod storage racks - horizontal (6)
- Seating - aft seats (2)
- Seating - foredeck cushions
- Seating - helm & companion pedestal chairs
- Seating - port aft facing seat
- Seating - starboard fish box cushion
- Spring line cleats
- Steering - hydraulic tilt
- Steering wheel - 316 grade stainless steel
- Stern eyes
- Storage - aft lift-out boxes
- Storage - forward anchor locker w/rope storage
- Storage - lockable helm station radio box
- Storage - tackle drawers under helm & companion chairs
- Storage nets
- Water tank - 10-gallon freshwater
- Windshield - ventilated windshield
- Windshield wiper (starboard)



**OPTIONAL FEATURES**

- Auxiliary fuel capacity - 56-gallon tank
- Bow lifting ring
- Bow pulpit
- Cockpit bolsters
- Hardtop w/radio box, storage net, spreader lights & side mounted rod holders (4)
- Hardtop top mounted rod holders
- Head - portable
- Head - portable w/deck pump out
- Head - portable w/in-line macerator
- Livewell - 20-gallon insulated raw water livewell
- Seating - deluxe helm & companion chairs
- Swim platform w/ladder
- Swim platform w/ladder (full width) (228 only)
- Washdown - pressurized raw water w/hose
- Windshield wiper (port)

**Canvas Options**

- Drop curtain (hardtop or vista top)
- Hardtop front & side curtains
- Helm station cover
- Vista top w/side curtains & boot

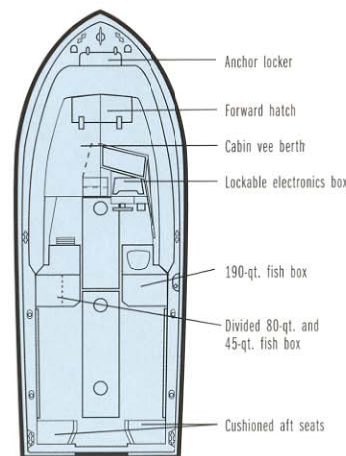

Cabin interior with port side sink; shown without auxiliary berth cushion



Helm station with lockable electronics box



Grady Drive cockpit aft with optional bolsters



Cockpit forward with divided port insulated fish box

SEAFARER 226/228

**CUSTOMER-IZATION**



**CUSTOMERS SAY "KEEP A CLEAR VIEW"**

Helm men need a clear view to safely operate and navigate their boats. Grady-White's answer: A well located instrument panel and backlit accessory switches that are easy to see even at dawn or dusk. And since instrument clutter is the enemy of good visibility, we offer lockable enclosed electronics boxes that help clear the dash.





**GRADY-WHITE**

**YAMAHA**



"I AM IN LOVE WITH THIS BOAT. It has exceeded all of my expectations. On the bay or all day out in the Gulf, it's not missing anything for fishing. I could tell just by looking at it, more thought went into this boat than others I saw!"—Mark Jones, Houston TX, , GULFSTREAM owner

23' WALKAROUND CABIN

# GULFSTREAM 232

- Beam Amidships: 9'3"
- Bridge Clearance: 6'5"  
w/Hardtop: 8'8"
- Center Line Length: 23'5"
- Cockpit Depth: 27"
- Cockpit Square Footage: 56 sq. ft.
- Hull Draft: 17"
- Maximum HP: 400
- Outboard Shaft Length  
Single: 25"  
Dual: 25"
- Standard Fuel Capacity: 148 gal.
- Transom Width: 8'10"
- Weight w/o Engine  
232S: 4025 lb.  
232D: 4092 lb.

## STANDARD FEATURES

### Safety

- 2 automatic bilge pumps (total 2950 GPH)
- Basic flotation
- Bow rail - 316 grade stainless steel
- Chrome-over-bronze through-hull fittings
- Cockpit toe rails
- Companion grab rail
- Nonskid fiberglass liner
- Nonskid recessed walkaround
- Self-bailing cockpit w/4 cockpit drains

### Cabin

- Berths - 2 berths (upper & lower)
- Cabin lights
- Forward hatch - low profile acrylic hatch w/screen
- Galley - portside galley w/sink
- Ice box - insulated ice box w/ob drain
- Lockable door w/screen & companionway hatch
- Rod storage holders (2)
- Storage - forward compartment
- Storage - port compartment
- Storage - portable head compartment

- Storage - under berth compartment
- Storage - under sink compartment
- Storage - under step compartment
- Storage nets
- Windows - opening windows w/screens (2)

### Cockpit & Deck

- 100% hand laid hull & deck
- Accessory outlet - 12V (2)
- Cockpit lights
- Cockpit shower
- Cutting board
- Deck hardware - 316 grade stainless steel through-bolted
- Drink holders (6)
- Factory engine pre-rigging
- Fish box - 265-qt. starboard insulated fish box w/ob drain
- Footrests - helm & companion (adjustable)
- Fuel capacity (single) - 148 gallons (92-gallon tank, 56-gallon tank)
- Fuel capacity (dual) - 146 gallons (90-gallon tank, 56-gallon tank)
- Heavy-duty gunwale molding
- Hydraulic trim tabs
- Ice box - two 38-qt. aft insulated ice boxes w/ob drain
- International lighting
- Livewell - 36-gallon port insulated raw water livewell w/ob drain
- Rod holders (4)
- Rod storage racks - horizontal (5)
- Seating - deluxe helm & companion chairs
- Seating - foredeck cushions
- Seating - molded in aft bench seat w/cushion
- Seating - port aft facing seat
- Seating - starboard fish box cushion
- Spring line cleats
- Steering - hydraulic tilt
- Steering wheel - 316 grade stainless steel



- Stern eyes
- Storage - forward anchor locker w/rope storage
- Storage - lockable electronics box
- Storage - tackle trays under helm chair (2)
- Storage - tackle drawers under companion seat (2)
- Washdown - pressurized raw water w/hose
- Water tank - 10-gallon freshwater
- Windshield - ventilated windshield
- Windshield wipers

- Swim platform w/ladder (small port side)
- Swim platform w/ladder (full width)
- Windshield washer - freshwater (starboard)

### Canvas Options

- Hardtop drop curtain
- Hardtop front & side curtains
- Helm station cover

## OPTIONAL FEATURES

- Bow lifting ring
- Bow pulpit
- Cockpit bolsters
- Cushions - auxiliary berth cushions
- Fuel capacity (dual only) - 182 gallons (92-gallon tank, 90-gallon tank) (not available w/200 HP 4-stroke engines)
- Hardtop w/radio box, storage net, spreader lights & side mounted rod holders (4)
- Hardtop top mounted rod holders
- Head - portable
- Head - portable w/deck pump out
- Head - portable w/in-line macerator
- Outrigger kit - 18-ft. Lee Jr. cabin side mounted (w/hardtop option only)
- Rod storage - folding cabin rack (6)
- Stereo/CD system

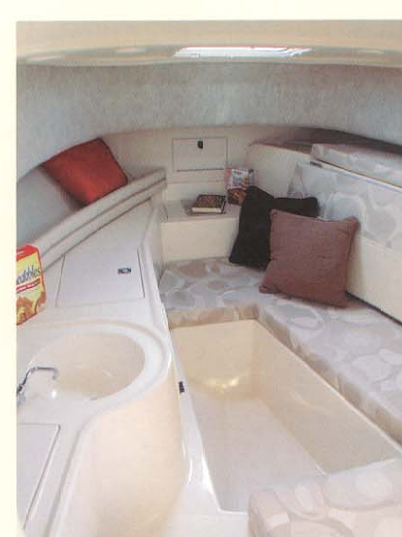
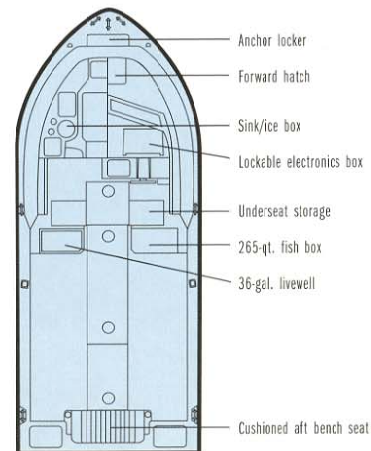

Cabin interior shown without optional auxiliary berth cushions



Helm station with lockable electronics box



Cockpit forward



Aft cockpit with optional cockpit bolsters

## CUSTOMERIZATION



## CUSTOMERS ASK FOR "HARDTOP ROD STORAGE WHERE I CAN REACH IT!"

Positive input from customers on our side mounted hardtop rod holders (first introduced on our *Express 330*) prompted us to make these easy-to-access holders a feature on all hardtops. Hardtop side mounted rod holders along with a host of carefully crafted fishing features make the 232 one of the best fishing boat values on the water.







"THE RIDE IS INCREDIBLY BETTER THAN OTHER BOATS. This boat is a better value; I looked at the others and compared. We fish Long Island Sound for striped bass and plan to go offshore for the shark and tuna." —Michael Gosselin, Hampton Bays, L.I., N.Y. *ADVANCE* OWNER

25' CENTER CONSOLE

# ADVANCE 257

ADVANCE 257

- Beam Amidships: 8'6"
- Bridge Clearance: 7'  
w/T-top: 8'5"
- Center Line Length: 24'9"
- Cockpit Depth: 27"
- Cockpit Square Footage: 64 sq. ft.
- Hull Draft: 16"
- Maximum HP: 350
- Outboard Shaft Length  
Single: 30"  
Dual: 25"
- Standard Fuel Capacity: 151 gal.
- Transom Width: 7'10"
- Weight w/o Engine: 3500 lb.



## STANDARD FEATURES

### Safety

- Automatic bilge pump (1700 GPH)
- Basic flotation
- Bow rail - low profile 316 grade stainless steel
- Chrome-over-bronze through-hull fittings
- Cockpit toe rails
- Console grab rail
- Nonskid fiberglass liner
- Self-bailing cockpit w/4 cockpit drains

### Cockpit & Deck

- 100% hand laid hull & deck
- Battery select switch
- Casting platform (raised)
- Cockpit bolsters
- Cockpit lights
- Cockpit shower
- Cutting board
- Deck hardware - 316 grade stainless steel through-bolted
- Drink holders (3)
- Factory engine pre-rigging
- Fish box - 185-qt. aft insulated fish box w/ob drain

- Fish box - 120-qt. divided port insulated fish box w/ob drain
- Fish box - 120-qt. starboard insulated fish box w/ob drain
- Fuel capacity - 151-gallon tank
- Heavy-duty gunwale molding
- Hydraulic trim tabs
- Integrated outboard mounting system w/swim platform & ladder
- International lighting
- Livewell - 32-gallon aft insulated raw water livewell w/light, full column distribution inlet & ob drain
- Rod holders (4)
- Rod storage racks - horizontal (6)
- Seating - deluxe lean bar w/footrest, backrest, knife & pliers holders (2), tackle trays, lockable storage & rod holders (4)
- Seating - fold away aft bench seat w/cushion
- Spring line cleats
- Stern eyes
- Storage - forward anchor locker w/rope storage
- Storage - forward tackle trays
- Transom door
- Washdown - pressurized raw water w/hose
- Water tank - 20-gallon freshwater

### Console

- Accessory outlet - 12V (2)
- Console ventilator
- Drink holders (2)
- Head - lockable console w/stand up head area, storage shelves & hanging locker
- Seating - molded forward console seat w/cushion
- Steering - hydraulic tilt
- Steering wheel - 316 grade stainless steel
- Storage - lockable electronics box
- Storage - under footrest
- Storage nets
- Windshield - Plexiglas windshield w/handrail

### OPTIONAL FEATURES

- Bow lifting ring
- Bow pulpit (includes high profile bow rail)
- Convenience package - forward bolsters & forward platform cushions
- Electronics flush mount kit
- Head - portable
- Head - portable w/deck pump out
- Head - portable w/in-line macerator
- Outrigger kit - 15-ft. Radial Top Gun T-top mounted
- Stereo/CD system

T-top w/rod holders, radio box, dome light, storage net & spreader light

### Canvas Options

T-top front & side curtains

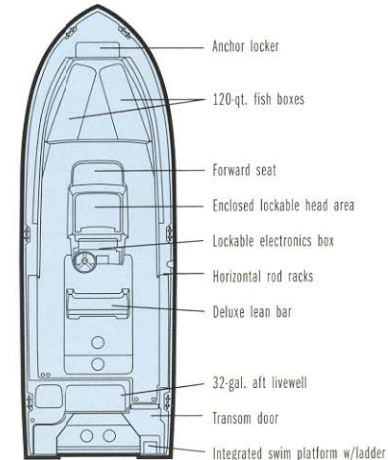

Lockable head enclosure with storage; shown with optional portable head



Console with lockable electronics box



Lean bar with rod holders, lockable tackle storage and bulk storage

## CUSTOMER-IZATION



## FISH BOX ACROSS THE BACK TRANSFORMS THE "BUSINESS END"

Customers tell us that the stern is where "the rubber meets the road" when it comes to fishing function. With input from past model *Advance* owners, we have included a fisherman's wish list at the 257 transom. A huge fish box. A positive locking transom door. And a full column water distribution inlet in the livewell. You'll be "king of the dock."





GRADY-WHITE

YAMAHA

YAMAHA

YAMAHA

YAMAHA



"It's PEACE OF MIND FOR THE FAMILY. I often run 10-12 miles off the Mississippi Coast with my two sons and wife, to the barrier islands. This nice, big, safe boat holds everything we need. If weather threatens, the cabin and zip up canvas are wonderful.—Greg Vickers, Hattiesburg, MS, 258 owner

25' WALKAROUND CABIN

# JOURNEY 258

JOURNEY 258

- Beam Amidships: 8'6"
- Bridge Clearance: 6'6"  
w/Hardtop: 8'8"
- Center Line Length: 24'9"
- Cockpit Depth: 27"
- Cockpit Square Footage: 55 sq. ft.
- Hull Draft: 16"
- Maximum HP: 350
- Outboard Shaft Length  
Single: 30"  
Dual: 25"
- Standard Fuel Capacity: 127 gal.
- Transom Width: 7'10"
- Weight w/o Engine: 4043 lb.



## STANDARD FEATURES

### Safety

- 2 automatic bilge pumps (total 2950 GPH)
- Basic flotation
- Bow rail - 316 grade stainless steel
- Chrome-over-bronze through-hull fittings
- Cockpit toe rails
- Companion grab rail
- Nonskid fiberglass liner
- Nonskid recessed walkaround
- Self-bailing cockpit w/4 cockpit drains

### Cabin

- Berth - forward vee berth
- Cabin light
- Carpet
- Forward hatch - low profile acrylic hatch w/screen
- Lockable door w/screen & companionway hatch
- Rod storage holders (4)
- Sink
- Storage - portable head compartment
- Storage - under berth compartments (5)
- Storage nets
- Windows - opening windows w/screens (2)

### Cockpit & Deck

- 100% hand laid hull & deck
- Accessory outlet - 12V (2)
- Battery select switch
- Cockpit lights
- Cockpit shower
- Cutting board
- Deck hardware - 316 grade stainless steel through-bolted
- Drink holders (7)
- Factory engine pre-rigging
- Fish box - 158-qt. starboard insulated fish box w/ob drain
- Footrest - helm & companion (adjustable)
- Fuel capacity - 127-gallon tank
- Heavy-duty gunwale molding
- Hydraulic trim tabs
- Ice box - 40-qt. aft insulated ice box w/ob drain
- Integrated outboard mounting system w/swim platform & ladder
- International lighting
- Livewell - 34-gallon port insulated raw water livewell
- Rod holders (6)
- Rod storage racks - horizontal (6)
- Seating - deluxe helm & companion chairs
- Seating - fold away aft bench seat w/cushion
- Seating - foredeck cushions
- Seating - port livewell cushion
- Seating - starboard fish box cushion
- Spring line cleats

- Steering - hydraulic tilt
- Steering wheel - 316 grade stainless steel
- Stern eyes
- Storage - forward anchor locker w/rope storage
- Storage - lockable electronics box
- Storage - lockable storage under helm seat
- Storage - tackle drawer under companion seat
- Storage - transom mounted knife & pliers holder
- Transom door
- Washdown - pressurized raw water w/hose
- Water tank - 10-gallon freshwater
- Windshield - ventilated windshield
- Windshield wiper (starboard)

### OPTIONAL FEATURES

- Auxiliary fuel capacity - 41-gallon tank
- Bow lifting ring
- Bow pulpit
- Cockpit bolsters
- Hardtop w/radio box, storage net, spreader lights & side mounted rod holders (4)
- Hardtop top mounted rod holders
- Head - marine head w/macerator, 10-gallon holding tank & pump out
- Head - portable
- Head - portable w/deck pump out
- Head - portable w/in-line macerator
- Rod storage - folding cabin rack (6)
- Stereo/CD system
- Windshield washer - freshwater (starboard)
- Windshield wiper (port)

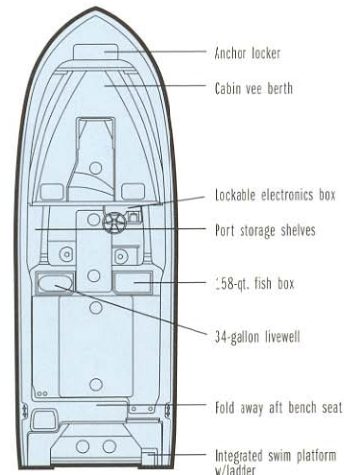

Helm station with lockable electronics box



Cabin interior with port side sink; shown without auxiliary berth cushion



158-qt. starboard insulated fish box with overboard drain



Aft cockpit with insulated box, cockpit shower, transom door and optional cockpit bolsters

## CUSTOMER-IZATION



## CUSTOMERS WANT TO FISH AND CRUISE. OUR FOLD AWAY AFT BENCH SEAT IS A VERSATILE SOLUTION.

"More seating for cruising," requests one customer. "Give me more room for fishing," asks another. The impossible task? Not for Grady-White's design and engineering team. We created the fold away aft bench seat to achieve both comfortable seating and, with the seat folded up, more cockpit room. Plus, transom rod holders keep rods out of the way and ready to go.





GRADY-WHITE

YAMAHA



"My wife enjoys the large berth for our three- and five-year old sons' naptimes. I enjoy the security and confidence in taking my family for fishing, swimming and extended day trips."

—Dave Mize, Richmond, VA, EXPRESS 265 owner

26' EXPRESS CABIN

# EXPRESS 265

EXPRESS 265

- Beam Amidships: 9'7"
- Bridge Clearance: 7'  
w/Hardtop: 10'1"
- Center Line Length: 25'9"
- Length Overall (w/pulpit): 28'6"
- Cockpit Depth: 26"
- Cockpit Square Footage: 58 sq. ft.
- Hull Draft: 18"
- Maximum HP: 500
- Outboard Shaft Length: 25"
- Standard Fuel Capacity: 250 gal.
- Transom Width: 8'8"
- Weight w/o Engine: 5390 lb.

- Storage nets
- Stove - butane
- Water tank -  
20-gallon freshwater

### Cockpit & Deck

- 100% hand laid hull & deck
- Accessory outlet - 12V (2)
- Anchor windlass wiring
- Bow pulpit
- Cockpit bolsters
- Cockpit lights
- Deck hardware - 316 grade stainless steel through-bolted
- Drink holders (6)
- Factory engine pre-rigging
- Fish box - 300-qt. insulated center fish box w/ob drain
- Fold down motorwell bulkhead
- Footrest - helm
- Fuel capacity - 250 gallons (130-gallon tank, 120-gallon tank)
- Heavy-duty gunwale molding
- Hydraulic trim tabs
- International lighting
- Livewell - 40-gallon insulated raw water livewell w/light, full column distribution inlet & ob drain
- Rigging station w/freshwater sink, insulated bait box w/ob drain & lockable drawers
- Rod holders (4)
- Rod storage racks - horizontal (6)
- Seating - foredeck cushions
- Seating - helm area surround seats
- Seating - port livewell cushion

- Seating - starboard tackle station cushion
- Seating - vertically & horizontally adjustable deluxe center helm chair
- Spring line cleats - flush mount
- Steering - hydraulic tilt
- Steering wheel - 316 grade stainless steel
- Stern eyes
- Storage - aft deck lift out boxes (2)
- Storage - dry storage below starboard surround seat
- Storage - forward anchor locker w/rope storage
- Storage - lockable electronics box
- Storage - tackle drawer below port bench seat
- Washdown - pressurized raw water w/hose
- Windshield - ventilated windshield
- Windshield washer - freshwater
- Windshield wiper

- Outrigger kit - 18-ft. Lee Jr. cabin side mounted (w/hardtop option only)
- Stereo/CD system
- Swim platform w/ladder

### Canvas Options

- Hardtop drop curtain
- Hardtop front & side curtains
- Helm station cover

### OPTIONAL FEATURES

- Anchor windlass
- Bow lifting ring
- Convenience package -  
Battery charger, dockside power w/galvanic isolator, microwave oven & water heater (6-gallon, 120V)
- Hardtop w/radio box, storage net, spreader lights & side mounted rod holders (4)
- Hardtop top mounted rod holders
- Head - marine head w/electric flush (10-gallon)

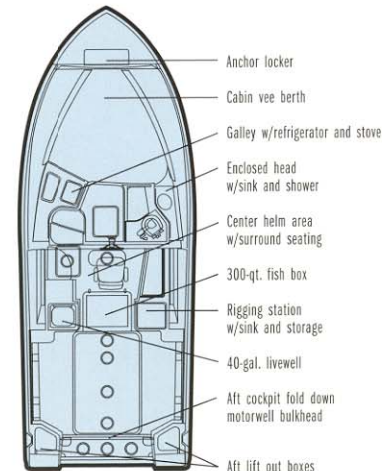

Helm station with lockable electronics box



Helm area with removable seat backs and vertically and horizontally adjustable helm chair



Cabin interior



Aft cockpit with fold down motorwell bulkhead, aft deck lift out boxes and horizontal rod storage

### STANDARD FEATURES

#### Safety

- 2 automatic bilge pumps (total 2950 GPH)
- Basic flotation
- Bow rail - 316 grade stainless steel
- Chrome-over-bronze through-hull fittings
- Cockpit toe rails
- Companion grab rail
- Nonskid fiberglass liner
- Self-bailing cockpit w/4 cockpit drains

#### Cabin

- Berth - forward vee berth
- Cabin lights
- Carpet
- Forward hatch - low profile acrylic hatch w/screen
- Galley - port side galley w/sink
- Head - enclosed head area w/sink, shower & lamp
- Head - marine head w/macerator, 10-gallon holding tank & pump out
- Lockable door w/screen & companionway hatch
- Mirror
- Refrigerator
- Rod storage holders (6)
- Storage - galley area
- Storage - under berth compartments (3)

### CUSTOMER-IZATION



### A TRANSM STYLE FOR FISH-FIGHTING AROUND THE ENGINES

Born and bred to go long range for the world's toughest game fish, the 265 is chock full of customer inspired details you just won't find on other brands. Anglers from New Jersey to Florida to Texas to the Pacific Coast love the transom, especially with tuna near the boat. The cockpit is huge. Rear-facing seats make bait watching a joy. And big insulated boxes keep the catch fresh.





GRADY-WHITE

225

YAMAHA

225

YAMAHA



"EVER HAD A TOY AS A KID that all the other kids wanted? That sums it up for me."

—Jeff Brooks, Virginia Beach, VA, ISLANDER owner

27' WALKAROUND CABIN

# ISLANDER 270

- Beam Amidships: 8'6"
- Bridge Clearance: 7' w/Hardtop: 9'3"
- Center Line Length: 26'11"
- Length Overall (w/pulpit): 29'4"
- Cockpit Depth: 28"
- Cockpit Square Footage: 57 sq. ft.
- Hull Draft: 17"
- Maximum HP: 500
- Outboard Shaft Length
  - Single: 30"
  - Dual: 25"
- Standard Fuel Capacity: 150 gal.
- Transom Width: 7'10"
- Weight w/o Engine: 4660 lb.

- Refrigerator
- Rod storage holders (2)
- Storage - galley area
- Storage - under berth compartments (3)
- Storage - under step compartment
- Storage nets
- Stove - butane
- Table
- Water tank - 32-gallon freshwater
- Windows - sliding side windows w/screens (2)

### Cockpit & Deck

- 100% hand laid hull & deck
- Accessory outlet - 12V (2)
- Anchor windlass wiring
- Battery select switch
- Bow pulpit (recessed)
- Cockpit lights
- Cockpit shower (recessed)
- Deck hardware - 316 grade stainless steel through-bolted
- Drink holders (6)
- Factory engine pre-rigging
- Fish box - 250-qt. starboard insulated fish box w/ob drain

- Footrest - helm (adjustable)
- Fuel capacity - 150-gallon tank
- Heavy-duty gunwale molding
- Hydraulic trim tabs
- Ice box - 40-qt. aft insulated ice box w/ob drain
- Integrated outboard mounting system w/swim platform & ladder
- International lighting
- Livewell - 34-gallon raw water livewell w/light, full column distribution inlet & ob drain
- Rod holders (6)
- Rod storage racks - horizontal (6)
- Seating - fold away aft bench seat w/cushion
- Seating - foredeck cushions
- Seating - horizontally adjustable deluxe companion chair
- Seating - port livewell cushion
- Seating - starboard fish box cushions
- Seating - vertically & horizontally adjustable deluxe helm chair (starboard)
- Spring line cleats
- Steering - hydraulic tilt
- Steering wheel - 316 grade stainless steel
- Stern eyes
- Storage - forward anchor locker w/rope storage

- Storage - lockable electronics box
- Storage - lockable storage behind helm seat
- Storage - tackle drawers under companion seat (4)
- Storage - transom mounted knife & pliers holder
- Transom door
- Washdown - pressurized raw water w/hose
- Windshield - ventilated windshield
- Windshield wipers

### Canvas Options

- Drop curtain (hardtop or vista top)
- Hardtop front & side curtains
- Helm station cover
- Vista top w/side curtains & boot

### OPTIONAL FEATURES

- Anchor windlass
- Auxiliary fuel capacity - 50 gallons (duals only)
- Bow lifting ring
- Cockpit bolsters
- Convenience package - Battery charger, dockside power w/galvanic isolator, microwave oven & water heater (6-gallon, 120V)
- Hardtop w/radio box, storage net, spreader lights & side mounted rod holders (4)
- Hardtop top mounted rod holders
- Head - marine head w/electric flush (10-gallon)
- Outrigger kit - 18-ft. Lee Jr. cabin side mounted (w/hardtop option only)
- Rod storage - folding cabin rack (4)
- Seating - companion bench seat
- Stereo/CD system
- Windshield washer - freshwater (starboard)

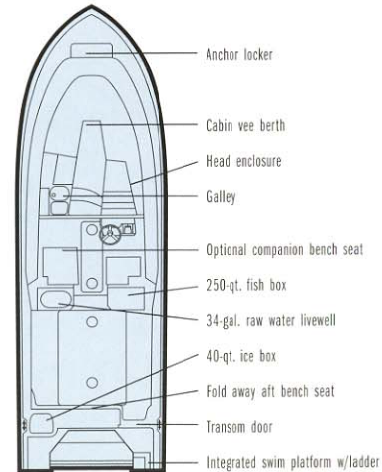

Helm station with lockable electronics box



Optional companion bench seat

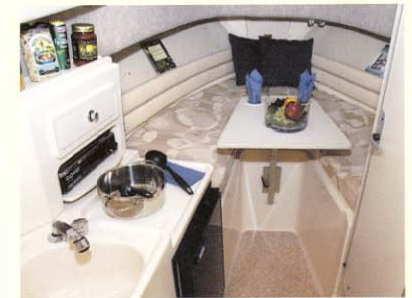

Cabin interior



Helm station with adjustable deluxe helm and companion chairs

### STANDARD FEATURES

#### Safety

- 2 automatic bilge pumps (total 2950 GPH)
- Basic flotation
- Bow rail - 316 grade stainless steel
- Chrome-over-bronze through-hull fittings
- Cockpit toe rails
- Companion grab rail
- Nonskid fiberglass liner
- Nonskid recessed walkaround
- Self-bailing cockpit w/4 cockpit drains

#### Cabin

- Berth - forward vee berth
- Cabin lights
- Cabin window curtains
- Carpet
- Forward hatch w/screen
- Galley - port side galley w/sink
- Head - enclosed head area w/sink, shower & lamp
- Head - marine head w/macerator, 10-gallon holding tank & pump out
- Ice box - 15-qt. insulated ice box w/ob drain
- Lockable door w/screen & companionway hatch
- Mirror

### CUSTOMER-IZATION

### A TRAILERABLE BOAT HELPS CUSTOMERS WHEN SLIP AVAILABILITY IS AT A PREMIUM.

The *Islander 270* incorporates many of the seating and storage suggestions we heard from customers during the remake of our *Sailfish 282*. This trailerable, 8' 6" beam big boat is a great choice especially if you live where slip or dry dock space is at a premium. The single engine option makes this a special value, too.







GRADY-WHITE

YAMAHA  
POLY BRONZE



"I AM A HAPPY MAN WITH MY 273, and this is my third new Grady-White."

—Martin Lodovico, Palm Harbor, FL, CHASE owner

27' CENTER CONSOLE

# CHASE 273

CHASE 273

- Beam Amidships: 8'6"
- Bridge Clearance: 6'9"  
w/T-top: 8'3"
- Center Line Length: 26'11"
- Cockpit Depth: 27"
- Cockpit Square Footage: 65 sq. ft.
- Hull Draft: 17"
- Maximum HP: 500
- Outboard Shaft Length  
Single: 30"  
Dual: 25"
- Standard Fuel Capacity: 205 gal.
- Transom Width: 7'10"
- Weight w/o Engine: 3975 lb.

## STANDARD FEATURES

### Safety

- 2 automatic bilge pumps (2950 GPH)
- Basic flotation
- Bow rail - low profile 316 grade stainless steel
- Chrome-over-bronze through-hull fittings
- Cockpit toe rails
- Nonskid fiberglass liner
- Self-bailing cockpit w/4 cockpit drains

### Cockpit & Deck

- 100% hand laid hull & deck
- Anchor windlass wiring
- Battery select switch
- Cockpit bolsters
- Cockpit lights
- Cockpit shower
- Cutting board
- Deck hardware - 316 grade stainless steel through-bolted
- Drink holder
- Factory engine pre-rigging
- Fish box - 104-qt. divided port insulated fish box w/ob drain
- Fish box - 104-qt. starboard insulated fish box w/ob drain



- Fish box - 185-qt. aft deck insulated fish box w/ob drain
- Fuel capacity - 205-gallon tank
- Heavy-duty gunwale molding
- Hydraulic trim tabs
- Integrated outboard mounting system w/swim platform & ladder
- International lighting
- Livewell - 32-gallon aft deck insulated raw water livewell w/light, full column distribution inlet & ob drain
- Rod holders (4)
- Rod storage - lockable horizontal storage for 6 rods
- Seating - deluxe lean bar w/footrest, backrest, tackle trays, lockable storage, 4 rod holders & removable 94-qt. cooler
- Seating - fold away aft bench seat w/cushion
- Spring line cleats
- Stern eyes
- Storage - forward anchor locker w/rope storage
- Transom door
- Washdown - pressurized raw water w/hose
- Water tank - 20-gallon freshwater

### Console

- Accessory outlet - 12V (2)
- Console ventilator
- Drink holders (2)
- Head - lockable console w/stand up head area, sink, bulk storage & drawers

- Seating - molded forward console seat w/cushion
- Steering - hydraulic tilt
- Steering wheel - 316 grade stainless steel
- Storage - electro-mechanically operated electronics enclosure
- Windshield - Plexiglas windshield w/handrail

## OPTIONAL FEATURES

- Anchor windlass
- Bow lifting ring
- Bow pulpit (includes high profile bow rail)
- Casting platform insert
- Casting platform insert cushions & fish box cushions
- Convenience package - Forward bolsters & fish box cushions
- Head - portable
- Head - portable w/deck pump out
- Head - portable w/in-line macerator
- Head - marine head w/macerator, 10-gallon holding tank & pump out
- Head - marine head w/electric flush (10-gallon)
- Outrigger kit - 15-ft. Radial Top Gun T-top mounted
- Stereo/CD system
- T-top w/radio box, dome light, storage net, spreader light & rod holders (4)

## Canvas Options

T-top front & side curtains

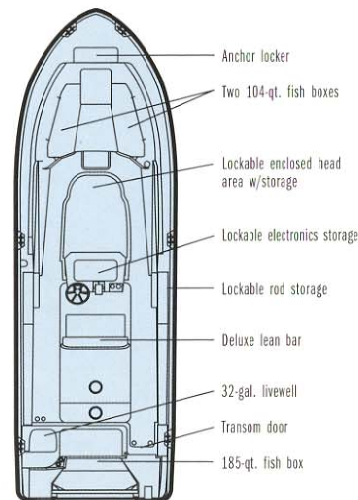

Bow fish boxes convert to bow seats; optional forward bolsters  
(See boat to the left for optional casting platform.)



Console with electro-mechanically operated electronics enclosure



Lockable rod storage



Fold away aft bench seat, livewell, 185-qt. fish box, and transom door.

## CUSTOMER-IZATION

## MOVE ALL THE WAY FORWARD AT ONE LEVEL

Ever try to maneuver to the bow with a big fish on? Customers told us they wanted a low center of gravity when moving forward to fight a fish. So we engineered access all the way forward at one level. And when you want a full casting platform, a clever insert fills the bill. There's room underneath for a 5-gallon net bucket and 48-quart cooler, too.









"ON OUR FIRST TRIP ABOARD OUR SAILFISH 282, we caught a kingfish and a tuna, and then released a sailfish.

What a wonderful beginning! Ours is a spectacular boat."

—Daniel Dunlavey, Pompano Beach, FL, SAILFISH owner

28' WALKAROUND CABIN

# SAILFISH 282

- Beam Amidships: 9'6"
- Bridge Clearance: 7'7"  
w/Hardtop: 9'9"
- Center Line Length: 28'
- Length Overall (w/pulpit): 30'2"
- Cockpit Depth: 28"
- Cockpit Square Footage: 59 sq. ft.
- Hull Draft: 18"
- Maximum HP: 600
- Outboard Shaft Length: 25"
- Standard Fuel Capacity: 220 gal.
- Transom Width: 9'
- Weight w/o Engines: 5800 lb.

- Mirror
- Refrigerator
- Rod storage holders (4)
- Storage - galley shelves
- Storage - under berth compartments (3)
- Storage nets
- Stove - butane
- Table
- Water heater - 6-gallon, 120V
- Water tank - 32-gallon freshwater
- Windows - opening windows w/screens (2)

### Cockpit & Deck

- 100% hand laid hull & deck
- Accessory outlet - 12V (2)
- Anchor windlass wiring
- Battery charger system
- Bow pulpit
- Cockpit bolsters
- Cockpit lights
- Cutting board
- Deck hardware - 316 grade stainless steel through-bolted
- Dockside power w/galvanic isolator
- Drink holders (7)
- Factory engine pre-rigging
- Fish box - 325-qt. starboard insulated fish box w/ob drain
- Footrests - helm & companion (adjustable)
- Fuel capacity - 220 gallons (150-gallon tank, 70-gallon tank)
- Hardtop w/radio box, storage net, spreader lights & side mounted rod holders (4)
- Hardtop drop curtain
- Hardtop front & side curtains
- Heavyduty gunwale molding
- Hydraulic trim tabs
- Ice box - 46-qt. aft deck insulated ice box w/ob drain
- Integrated outboard mounting system w/swim platform & ladder
- International lighting

- Livewell - 40-gallon insulated raw water livewell w/light, full column distribution inlet & ob drain
- Rigging station - aft deck station w/freshwater sink & pull out faucet
- Rod holders (4)
- Rod storage racks - horizontal (6)
- Seating - foredeck cushions
- Seating - molded in aft bench seat w/cushion
- Seating - port & starboard fish box cushions
- Seating - vertically & horizontally adjustable deluxe helm & companion chairs
- Spring line cleats
- Steering - hydraulic tilt
- Steering wheel - 316 grade stainless steel
- Stern eyes
- Storage - aft bench seat lift out tackle tray
- Storage - forward anchor locker w/rope storage
- Storage - lockable electronics box
- Storage - lockable storage under companion seat
- Storage - tackle drawers under helm seat (2)
- Transducer mounting flats
- Transom door
- Washdown - pressurized raw water w/hose
- Windshield - ventilated windshield
- Windshield washer - freshwater (starboard)
- Windshield wipers

- Hardtop top mounted rod holders
- Head - marine head w/electric flush (10-gallon)
- Outrigger kit - 18-ft. Lee Jr. cabin side mounted (w/hardtop option only)
- Rod storage - folding cabin rack (6)
- Seating - companion bench seat
- Stereo/CD system

### Canvas Options

- Helm station cover

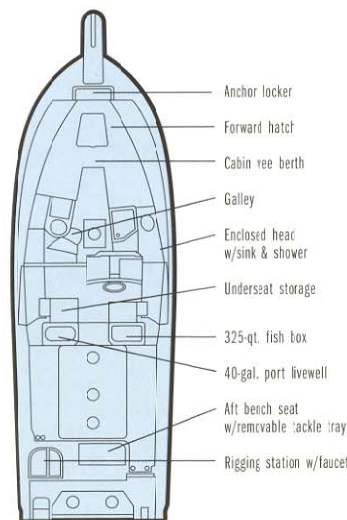

### OPTIONAL FEATURES

- Air conditioning
- Anchor windlass
- Bow lifting ring



Helm station with lockable electronics box



Cockpit forward with vertically and horizontally adjustable deluxe helm and companion chairs



Cabin interior



325-qt. starboard insulated fish box

### STANDARD FEATURES

#### Safety

- 2 automatic bilge pumps (total 2950 GPH)
- Basic flotation
- Bow rail - 316 grade stainless steel
- Chrome-over-bronze through-hull fittings
- Cockpit toe rails
- Companion grab rail
- Nonskid fiberglass liner
- Nonskid recessed walkaround
- Self-bailing cockpit w/4 cockpit drains

#### Cabin

- Berth - forward vee berth
- Berth - aft berth
- Cabin lights
- Cabin window curtains
- Carpet
- Forward hatch - low profile acrylic hatch w/screen
- Galley - port side galley w/sink & insulated ice box w/ob drain
- Head - enclosed head area w/sink, shower & lamp
- Head - marine head w/macerator, 10-gallon holding tank & pump out
- Lockable door w/screen & companionway hatch
- Microwave oven

### CUSTOMER-IZATION

### A LIVE WELL THAT ACTUALLY KEEPS BAIT ALIVE

Any raw water recirculating livewell can keep a few baits alive for a while in cold water. Anglers want to keep lots of bait alive for a long time even in very warm water. No puny livewell with a puny pump can do the job. We responded with our lighted, insulated raw water livewell with full column water distribution inlet and 1100 GPH pump.







GRADY-WHITE

YAMAHA



"DESIGNED WITH THE FISHERMAN IN MIND, and for his wife right there beside him. The finest boat we've ever owned, and we've had ten." —Dennis & Helen Owens, Delray Beach, FL, *RELEASE* owners

28' CENTER CONSOLE

# RELEASE 283

- Beam Amidships: 9'6"
- Bridge Clearance: 7'7"  
w/T-top: 8'5"
- Center Line Length: 28'
- Cockpit Depth: 27"
- Cockpit Square Footage: 69 sq. ft.
- Hull Draft: 18"
- Maximum HP: 600
- Outboard Shaft Length: 25"
- Standard Fuel Capacity: 205 gal.
- Transom Width: 9'
- Weight w/o Engines: 5520 lb.

## STANDARD FEATURES

### Safety

- 2 automatic bilge pumps (total 2950 GPH)
- Basic flotation
- Bow rail - low profile 316 grade stainless steel
- Chrome-over-bronze through-hull fittings
- Cockpit toe rails
- Console grab rail
- Nonskid fiberglass liner
- Self-bailing cockpit w/4 cockpit drains

### Cockpit & Deck

- 100% hand laid hull & deck
- Anchor windlass wiring
- Battery select switch
- Cockpit bolsters
- Cockpit lights
- Cutting board
- Deck hardware - 316 grade stainless steel through-bolted
- Drink holders (4)
- Factory engine pre-rigging
- Fish box - 135-qt. port & starboard insulated fish boxes w/ob drain
- Fish box - 265-qt. aft deck insulated fish box w/removable partition & ob drain
- Fuel capacity - 205-gallon tank
- Heavy-duty gunwale molding
- Hydraulic trim tabs
- Integrated outboard mounting system w/swim platform & ladder

- International lighting
- Rod holders (4)
- Rod storage - lockable horizontal storage for 6 rods (up to 9')
- Seating - fold away aft bench seat w/cushion
- Spring line cleats
- Stern eyes
- Storage - aft deck lift out box (also fits in forward port fish box)
- Storage - forward anchor locker w/rope storage
- Transducer mounting flats
- Transom door
- Washdown - pressurized raw water w/hose
- Water tank - 20-gallon freshwater

### Console

- Accessory outlet - 12V (2)
- Console ventilator
- Drink holders (2)
- Head - lockable console w/stand up head area, shower, sink, bulk storage & crawlers
- Head - marine head w/macerator, 10-gallon holding tank & pump out
- Seating - molded forward console seat w/cushion
- Steering - hydraulic tilt
- Steering wheel - 316 grade stainless steel
- Storage - electro-mechanically operated electronics enclosure
- Storage - under footrest
- Windshield - Plexiglas windshield w/handrail

### Deluxe Lean Bar

- Backrest
- Bait rigging locker
- Footrest
- Knife, pliers & rig holders (2)
- Livewell - 45-gallon insulated raw water livewell w/light, full column distribution inlet & ob drain

- Rod holders (4)
- Sink w/pull out freshwater faucet
- Storage - lockable tackle drawer
- Storage - lockable tackle locker w/tackle trays
- Storage - port net storage area

### OPTIONAL FEATURES

- Anchor windlass
- Bow lifting ring
- Bow pulpit (includes high profile bow rail)
- Casting platform insert
- Casting platform insert cushions
- Convenience package #1 - Battery charger & dockside power w/galvanic isolator
- Convenience package #2 - Forward bolsters & forward fish box cushions
- Head - marine head w/electric flush (10-gallon)
- Outrigger kit - 15 ft. Radial Top Gun T-top mounted
- Stereo/CD system
- T-top w/radio box, dome light, storage net, spreader light & rod holders (4)

### Canvas Options

- T-top front & side curtains

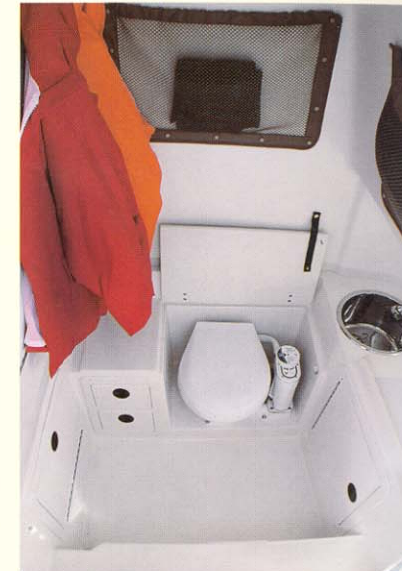
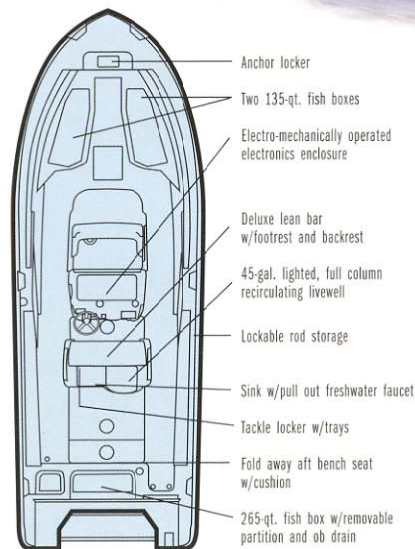
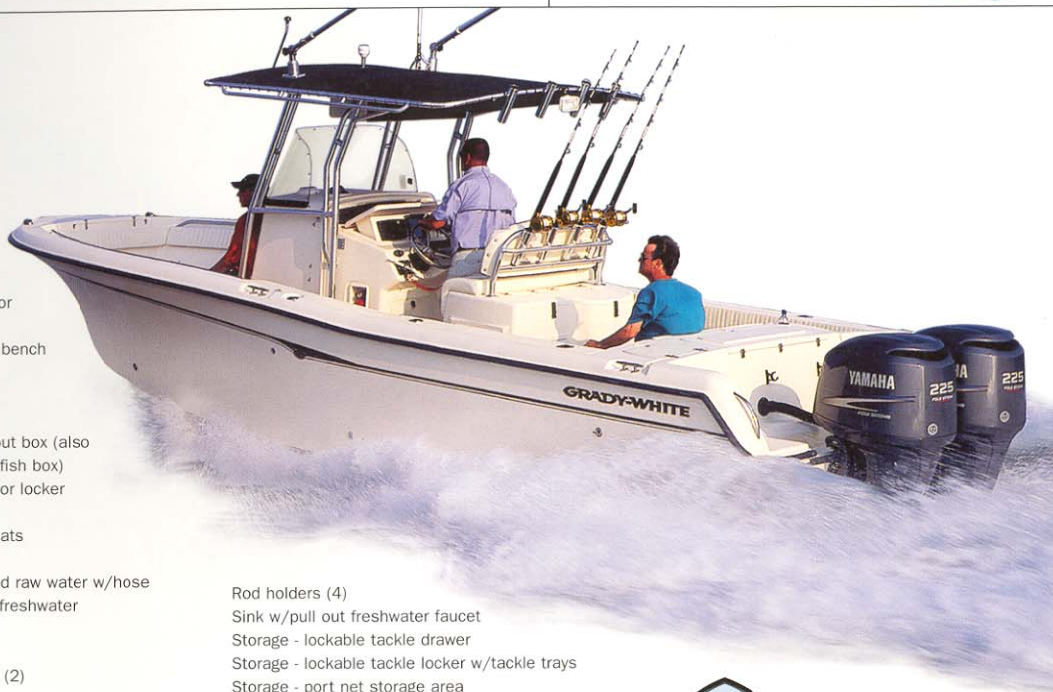

Lockable head enclosure with fold down cover, sink and storage



Helm console with electro-mechanically operated lockable electronics enclosure



Deluxe lean bar rigging station with livewell,

## CUSTOMER-IZATION



## EXPANDABLE BOX ACCOMMODATES 50-POUND-PLUS FISH AND CONSERVES ICE.

Some days you catch 'em and some days you really catch 'em! A clever transom fish box design on the *RELEASE* 283 employs a removable poly divider to accommodate fish as big as 50–80 pounds, and saves ice and room when the catch is a little smaller. A handy removable container in the divided space is great for baits or as a catch-all on cruising days.







## MARLIN 300



Cabin interior



Cabin interior with optional flatscreen TV and DVD player



Hartop lockable electronics boxes and net storage



Fold away bench seat, transom door, fish box and lift out box



Rod storage racks (6)  
 Rod storage - aft berth  
 Stereo/CD system  
 Storage - galley cabinet & counter  
 Storage - under berth compartments  
 Storage nets  
 Stove - electric glass top  
 Teak & holly floor  
 Teak table  
 Water heater - 6-gallon, 120V  
 Water tank - 39-gallon freshwater  
 Window - aft berth window w/screen  
 Windows - opening windows w/screens (2)

**Cockpit & Deck**  
 100% hand laid hull & deck  
 Accessory outlet - 12V (2)  
 Anchor windlass wiring  
 Battery select switch  
 Batteries (4)  
 Battery charger system  
 Bow pulpit w/roller  
 Cockpit bolsters  
 Cockpit lights  
 Cockpit freshwater shower (recessed)  
 Compass  
 Deck hardware - 316 grade stainless steel through-bolted  
 Dockside power w/galvanic isolator  
 Drink holders (10)  
 Dynaplate  
 Factory engine pre-rigging  
 Fighting chair reinforcement  
 Fish box - 290-qt. aft insulated fish box w/ob drain  
 Footrests - helm & companion (adjustable)  
 Freshwater level indicator  
 Fuel capacity - 306 gallons (150-gallon tank, 156-gallon tank)  
 Hardtop w/radio box, storage net, spreader lights & side mounted rod holders (4)  
 Hardtop drop curtain  
 Hardtop front & side curtains  
 Heavy-duty gunwale molding  
 Hydraulic trim tabs  
 Integrated outboard mounting system w/swim platform & ladder  
 International lighting  
 Livewell - 32-gallon insulated raw water livewell w/light, full column distribution inlet & ob drain w/1100 GPH pump

Rigging station behind helm chair w/freshwater sink, insulated bait box w/ob drain & lockable drawers  
 Rod holders (4)  
 Rod storage racks - horizontal (6)  
 Seating - fold away aft bench seat w/cushion  
 Seating - foredeck cushions  
 Seating - port fish box cushion  
 Seating - starboard tackle station cushion  
 Seating - vertically & horizontally adjustable deluxe helm & companion chairs  
 Spring line cleats  
 Steering - hydraulic tilt  
 Steering wheel - 316 grade stainless steel  
 Stern eyes  
 Storage - aft deck lift out box  
 Storage - forward anchor locker w/rope storage  
 Storage - lockable electronics box  
 Storage - lockable storage under helm & companion seats  
 Storage - under step compartment  
 Transducer mounting flats  
 Transom door  
 Washdown - pressurized raw water w/hose  
 Windshield - ventilated windshield  
 Windshield washer - freshwater (starboard)  
 Windshield wipers

Flush mount electronics kit  
 Generator - specify diesel or gas  
 Hardtop top mounted rod holders  
 Outrigger kit - 19-ft. Lee Jr. cabin side mounted  
 Outrigger kit - 24-ft. Lee Pro Series (lay out)  
 Rod storage - folding cabin rack (4)  
 Seating - companion bench seat

**Canvas Options**

Helm station cover

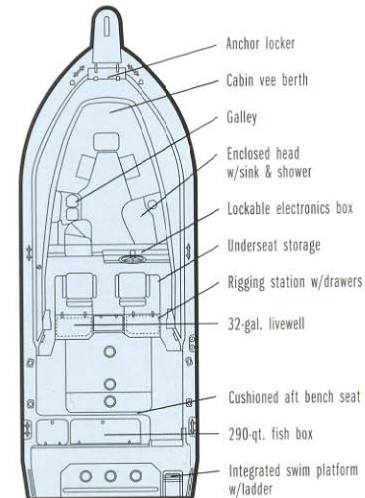
**OPTIONAL FEATURES**

Air conditioning  
 Anchor windlass  
 Bow thruster  
 Flatscreen TV w/DVD player

"WE CAN'T TELL YOU HOW PLEASED our fishing charter clients and we have been with the performance and quality of our Marlin 300." —Captains Jill and Troy Sapp, Odessa, FL, MARLIN owners

**Beam Amidships: 10'7"**  
**Bridge Clearance: 8'3"**  
 w/Hardtop: 9'9"  
**Center Line Length: 30'6"**  
**Length Overall (w/pulpit): 32'7"**  
**Cockpit Depth: 29"**  
**Cockpit Square Footage: 74 sq. ft.**  
**Hull Draft: 19"**  
**Maximum HP: 600**  
**Outboard Shaft Length: 25"**  
**Standard Fuel Capacity: 306 gal.**  
**Transom Width: 9'6"**  
**Weight w/o Engines: 7500 lb.**

**STANDARD FEATURES****Safety**

2 automatic bilge pumps (total 2950 GPH)  
 Basic flotation  
 Bow rail - 316 grade stainless steel  
 Chrome-over-bronze through-hull fittings  
 Cockpit toe rails  
 Companion grab rail  
 Nonskid fiberglass liner  
 Nonskid recessed walkaround  
 Self-bailing cockpit w/4 cockpit drains

**Cabin**

Berth - aft double berth  
 Berth - forward vee berth  
 Cabin lights  
 Cabin window curtains  
 Carpet  
 Cutting board - Corian®  
 Forward hatch - low profile acrylic hatch w/screen & shade  
 Galley - port side galley w/sink  
 Head - enclosed head area w/sink, shower & lamp  
 Head - VacuFlush® marine head (10-gallon)  
 Lockable door w/screen & companionway hatch  
 Microwave oven  
 Mirror  
 Refrigerator

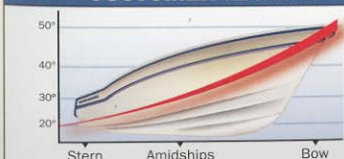
**CUSTOMER-IZATION****A SUPERIOR RIDE, STABILITY AND HANDLING—THE SEA V<sup>2</sup> HULL**

Prior to 1988's introduction of the SeaV<sup>2</sup> hull on the Marlin 300, traveling through rough water at good speed in a small fiberglass boat could be a slam-fest. Customers told us in no uncertain terms they wanted a superior ride. C. Raymond Hunt Associates and Grady-White collaborated to produce the continuously variable SeaV<sup>2</sup> hull. The industry's best ride now belongs to Grady-White in every size category.





GRADY-WHITE

YAMAHA



"FOR US, IT'S THE PERFECT BOAT. We go bluewater fishing, 25-40+ miles offshore, and this is a great ride, just right. The layout complements our fishing and we feel it's the safest boat on the water. Cooper, our lab retriever, pouts for days if he's left at the dock!" —Rick and Jackie Owens. Ft. Lauderdale, FL, *Bimini* owners

30' CENTER CONSOLE

# BIMINI 306

- Beam Amidships: 10'7"
- Bridge Clearance: 7'3"  
w/T-Top: 8'9"
- Center Line Length: 30'6"
- Length Overall (w/pulpit): 32'7"
- Cockpit Depth: 27"
- Cockpit Square Footage: 75 sq. ft.
- Hull Draft: 19"
- Maximum HP: 600
- Outboard Shaft Length: 25"
- Standard Fuel Capacity: 306 gal.
- Transom Width: 9'6"
- Weight w/o Engine: 6500 lb.



## STANDARD FEATURES

### Safety

- 2 automatic bilge pumps (total 2950 GPH)
- Basic flotation
- Bow rail - low profile 316 grade stainless steel
- Chrome-over-bronze through-hull fittings
- Cockpit toe rails
- Console grab rail
- Nonskid fiberglass liner
- Self-bailing cockpit w/4 cockpit drains

### Cockpit & Deck

- 100% hand laid hull & deck
- Anchor windlass wiring
- Battery select switch
- Casting platform (raised)
- Cockpit bolsters
- Cockpit lights
- Cockpit shower (recessed)
- Cutting board
- Deck hardware - 316 grade stainless steel through-bolted
- Drink holders (2)
- Factory engine pre-rigging
- Fish box - 64-qt. port & starboard insulated fish boxes w/ob drain
- Fish box - 352-qt. center insulated fish box w/ob drain

- Fuel capacity - 306 gallons (150-gallon tank, 156-gallon tank)
- Heavy-duty gunwale molding
- Hydraulic trim tabs
- Integrated outboard mounting system w/swim platform & ladder
- International lighting
- Livewell - 41-gallon aft deck insulated raw water livewell w/light, full column distribution inlet & ob drain
- Rigging station - lean bar station w/two 21-qt. insulated bait boxes & freshwater sink w/pull out faucet
- Rod holders (4)
- Rod storage - lockable horizontal storage for 6 rods
- Seating - deluxe lean bar w/footrest, backrest, tackle trays, lockable storage & rod holders (6)
- Spring line cleats
- Stern eyes
- Storage - forward anchor locker w/rope storage
- Storage nets
- Transducer mounting flats
- Transom door
- Washdown - pressurized raw water w/hose
- Water tank - 32-gallon freshwater

### Console

- Accessory outlet - 12V (2)
- Compass

- Console ventilator
- Drink holders (4)
- Head - lockable console w/stand up head area, shower, sink, storage compartments, bulk storage & hanging locker
- Head - marine head w/macerator, 10-gallon holding tank & pump out
- Seating - molded forward console seat w/cushion
- Steering - hydraulic tilt
- Steering wheel - 316 grade stainless steel
- Storage - electro-mechanically operated electronics enclosure
- Storage - lockable acrylic console door
- Storage - under footrest
- Windshield - Plexiglas windshield w/handrail

## OPTIONAL FEATURES

- Anchor windlass
- Bow pulpit (includes high profile bow rail)
- Convenience package #1 - Battery charger & dockside power w/galvanic isolator
- Convenience package #2 - Casting platform cushions, forward bolsters & fold away aft bench seat w/cushion
- Head - marine head w/electric flush (10-gallon)
- Outrigger kit - 15-ft. Radial Top Gun T-Top mounted

- Stereo/CD system
- T-top w/radio box, dome light, storage net & spreader lights

## Canvas Options

- T-top front & side curtains

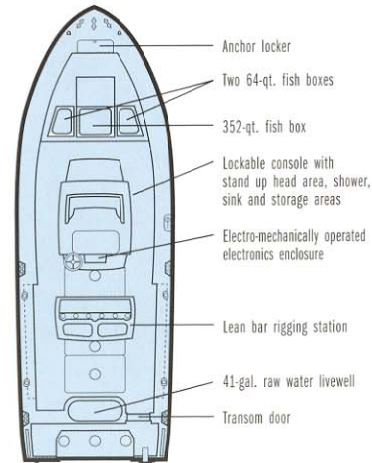

Lockable head enclosure with sink, shower and storage



41-gallon raw water aft deck livewell



Deluxe lean bar w/footrest, backrest, tackle trays, lockable storage & rod holders

## CUSTOMER-IZATION



## SHORT, TALL, BIG OR SMALL—THESE ELECTRONICS CAN BE READ BY ALL.

Fishermen come in all sizes. And even in low light conditions—morning and evening when fishing is best—fishermen must be able to read the electronics to be safe and successful. The *Bimini 306* electro-mechanical electronics enclosure adjusts both to varying viewing conditions and to the helmsman's height at the push of a button.







"ONE GREAT SEA BOAT! The ride floors me—it is as good or better than that of a 33'-36' inboard." —Kirk Carter, Greenville, SC, EXPRESS 330 owner

33' EXPRESS CABIN

# EXPRESS 330

- Beam Amidships: 11'7"
- Bridge Clearance w/Hardtop: 9'10"
- Center Line Length w/o pulpit: 33'6"
- Length overall (w/pulpit): 35'10"
- Cockpit Depth: 29"
- Cockpit Square Footage: 80 sq. ft.
- Hull Draft: 21"
- Maximum HP: 600
- Outboard Shaft Length: 25"
- Standard Fuel Capacity: 350 gal.
- Transom Width: 10'6"
- Weight w/o Engines: 10,000 lb.  
(includes all standard features)

## STANDARD FEATURES

### Safety

- 2 automatic bilge pumps (total 2950 GPH)
- Basic flotation
- Bow rail - 316 grade stainless steel
- Chrome-over-bronze through-hull fittings
- Cockpit toe rails
- Companion grab rail
- Nonskid fiberglass liner
- Self-bailing cockpit w/4 cockpit drains

### Cabin

- Accessory outlet - 12V
- Air conditioning
- Berth - aft double berth
- Berth - forward vee berth
- Cabin lights
- Flatscreen TV w/DVD player
- Forward hatch - two low profile acrylic hatches w/screen
- Forward hatch curtains
- Galley - port side galley w/sink
- Head - enclosed ventilated head area w/sink, shower & lamps
- Head - storage cabinet
- Head - VacuFlush™ marine head (10-gallon)
- Lockable door w/screen & companionway hatch
- Microwave oven

- Mirrors
- Refrigerator
- Rod storage racks
- Stereo/CD system
- Storage - galley cabinets
- Storage - under berth compartments
- Storage nets
- Stove - electric glass top
- Teak & holly floor
- Teak table
- Water heater - 6-gallon, 120V
- Water tank - 50-gallon freshwater

### Cockpit & Deck

- 100% hand laid hull & deck
- Accessory outlet - 12V (2)
- Anchor windlass
- Batteries (4)
- Battery charger system
- Battery select switch
- Bow pulpit w/roller
- Cockpit bolsters
- Cockpit lights
- Cockpit shower (2)
- Compass
- Deck hardware - 316 grade stainless steel through-bolted
- Dockside power w/galvanic isolator
- Drink holders (7)
- Dynaplate
- Factory engine pre-rigging
- Fighting chair reinforcement
- Fish box - 270-qt. aft deck insulated fish box w/ob drain
- Footrest - helm (adjustable)
- Footrest - aft facing seats
- Fuel capacity - 350 gallons (150-gallon tank, 200-gallon tank)



- Generator (gas)
- Hardtop w/radio box, storage net, spreader lights, rod holders (6) & canvas
- Heavy-duty gunwale molding
- Hydraulic trim tabs
- Integrated outboard mounting system w/swim platform & ladder
- International lighting
- Livewell - 45-gallon starboard insulated raw water livewell w/light, full column distribution inlet & ob drain
- Rigging station w/freshwater sink & pull out faucet
- Rod holders - gunwale (4)
- Rod storage racks - horizontal (4)
- Seating - fold away aft bench seat w/cushion
- Seating - helm area surround seat w/removable backrests
- Seating - vertically & horizontally adjustable deluxe helm chair
- Spring line cleats
- Steering - hydraulic tilt
- Steering wheel - 316 grade stainless steel
- Stern eyes
- Storage - aft deck lift out box
- Storage - electro-mechanically operated electronics enclosure
- Storage - forward anchor locker w/rope storage
- Storage - under helm area surround seating
- Storage nets
- Transom door
- Washdown - pressurized raw water w/hose

- Windshield - ventilated windshield
- Windshield washer - freshwater
- Windshield wiper

## OPTIONAL FEATURES

- Bow thruster
- Generator (diesel)
- Outrigger kit - 19-ft. Lee Jr. cabin side mounted
- Outrigger kit - 24-ft. Lee Pro Series (lay out)

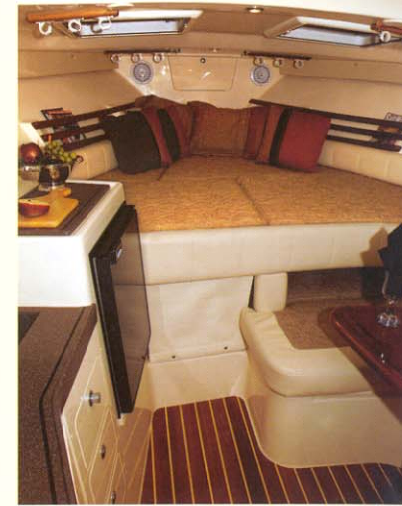
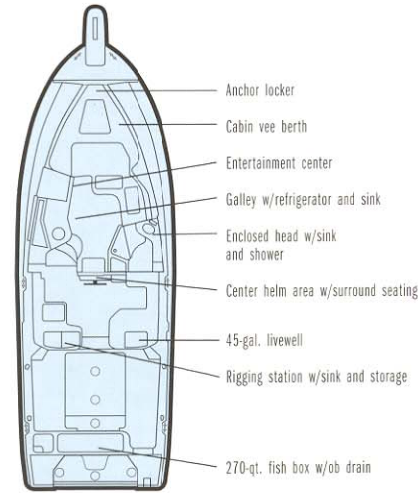

Cabin interior with teak and holly floor



Helm area surround seating with removable backrests



Helm station with electro-mechanically operated electronics enclosure



Flatscreen TV with DVD player

## CUSTOMER-IZATION



## THE BIGGEST (AND BEST) BOAT CREATED FOR TODAY'S MODERN OUTBOARD POWER.

The input process that resulted in our EXPRESS 330 was, at the time, the most intensive customer-ization effort we'd undertaken. The result? *Boating Magazine's* 2001 Boat of the Year. "The range, fuel economy, comfort, and fishing and cruising abilities of any serious inboard sportfish of comparable length...has also the speed, interior volume, running angle and ease of use of an outboard."





Hardtop with net storage, electronics enclosure and rod holders



Port helm seating area features a folding seat and insulated ice box



Starboard helm seating features a folding seat



Cabin interior featuring galley and entertainment center with flatscreen TV and DVD



Port side tackle station and sink



Detail of cabin flooring



Head enclosure with Corian® countertops and extendable shower faucet



270-qt. aft deck insulated fish box; fold away aft bench seat with cushion



Cabin interior showing access to roomy aft berth

33' EXPRESS CABIN

# EXPRESS 330

*"AFTER RESEARCHING THE MARKET FOR THE LARGEST, MOST SEAWORTHY OUTBOARD POWERED BOAT... the Express 330 was our choice, especially after it passed my 6'4" head clearance test."*

—Klaus Priebe, Barbados, *Express 330* owner

The *Express 330* was created as the flagship of the Grady-White fleet, with exceptional and unprecedented input from customers. From its debut in model year 2001, when it was named *Boating Magazine's* Boat of the Year, the 330 has been making waves.

Klaus and Mary Priebe live in Barbados, where routinely the



winds run 25 MPH and seas five to ten feet. "After researching the market for the largest, most seaworthy outboard powered boat, Grady-White topped the list. At a Fort Lauderdale Boat Show we confirmed that an *Express 330* was our choice, especially after it passed my 6'4" head clearance test," wrote Klaus Priebe.

Their boat was shipped by freighter to St. Lucia, which is 100 miles across the open Atlantic to Barbados. The Priebes set for home at 6 P. M., averaging 15 MPH in the true-to-form brisk wind and seas. "I said to my wife, thank heavens it's pitch dark because if we had been able to see the waves they'd have scared us," recounts Priebe. "But in that entire six-hour run we felt safe, the boat performed perfectly, and the ride of the boat felt as if on shock absorbers. What a hull!"

In Barbados, the Priebes always have family and friends aboard. "We haven't had a problem since launching. The kids' only complaint is about Dad's choice of music!"









▲ Hardtop front and side curtains for models 20' and up (drop curtain is available)



▲ Hardtop with lockable radio boxes, spreader lights, side rod holders and overhead storage net (for models 22' and up)



▲ 208 Hardtop with lockable radio box, spreader lights and rod holders



▲ Bow thruster (300, 330)

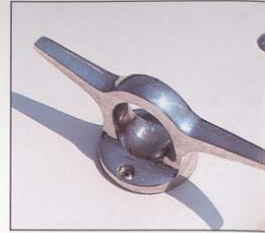

▲ Bow lifting ring



▲ Jump seat (222)



▲ Tournament series sleeper seat with storage

# Factory options add to the enjoyment of your Grady Life.



▲ Raw water washdown w/coil hose (location varies by model)



▲ Freshwater cockpit shower (location varies by model)



▲ Large swim platform



▲ Small swim platform



▲ 273 Bow casting platform insert with removable cushions



▲ Bow pulpit shown with anchor windlass option



▲ Stereo w/helm mounted keypad



▲ Dockside power (part of a convenience package)





Companion bench seat (300 shown)



▲ Cabin rod racks



▲ Raw water livewell (lean bar option) (209, 222)



▲ Outrigger kit, cabin side mounted (300, 330)

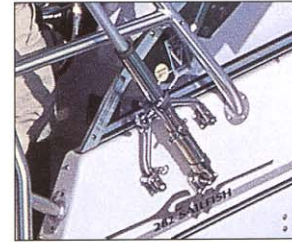

▲ Outrigger kit, cabin side mounted (232, 265, 270, 282)



Deluxe helm chair



▲ Forward bolsters (185, 205)



▲ Trim tabs



▲ Outrigger kit, Radial Top Gun T-top Mounted

**FACTORY RIG YOUR CHOICE OF YAMAHA OUTBOARD** Grady-White can provide factory pre-rigging so engine controls, wiring and instrumentation are installed while your boat is built. Grady-Built quality ensures that your engine installation delivers optimum performance. We stand behind our work: pre-rigging is covered under Grady-White's factory warranty.



Walkaround series vista top and side curtains (208, 226/228, 232, 258, 270)



▲ Center console Bimini top (180, 209, 222)



▲ Tournament series vista top



▲ Portable head



▲ Head with holding tank



**Anchor locker** with rope storage

**Safety glass windshields**

**Grab rails are at your fingertips** at the helm, in the cockpit, walkaround area and when you climb back onboard after a swim.

**Solid 100% hand laid hulls and decks** provide uniform laminate structure, strength and durability.

**Through-bolted upright rod holders** are chrome-over-bronze.

**Stainless steel screws and blindside fasteners** join the hull and liners to the deck with polyethylene gaskets sealed not only with silicone but with a powerful bonding adhesive developed for the aerospace industry.

**Liner is bonded** to the stringer system and hull with fiberglass.

**All Grady-Whites have foam sprayed into the hull** for level (models 180, 185) or basic flotation, even though not required in boats over 20 feet. This foam also adds strength, thermal insulation and deadens sounds. There is no boat brand with better flotation properties.

**No-rot stringer system** is encapsulated in resin and fiberglassed to the hull.

**Protected rigging** with factory installed PVC tubing

**Through-bolted 316 stainless steel hardware** is secured with locking nuts.

**Yamaha engine pre-rigging** is installed at the factory and custom fitted to your boat.

**BOAT SMART FROM THE START;** take a boating safety course and get a free vessel safety check for your boat. For more information contact: United States Coast Guard Auxiliary, 1.800.368.5647, [www.cgau.org](http://www.cgau.org), or United States Power Squadrons, 1.888.for.usps, [www.usps.org](http://www.usps.org).

**Double through bolting** on threshold of cabin

**Adjustable seats** have integrated hand holds.

**Storage is engineered for functionality.** We aim to ensure that Grady-Whites have the most storage of any boat in their category.

**Insulated fish boxes and ice boxes** are above the waterline and drain overboard, never into the bilge. Gutter systems are built into all exterior storage spaces.

**Nonskid self-bailing cockpit** directs water overboard whether at rest or underway. All scuppers drain overboard. Inspection ports are watertight. All Grady-Whites have automatic bilge pumps, with two pumps on most models over 20 feet. Our dedication to self-bailing cockpit integrity is unparalleled.

**Toe rails** secure your feet when you lean over the side.

**Weather resistant polyethylene rod racks**

**Solid fiberglass transom door** is not just for big fish, but adds easy access and safety too. Solid, 316 stainless transom door hardware is highlighted by a destroyer-sized latch with a positive locking mechanism for added safety.

**Swim ladder** is designed in every detail for ease of boarding and is super strong 316 stainless steel for safety.

**5/16" aluminum transom brace** is bonded to the top of outboard transoms, which reinforces transom strength and distributes motor torque. On integrated bracket models, the brace is through bolted to the longitudinal stringer system.