



Grady-White 2002



Hi! We are so pleased you are considering a Grady-White boat. We hope to prove to you personally that everything you have heard about the

Grady-White handcrafted tradition is true: We build tough, superbly engineered offshore sportfishing boats. A Grady-White delivers confidence, quality, safety and lasting value.

The number one key to your satisfaction is your Grady-White dealer. Our dealerships and the men and women who run them are tops in the business. To enjoy the privilege of selling

exceeds your expectations.

Grady-White can deliver a superior boat and buying experience because of the people behind the product. Our company's private ownership, long-term leadership, and expert craftsmen have allowed us to focus exclusively on building the best, and we enjoy an excellent reputation around the world. Our limited production structure and close contact with the people who buy our boats allow us to fine-

events and the growing network of Grady-White owners' clubs, through our very special owners' forums, with customer tours of our plant (you're invited!), and with the *Anchorline* newsletter and our website. We really do listen!

Never compromise your safety.

Every Grady-White customer demands safety first. Since we began building boats in 1958, Grady-White safety and seaworthiness have

sense the solid, heavyweight construction every time you step aboard. That's why Grady-White owners trust their boats to take them on great adventures, and to bring them safely back to home port.

You are the design inspiration.

With 18 models including 19' and 22' dual consoles, center consoles from 18' to 30', and cabin boats from 20' to 33', Grady-White is the marine industry's full-line builder of small offshore sportfishing boats. There's a Grady-White that's exactly right for you.

Grady-Whites are engineered foremost



Eddie Smith
and Kris Carroll



Grady-White pioneered the walkaround and experience delivers a better value.

A Grady-White is an enduring symbol of safety, true sportsmanship, and people who enjoy the best in fishing and boating.

Grady-White boats, your dealer must be exemplary in customer satisfaction and have superior product knowledge that

tune details to an exceptional degree. We actively encourage customer interaction through dealer tournaments and

become legendary. Today we combine the best of handcrafted tradition with modern materials and building techniques.

by people who fish, *for* people who fish, so you'll find huge fish boxes, open cockpits, and plenty of rod and tackle storage.

“Safety is very important and is one of the reasons we bought the boat. That and Grady's reputation.”

—Roger and Diane Stanton, *Express 330* owners

Every hull and deck has 100% hand laid fiberglass for maximum strength and durability. Every single model is absolutely unsinkable: foam flotation is hand sprayed into the hull, deck and liner. You

High gunwales, transom doors, bolsters and toe rails make other family activities and water sports safer and more enjoyable, too. Many Grady features and details began with customer ideas such as



Grady clubs and “Grady Bunches” plus owners' tournaments, cruises and get-togethers add to the fun of owning a Grady-White.



Clutter is the enemy of safe operation, so Grady-White takes advantage of every storage opportunity. Storage on a Grady is everywhere you look. It's convenient and secure.

incorporating heads in center consoles, and creating storage opportunities in useful places. We encourage owners to tell us what works best in their experience, and what improvements can be made to make their boating even better. This process is why a Grady-White boat is engineered not only for exceptional performance, it is built for years of fun and comfort.

can be easily read by the helmsman. We've engineered easier access to equipment, and to oil and gas fills that makes fueling faster and cleaner. Improvements like these are why a Grady-White is a safer boat, and they make

maintenance and operation a breeze, so your Grady days on the water are long, happy and relaxing ones.

“Our boat is splendid. Very well thought out for fishing; great rough water ride.”

—Patric Bryan, *Adventure 208* owner

Every boat in our line has new features, and two models are new or completely revamped. There's the new flagship of our fleet, the *Express 330* — the biggest Grady-White ever. This express cabin

model has more stay-aboard cabin amenities, a wide open cockpit for blue-water fishing, and a helm area with surround seating for delightful cruising. The center console *Chase 273* has a new deck and liner with new lockable rod storage



With 18 models from the 18' *Sportsman 180* to the new 33' *Express 330*, Grady-White is the industry's full-line builder of small sportfishing boats. There's a Grady-White just right for you and your family.

that can stow a 9' fly rod, and a big aft fish box and livewell. The console and lean bar are remodeled, and there's now

a special fold-away aft seat. Our *Fisherman 222* has a great new console area including a head, and with all around improvements our popular 27' walkaround has been renamed the *Islander 270*.

Freedom to relax and enjoy.

A Grady-White is more than a boat. It is a symbol of smart people who invest in the freedom to relax and enjoy great adventures and good sportsmanship. We are dedicated to your being exceedingly happy when you make the decision to come aboard.

Happy boating!

Eddie Smith, chairman and CEO

Kris Carroll, president

We only get better.

A great reputation must be continually earned. Our consistent quality is why Grady-White owners are so loyal and that our boat resale values are so high. Customers over time have owned four, five, six, even twelve Grady-Whites. This year's innovations will undoubtedly further their appreciation for Grady-White detail.

Across the line we've upgraded bow lights for better visibility of your Grady in low light or fog. Our backlit switches

Grady-Built means engineering excellence.

Sound structural integrity is the key to a tough, safe, long lasting boat, and durable boats keep their resale value.



Every hull is a Grady-White SeaV² exclusive design by C. Raymond Hunt Associates, the originators of the modified deep vee. These SeaV² designs provide top performance in ride and efficiency. All Grady-White boats have self-bailing cockpits—all decks and boxes drain directly overboard by the force of gravity, and not into a bilge or sump. We through-bolt our super strong transoms

are everywhere you are likely to step, and handholds are placed wherever you are likely to reach. The term Grady-Built means we construct such security into our boats that even a first time boater feels confident in a Grady.

Grady-Built means the finest materials.

Grady-White boats are built with quality materials that have been tested and retested for value and security. We use the right laminates in the right places to assure durability. Our 316 grade stainless steel hardware is superior in strength to the industry standard 306, and resists corrosion in a saltwater environment.

“We love owning a Grady-White.”

—John and Shelly McKee, *Fisherman 222* owners

trim work and toe rails will look good as new in years to come. Our cabins are appointed with durable fabrics and dependable fixtures and appliances.

Grady-Built means the ultimate fit and finish.

Attention to detail is a part of the Grady-White culture: we focus on “getting things right” from the boat concept stage to the completion of every production model. From the CEO and president to



J.D. Power and Associates ranks* Grady-White:

Highest in Customer Satisfaction with Center Console Boats

Center Console Boats include Dual Console, Center Console, and Walkaround Boats.

Marine Advisory: Get the Grady.

Grady-Whites are Grady-Built for long-term performance and security in the toughest conditions.

to our no-rot stringers and encapsulate them in resin, then fiberglass them to the hull for exceptional strength. We make maximum use of cockpit space with raised boxes that keep decks clear for safety and maneuverability. Storage opportunities abound. Nonskid surfaces

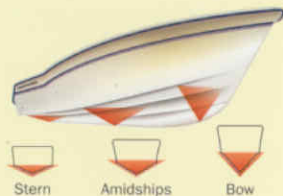

Grady's exclusive SeaV² hull is like a series of wedges: flatter aft for stability at rest or trolling, and sharper at the bow for sea-cutting power at speed.

UV resistant chrome-over-bronze through-hull fittings are double clamped for an extra measure of safety. Fish and ice box lids, hardtops and bow pulpits are resin transfer molded fiberglass, making surfaces smooth and easy to clean. Extra-durable polyethylene



SeaV² chines knock down spray for a drier ride. Notice three distinct wakes when the boat is on plane. That's a SeaV² hallmark.

the newest employee, our management and craftsmen know that “good enough” just isn't good enough at Grady-White. That's why Grady-White boats enjoy a very high level of customer satisfaction for fit and finish. Our exacting attention to detail is part of why so many Grady-White customers love their boats and will always own a Grady.

Grady-Built means more satisfaction.

The J.D. Power and Associates 2001

“We are completely happy.”

—David Rothe & Linda Jannelle, *Sailfish 272* owners

Marine Quality and Performance StudySM provides an unbiased assessment of consumer-reported boat quality and performance in three categories including bass boats, runabouts, and center console boats. (In the study, center console boats include dual console, center console and walkaround boats.) Out of 13 companies included in the center console segment, Grady-White Boats was ranked Highest in Customer Satisfaction with Center Console Boats.*

*Ranking resulted from J.D. Power and Associates 2001 Marine Quality and Performance StudySM. Study based on responses from a total of 5,979 owners of 2000 model-year boats. www.jdpower.com

Grady-White: a leading steward of aquatic resources

The study looked at sales and service experience, product quality, features and controls, ride and handling, comfort and convenience, and engine performance. We are proud of this J.D. Power and Associates distinction. We believe it is an indication of how we work very hard to ensure you will be happy with each phase of your Grady-White experience. Visit www.gradywhite.com "What's New" for more information.

Grady-Built means better built.

From stem to stern, a Grady-White

At Grady-White, conservancy is a guiding principle. Perhaps more than any other boat brand, a Grady-White is a symbol of sportsmanship and commitment to aquatic resources.

Grady-White Boats owner and CEO Eddie Smith, Jr., has been the guiding force behind this unique commitment. In 2001, Eddie Smith received the first-ever lifetime achievement award from the American Sportfishing Association (ASA), and special recognition from the

Recreational Fishing Alliance, North Carolina Aquariums, and many more local and regional environmental, education and conservation oriented organizations. Grady dealerships and plant employees have also made long-term contributions of time and money to boating and boating safety organizations, and to environmental education, conservation and fisheries



Tampa Bay Grady-White Owners Club members enjoy a sea turtle recovery and release project.

example, our new gas and oil fills mean cleaner, safer fueling; our storage spaces and drink holders help keep trash in the boat and out of the waterways. We have also been instrumental in working with Yamaha in developing

and testing their cleaner, quieter, more efficient HPDI and 4-stroke engines. We firmly believe that a better engineered boat is not only safer, but contributes to



gives you years of service and the peace of mind to enjoy the pleasures of offshore recreation. In sportfishing ports and on the water the world over, the unmistakable look of a Grady-White signals, even from a distance, that the owner has chosen the ultimate in outboard boating and fishing fun. These owners know that the best advice is to have the strongest, best engineered and safest boat available. That's why they got the Grady! They know Grady-Built means better built. Join them!

International Game Fish Association (IGFA) for his contributions to sportfishing. Smith also serves on the boards of IGFA, the Sportfishing and Boating Partnership Council, the Recreation Roundtable, and the University of North Carolina Educational Foundation. He and Grady-White are also active in The Billfish Foundation, Coastal Conservation Association, Fish America Foundation, the



Eddie Smith received the American Sportfishing Association's first-ever Lifetime Achievement Award.

management at every level.

The contributions that Grady-White people make go beyond leadership in groups and organizations. We regularly promote conservation and catch and release practices in our *Anchorline* newsletter. We promote catch and release fishing tournaments and the fun of fishing at our dealer tournaments and get-togethers. Our very design and engineering contributes to better stewardship: for

a better environment.

In addition, Grady-White was one of the first to actively help with the successful Tag-a-Giant program of archival and pop-up tagging of giant bluefin tuna, which has vastly expanded our knowledge of and ability to manage this incredible species. Grady-White, Grady-White dealers and especially Grady-White owners are committed to true sportsmanship and enjoying the best in fishing and boating.



GRADY-WHITE

YAMAHA

Beam Amidships: 7'5"
Bridge Clearance: 5'7"
Center Line Length: 17'10"
Cockpit Depth: 22"

Cockpit Square Footage: 48 sq. ft.
Hull Draft: 14"
Maximum HP: 150
Outboard Shaft Length: 25"

Standard Fuel Capacity: 60 gal.
Transom Width: 7'2"
Weight w/o Engine: 1800 lb.

Standard Features

Safety

Automatic bilge pump (1250 GPH)
 Bow rail - low profile 316 grade stainless steel
 Chrome-over-bronze through-hull fittings
 Cockpit toe rails
 Console grab rail
 Level flotation
 Nonskid fiberglass liner
 Self-bailing cockpit w/2 cockpit drains

Cockpit & Deck

100% hand laid hull and deck
 Casting platform (raised)
 Deck hardware - 316 grade stainless steel through-bolted
 Drink holders (2)

Fish box - 89-qt. insulated fish box/storage area w/ob drain
 Fuel capacity - 60-gallon tank
 Heavy-duty gunwale molding
 International lighting
 Rod holders (4)
 Rod storage racks - 4 horizontal
 Seating - bench seat w/reversible back
 Seating - 2 aft seats
 Stern eyes
 Storage - 2 aft rigging compartments
 Storage - forward anchor locker w/rope storage

Console

Accessory outlet (12V)
 Cellular phone holder
 Fish box - 45-qt. forward insulated fish box w/ob drain
 Footrest

Rod storage holders - 4 vertical
 Seating - forward console seat
 Steering - no-feedback mechanical
 Steering wheel - 316 grade stainless steel
 Storage - lockable console storage
 Storage - lockable electronics box
 Storage net
 Windshield - Plexiglas windshield w/handrail

Optional Features

Battery select switch w/extra battery
 Bow lifting ring
 Cockpit shower w/10-gallon freshwater tank

High bow rail
 Hydraulic trim tabs
 Livewell - 45-qt. insulated raw water livewell
 Seating - forward platform cushions
 Steering - hydraulic
 Steering - tilt
 Swim platform w/ladder

Canvas Options

Bimini top w/boot
 Console cover

18' CENTER CONSOLE

Sportsman 180

"The entire family always appreciates the safety and security on the commute to our island home." —Dwight Brew, *Sportsman* owner



Bow casting platform



Forward console seating with optional livewell

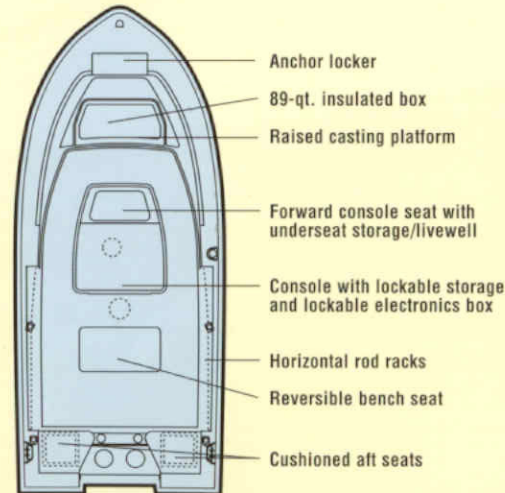

Console with lockable storage and electronics box



GRADY-WHITE

YAMAHA

Beam Amidships: 8'
Bridge Clearance: 4'9"
Center Line Length: 19'2"
Cockpit Depth: 25"

Cockpit Square Footage: 37 sq. ft.
Hull Draft: 14"
Maximum HP: 200
Outboard Shaft Length: 25"

Standard Fuel Capacity: 60 gal.
Transom Width: 7'8"
Weight w/o Engine: 2075 lb.

Standard Features

Safety

Automatic bilge pump (1250 GPH)
 Bow rail - low profile 316 grade stainless steel
 Chrome-over-bronze through-hull fittings
 Cockpit toe rails
 Companion grab rail
 Level flotation
 Nonskid fiberglass liner
 Self-bailing cockpit w/2 cockpit drains

Cockpit & Deck

100% hand laid hull and deck
 Accessory outlet (12V)
 Cockpit lights
 Cutting board

Deck hardware - 316 grade stainless steel through-bolted
 Drink holders (6)
 Fuel capacity - 60-gallon tank
 Heavy-duty gunwale molding
 Integrated outboard mounting system
 w/swim platform and ladder
 International lighting
 Rod holders (4)
 Rod storage racks - 6 horizontal
 Seating - starboard pedestal chair
 Seating - port sleeper seat
 Seating - 2 aft seats
 Seating - bow cushions
 Spring line cleats
 Steering - no-feedback mechanical
 Steering wheel - 316 grade stainless steel

Stern eyes
 Storage - forward anchor locker w/rope storage
 Storage - port bow seat compartment
 Storage - 44-qt. starboard insulated ice box w/ob drain
 Storage - lockable electronics box
 Storage - lockable glove box
 Storage - 2 lockable console storage compartments
 Storage net
 Windshield - walk-through windshield
 Windshield wiper (starboard)

Optional Features

Battery select switch w/extra battery
 Bow lifting ring

Cockpit shower w/10-gallon freshwater tank
 Livewell - 53-qt. insulated raw water livewell w/cushion
 Seating - bow seat back cushions
 Seating - deluxe helm & companion chairs
 Seating - starboard sleeper seat
 Steering - hydraulic
 Steering - mechanical tilt

Canvas Options

Aft curtain
 Bow cover
 Vista top w/side curtains & boot

19' DUAL CONSOLE

Tournament 192

"I feel very confident taking my family out on the water."

—David Beliakoff, *Tournament 192* owner



Helm area w/lockable console storage

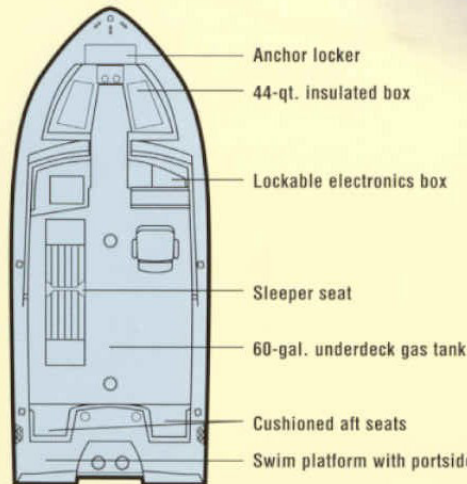

Bow seating with cushions and optional bow seat back cushions



Cockpit forward with standard port and optional starboard sleeper seats



GRADY-WHITE

YAMAHA

200

Beam Amidships: 8'1"
Bridge Clearance: 5'9"
w/Hardtop: 8"
Center Line Length: 20'4"

Cockpit Depth: 25"
Cockpit Square Footage: 41 sq. ft.
Hull Draft: 14"
Maximum HP: 230

Outboard Shaft Length: 25"
Standard Fuel Capacity: 82 gal.
Transom Width: 7'10"
Weight w/o Engine: 2650 lb.

Bow pulpit
 Cockpit bolsters
 Cockpit shower w/10-gallon freshwater tank
 Hardtop w/radio box & spreader lights
 Hardtop rod holders
 Head - portable
 Head - portable w/deck pump out
 Hydraulic trim tabs
 Livewell - 103-qt. insulated raw water livewell
 Steering - hydraulic
 Steering - tilt
 Swim platform w/ladder
 Washdown - pressurized raw water w/hose

Standard Features

Safety

Automatic bilge pump (1250 GPH)
 Basic flotation
 Bow rail - 316 grade stainless steel
 Chrome-over-bronze through-hull fittings
 Cockpit toe rails
 Companion grab rail
 Fold down motorwell bulkhead
 Nonskid fiberglass liner
 Nonskid recessed walkaround
 Self-bailing cockpit w/4 cockpit drains

Cabin

Berth - forward vee berth
 Cabin light
 Forward hatch - low profile acrylic hatch w/screen
 Lockable door w/screen & companionway hatch
 Rod storage holders (4)

Storage - portable head compartment
 Storage - under berth compartments (3)
 Windows - opening windows w/screens (2)

Cockpit & Deck

100% hand laid hull and deck
 Accessory outlet (12V)
 Cockpit lights
 Deck hardware - 316 grade stainless steel through-bolted
 Drink holders (4)
 Fish box - 103-qt. port insulated fish box w/ob drain
 Fish box - 106-qt. starboard insulated fish box w/ob drain
 Footrests (helm & companion)
 Fuel capacity - 82-gallon tank
 Heavy-duty gunwale molding
 International lighting
 Rod holders (4)
 Rod storage racks - 6 horizontal
 Seating - 2 pedestal chairs

Seating - 2 aft seats
 Seating - foredeck cushions
 Seating - port & starboard fish box cushions
 Spring line cleats
 Steering - no-feedback mechanical
 Steering wheel - 316 grade stainless steel
 Stern eyes
 Storage - aft seat lift out boxes (2)
 Storage - forward anchor locker w/rope storage
 Storage - lockable electronics box
 Storage - lockable storage under helm chair
 Storage nets
 Storage - tackle drawers under companion chair (2)
 Windshield
 Windshield wiper (starboard)

Optional Features

Bow lifting ring

Canvas Options

Drop curtain (hardtop or vista top)
 Hardtop front & side curtains
 Helm station cover
 Vista top w/side curtains & boot



20' WALKAROUND CABIN

Adventure 208

"Your attention to detail is well beyond any other company we've ever dealt with." —Ted & Ruth Weissberger, *Adventure* owners



Helm station

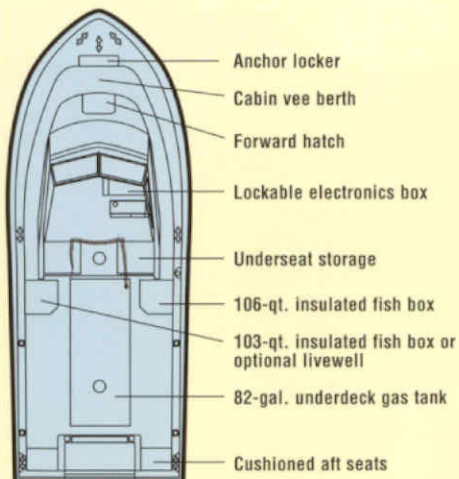

Cockpit forward



Cabin interior shown without auxiliary berth cushion



YAMAHA

GRADY-WHITE

Beam Amidships: 8'1"
Bridge Clearance: 5'9"
w/T-top: 7'8"
Center Line Length: 20'4"

Cockpit Depth: 25"
Cockpit Square Footage: 51 sq. ft.
Hull Draft: 14"
Maximum HP: 230

Outboard Shaft Length: 25"
Standard Fuel Capacity: 82 gal.
Transom Width: 7'10"
Weight w/o Engine: 2450 lb.

Standard Features

Safety

Automatic bilge pump (1250 GPH)
 Basic flotation
 Bow rail - low profile 316 grade stainless steel
 Chrome-over-bronze through-hull fittings
 Cockpit toe rails
 Console grab rail
 Fold down motorwell bulkhead
 Nonskid fiberglass liner
 Self-bailing cockpit w/2 cockpit drains

Cockpit & Deck

100% hand laid hull and deck
 Casting platform (raised)
 Cockpit lights
 Deck hardware - 316 grade stainless steel through-bolted

Fish box - 83-qt. port insulated fish box w/ob drain
 Fish box - 120-qt. starboard insulated fish box w/ob drain
 Fuel capacity - 82-gallon tank
 Heavy-duty gunwale molding
 International lighting
 Rod holders (4)
 Rod storage racks - 6 horizontal
 Seating - 2 pedestal chairs
 Seating - 2 aft seats
 Spring line cleats
 Stern eyes
 Storage - forward anchor locker w/rope storage
 Storage - 2 aft rigging compartments

Console

Accessory outlet (12V)
 Drink holders (2)
 Livewell - 28-gallon forward insulated raw water livewell w/ob drain

Rod storage holders - 6 vertical
 Seating - forward console seat w/cushion
 Steering - no-feedback mechanical
 Steering wheel - 316 grade stainless steel
 Storage - lockable electronics box
 Storage - 2 lockable storage compartments
 Windshield - Plexiglas windshield w/handrail

Optional Features

Bow lifting ring
 Cockpit bolsters
 Cockpit shower w/10-gallon freshwater tank
 High bow rail
 Hydraulic trim tabs

Livewell (lean bar option only) - 23-gallon insulated raw water livewell w/cushion
 Seating - forward platform cushions
 Seating - bench seat w/reversible back
 Seating - lean bar w/backrest, footrest, tackle trays, lockable storage & 4 rod holders
 Steering - hydraulic
 Steering - tilt
 Swim platform w/ladder
 T-top w/rod holders, radio box, dome light, storage net & spreader light
 Washdown - pressurized raw water w/hose

Canvas Options

Bimini top w/boot
 Console cover
 T-top front & side curtains



20' CENTER CONSOLE

Escape 209

"Everything is accessible—electronics, anchor, washdown, motorwell." —Adrian and Elizabeth French, *Escape* owners



Insulated bow fish boxes



Cockpit forward with optional leanbar & T-top

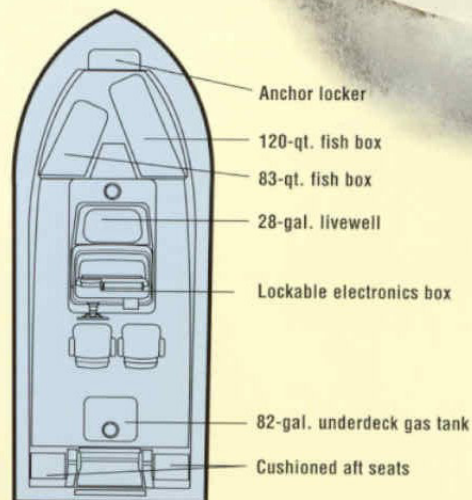

Aft seating with fold down motorwell bulkhead



GRADY-WHITE

YAMAHA

FOUR STROKE

225

Beam Amidships: 8'
Bridge Clearance: 6'2"
w/T-top: 8'
Center Line Length: 22'2"

Cockpit Depth: 25"
Cockpit Square Footage: 55 sq. ft.
Hull Draft: 15"
Maximum HP: 250

Outboard Shaft Length: 25"
Standard Fuel Capacity: 96 gal.
Transom Width: 7'11"
Weight w/o Engine: 3160 lb.

Standard Features

Safety

Automatic bilge pump (1700 GPH)
 Basic flotation
 Bow rail - low profile 316 grade stainless steel
 Chrome-over-bronze through-hull fittings
 Cockpit toe rails
 Console grab rail
 Fold down motorwell bulkhead
 Nonskid fiberglass liner
 Self-bailing cockpit w/4 cockpit drains

Cockpit & Deck

100% hand laid hull and deck
 Casting platform (raised)
 Cockpit lights
 Deck hardware - 316 grade stainless steel through-bolted
 Fish box - two 55-qt. insulated fish boxes w/ob drain
 Fish box - 272-qt. center insulated fish box w/ob drain

Console

Accessory outlet (12V)
 Drink holders (2)
 Head - lockable console w/stand-up head area & storage
 Rod storage holders - 6 vertical
 Seating - forward console seat w/cushion
 Steering - hydraulic tilt
 Steering wheel - 316 grade stainless steel
 Storage - lockable electronics box
 Storage nets
 Storage - under footrest
 Windshield - Plexiglas windshield w/ handrail

Optional Features

Bow lifting ring
 Bow pulpit (includes high profile bow rail)
 Cockpit bolsters
 Cockpit shower w/10-gallon freshwater tank
 Head - portable

Canvas Options

Bimini top w/boot
 Console cover
 T-top front & side curtains



Console with lockable electronics box

22' CENTER CONSOLE

Fisherman 222

"Grady-White has a great reputation so I expected a lot. I got it." —Bill Cloys, *Fisherman* owner

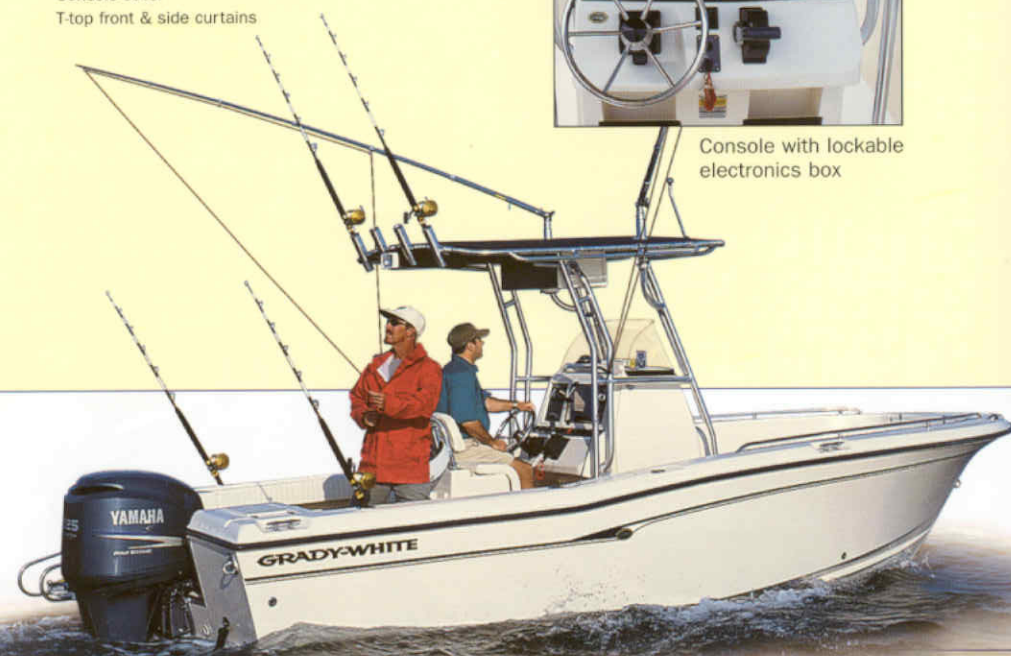

Fuel capacity - 96-gallon tank
 Heavy-duty gunwale molding
 Hydraulic trim tabs
 International lighting
 Rod holders (4)
 Rod storage racks - 6 horizontal
 Seating - 2 pedestal chairs
 Spring line cleats
 Stern eyes
 Storage - forward anchor locker w/rope storage
 Storage - aft deck lift out boxes (2)
 Washdown - pressurized raw water w/hose

Head - portable w/deck pump out
 Head - portable w/in-line macerator
 Livewell (lean bar option only) - 23-gallon insulated raw water livewell w/cushion
 Outrigger kit - 15-ft. Radial Top Gun T-top mounted
 Seating - deluxe lean bar w/footrest, backrest, tackle trays, lockable storage & 4 rod holders
 Seating - forward platform cushions
 Seating - 2 folding aft jump seats w/cushions
 Swim platform w/ladder
 T-top w/rod holders, radio box, dome light, storage net & spreader light



Casting platform with insulated fish boxes



Aft cockpit fold down motorwell bulkhead and optional bolsters

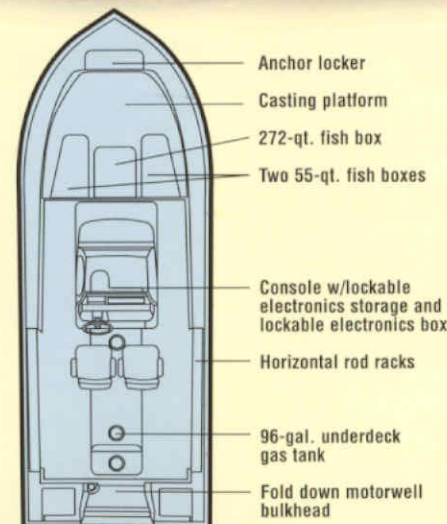

Lockable head area with storage and optional portable head



GRADY-WHITE

YAMAHA

Beam Amidships: 8'
Bridge Clearance: 5'5"
Center Line Length: 22'2"
Cockpit Depth: 26"

Cockpit Square Footage: 49 sq. ft.
Hull Draft: 15"
Maximum HP: 250
Outboard Shaft Length: 25"

Standard Fuel Capacity: 92 gal.
Transom Width: 7'11"
Weight w/o Engine: 2875 lb.

Standard Features

Safety

Automatic bilge pump (1700 GPH)
 Basic flotation
 Bow rail - low profile 316 grade stainless steel
 Chrome-over-bronze through-hull fittings
 Cockpit toe rails
 Companion grab rail
 Fold down motor well bulkhead
 Nonskid fiberglass liner
 Self-bailing cockpit w/4 cockpit drains

Cockpit & Deck

100% hand laid hull and deck
 Accessory outlet (12V)
 Cockpit lights
 Deck hardware - 316 grade stainless steel through-bolted

Drink holders (6)
 Fish box - 190-qt. starboard insulated fish box w/ob drain
 Fish box - divided port insulated fish box (90-qt. & 45-qt. sections w/ob drains)
 Footrests (helm & companion)
 Fuel capacity - 92-gallon tank
 Heavy-duty gunwale molding
 Hydraulic trim tabs
 Ice box - 30-qt. bow seat starboard insulated ice box w/ob drain
 International lighting
 Rod holders (4)
 Rod storage racks - 6 horizontal
 Seating - deluxe helm & companion chairs
 Seating - port & starboard fish box cushions
 Seating - 2 aft seats
 Seating - bow cushions

Spring line cleats
 Steering - hydraulic tilt
 Steering wheel - 316 grade stainless steel
 Stern eyes
 Storage - forward anchor locker w/rope storage
 Storage - port bow seat compartment
 Storage - lockable electronics box
 Storage - lockable glove box
 Storage - lockable console storage compartment
 Storage - lockable console tackle drawers
 Windshield - walk-through windshield
 Windshield wiper (starboard)

Optional Features

Auxiliary fuel capacity - 56-gallon tank
 Bow lifting ring
 Cockpit bolsters
 Cockpit shower w/10-gallon freshwater tank

Livewell - 90-qt. insulated raw water livewell
 Seating - bow seat back cushions
 Seating - port sleeper seat
 Swim platform w/ladder
 Washdown - pressurized raw water w/hose

Canvas Options

Bow cover
 Drop curtain
 Vista top w/side curtains and boot

22' DUAL CONSOLE

Tournament 223

"Very fishable, and if you want to cruise, too, this is the best boat on the market."—George Morris, *Tournament 223* owner



Bow area with optional bow seat back cushions



Helm station

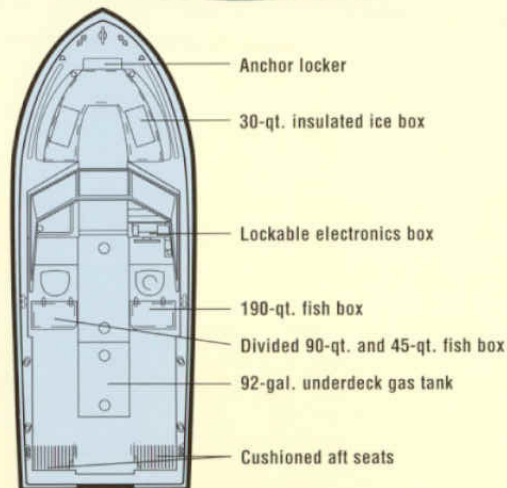

Cockpit forward



GRADY-WHITE

YAMAHA

Beam Amidships: 8'
Bridge Clearance: 6'2"
w/Hardtop: 8'4"
Center Line Length: 22'2"
Cockpit Depth: 25"

Cockpit Square Footage: 49 sq. ft.
Hull Draft: 15"
Maximum HP: 250
Outboard Shaft Length: 25"
Standard Fuel Capacity: 92 gal.

Transom Width: 7'11"
Weight w/o Engine:
226: 3225 lb. (standard transom)
228: 3350 lb. (Grady Drive transom)

Standard Features

Safety

2 automatic bilge pumps (total 2500 GPH)
 Basic flotation
 Bow rail - 316 grade stainless steel
 Chrome-over-bronze through-hull fittings
 Cockpit toe rails
 Companion grab rail
 Fold down motorwell bulkhead (226 only)
 Nonskid fiberglass liner
 Nonskid recessed walkaround
 Self-bailing cockpit w/4 cockpit drains

Cabin

Berth - forward vee berth
 Cabin light
 Forward hatch - low profile acrylic hatch w/screen

Fuel capacity - 92-gallon tank
 Heavy-duty gunwale molding
 Hydraulic trim tabs
 International lighting
 Rod holders (4)
 Rod storage holders - 4 vertical (228 only)
 Rod storage racks - 6 horizontal
 Seating - 2 pedestal chairs
 Seating - port aft facing seat
 Seating - starboard fish box cushion
 Seating - 2 aft seats
 Seating - foredeck cushions
 Spring line cleats
 Steering - hydraulic tilt
 Steering wheel - 316 grade stainless steel
 Stern eyes
 Storage - forward anchor locker w/rope storage

Washdown - pressurized raw water w/hose
 Windshield wiper (port)

Canvas Options

Drop curtain (hardtop or vista top)
 Hardtop front & side curtains
 Helm station cover
 Vista top w/side curtains & boot



Grady Drive cockpit aft with optional bolsters



Helm station



22' WALKAROUND CABIN • 226: STANDARD TRANSOM • 228: GRADY DRIVE

Seafarer 226/228

"The boat is the best value available."

—John Heck, *Seafarer* owner

Lockable door w/screen & companionway hatch
 Rod storage holders (4)
 Sink
 Storage - cabinet
 Storage - portable head compartment
 Storage - under berth compartments (3)
 Windows - opening windows w/screens (2)

Cockpit & Deck

100% hand laid hull and deck
 Accessory outlet (12V)
 Bait rigging area w/cutting board & drink holders (228 only)
 Cockpit lights
 Cockpit shower
 Deck hardware - 316 grade stainless steel through-bolted
 Drink holders (4)
 Fish box - 190-qt. starboard insulated fish box w/ob drain
 Fish box - divided port insulated fish box (80-qt. & 45-qt. sections w/ob drains)
 Fish box - 60-qt. aft fish box (228 only)
 Footrests (helm & companion)

Storage - lockable helm station radio box
 Storage nets
 Storage - tackle drawers under helm & companion chairs
 Water tank - 10-gallon freshwater
 Windshield - ventilated windshield
 Windshield wiper (starboard)

Optional Features

Auxiliary fuel capacity - 56-gallon tank
 Bow lifting ring
 Bow pulpit
 Cockpit bolsters
 Hardtop w/radio box, storage net & spreader lights
 Hardtop rod holders
 Head - portable
 Head - portable w/deck pump out
 Head - portable w/in-line macerator
 Livewell - 80-qt. insulated raw water livewell
 Seating - deluxe helm & companion chairs
 Swim platform w/ladder
 Swim platform w/ladder (full width) (228 only)

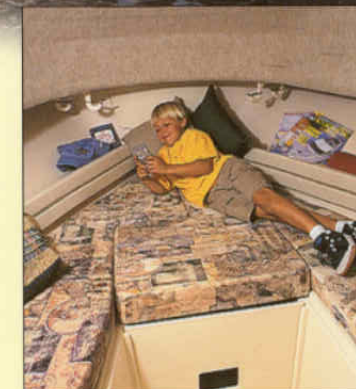
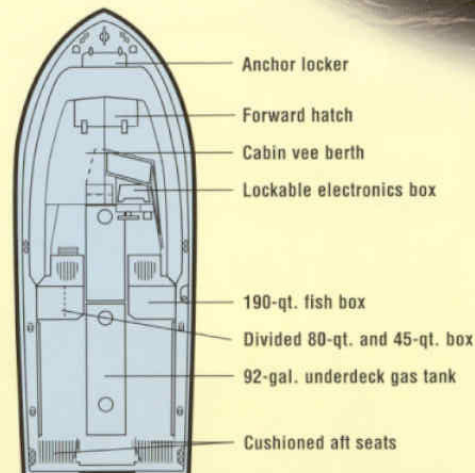

Cabin interior shown without auxiliary berth cushion



GRADY-WHITE

V150
YAMAHA
V150
V150

Beam Amidships: 9'3"
Bridge Clearance: 6'5"
w/Hardtop: 8'8"
Center Line Length: 23'5"
Cockpit Depth: 27"

Cockpit Square Footage: 56 sq. ft.
Hull Draft: 17"
Maximum HP: 400
Outboard Shaft Length:
Single: 25" Dual: 25"

Standard Fuel Capacity: 148 gal.
Transom Width: 8'10"
Weight w/o Engine:
232S: 4025 lb.
232D: 4092 lb.

Standard Features

Safety

2 automatic bilge pumps (total 2950 GPH)
 Basic flotation
 Bow rail - 316 grade stainless steel
 Chrome-over-bronze through-hull fittings
 Cockpit toe rails
 Companion grab rail
 Nonskid fiberglass liner
 Nonskid recessed walkaround
 Self-bailing cockpit w/4 cockpit drains

Cabin

Berths - 2 berths (upper & lower)
 Cabin lights
 Forward hatch - low profile acrylic hatch w/screen

Fuel capacity - 148-gallons (92-gallon tank, 56-gallon tank)
 Heavy duty gunwale molding
 Hydraulic trim tabs
 Ice box - two 38-qt. aft insulated ice boxes w/ob drain
 Ice box - 38-qt. port insulated ice box w/ob drain
 International lighting
 Livewell - 26-gallon port insulated raw water livewell w/ob drain
 Rod holders (4)
 Rod storage racks - 6 horizontal
 Seating - foredeck cushions
 Seating - deluxe helm & companion chairs
 Seating - port aft facing seat
 Seating - starboard fish box cushion
 Seating - molded in aft bench seat w/cushion
 Spring line cleats

Head - portable w/in-line macerator
 Outrigger kit - 18-ft. Lee Jr. cabin side mounted (w/hardtop option only)
 Rod storage - folding cabin rack (6)
 Stereo/CD system
 Swim platform w/ladder
 Swim platform w/ladder (full width)
 Windshield washer - freshwater (starboard)

Canvas Options

Hardtop drop curtain
 Hardtop front & side curtains
 Helm station cover



Helm station



Aft cockpit with optional bolsters

23' WALKAROUND CABIN

Gulfstream 232

"This is a wonderful boat, just right for the rough waters off of Massachusetts." —Richard & Susan Stella, *Gulfstream* owners



Galley - portside galley w/sink
 Ice box - insulated ice box w/ob drain
 Lockable door w/screen & companionway hatch
 Rod storage holders (2)
 Storage - forward compartment
 Storage nets
 Storage - port compartment
 Storage - portable head compartment
 Storage - under berth compartment
 Storage - under sink compartment
 Storage - under step compartment
 Windows - opening windows w/screens (2)

Cockpit & Deck

100% hand laid hull and deck
 Accessory outlet (12V)
 Cockpit lights
 Cockpit shower
 Deck hardware - 316 grade stainless steel through-bolted
 Drink holders (4)
 Fish box - 265-qt. starboard insulated fish box w/ob drain
 Footrests - adjustable (helm & companion)

Steering - hydraulic tilt
 Steering wheel - 316 grade stainless steel
 Stern eyes
 Storage - forward anchor locker w/rope storage
 Storage - lockable electronics box
 Storage - tackle trays under helm chair (2)
 Storage - tackle drawers under companion seat (2)
 Washdown - pressurized raw water w/hose
 Water tank - 10-gallon freshwater
 Windshield - ventilated windshield
 Windshield wipers

Optional Features

Bow lifting ring
 Bow pulpit
 Cockpit bolsters
 Cushions - auxiliary berth cushions
 Fuel option (duals only) - 182-gallon total capacity (90-gallon tank & 92-gallon tank)
 Hardtop w/radio box, storage net & spreader lights
 Hardtop rod holders
 Head - portable
 Head - portable w/deck pump out

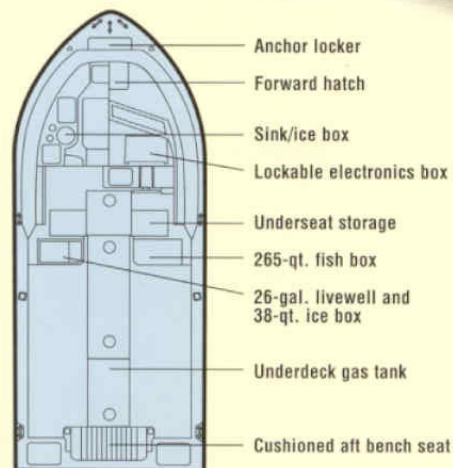

Cabin interior



Beam Amidships: 8'6"
Bridge Clearance: 7'
w/T-top: 8'5"
Center Line Length: 24'9"
Cockpit Depth: 27"

Cockpit Square Footage: 62 sq. ft.
Hull Draft: 15"
Maximum HP: 350
Outboard Shaft Length:
Single: 30" Dual: 25"

Standard Fuel Capacity: 151 gal.
Transom Width: 7'10"
Weight w/o Engine: 3500 lb.

Standard Features

Safety

Automatic bilge pump (1700 GPH)
 Basic flotation
 Bow rail - low profile 316 grade stainless steel
 Chrome-over-bronze through-hull fittings
 Cockpit toe rails
 Console grab rail
 Nonskid fiberglass liner
 Self-bailing cockpit w/4 cockpit drains

Cockpit & Deck

100% hand laid hull and deck
 Casting platform (raised)
 Cockpit lights

Spring line cleats
 Stern eyes
 Storage - forward anchor locker w/rope storage
 Storage - forward tackle trays
 Transducer mounting flats
 Transom door
 Washdown - pressurized raw water w/hose
 Water tank - 20-gallon freshwater

Console

Accessory outlet (12V)
 Console ventilator
 Drink holders (2)
 Head - lockable console w/stand up head area,
 storage shelves & hanging locker

T-top w/rod holders, radio box, dome light,
 storage net & spreader light

Canvas Options

T-top front & side curtains



Center console with lockable electronics box



Insulated bow fish boxes

24' CENTER CONSOLE

Advance 247

"Laid out to be the perfect boat in this size class."

—Neal Bowersox, *Advance* owner



Cockpit shower
 Cutting board
 Deck hardware - 316 grade stainless steel through-bolted
 Fish box - 120-qt. divided port insulated fish box w/ob drain
 Fish box - 120-qt. starboard insulated fish box w/ob drain
 Fuel capacity - 151-gallon tank
 Heavy-duty gunwale molding
 Hydraulic trim tabs
 Integrated outboard mounting system w/swim platform & ladder
 International lighting
 Livewell - 37-gallon aft insulated raw water livewell w/light, full column distribution inlet & ob drain
 Rod holders (4)
 Rod storage racks - 6 horizontal
 Seating - deluxe lean bar w/footrest, backrest, tackle trays, lockable storage & 4 rod holders

Seating - molded forward console seat w/cushion
 Steering - hydraulic tilt
 Steering wheel - 316 grade stainless steel
 Storage - lockable electronics box
 Storage nets
 Storage - under footrest
 Windshield - Plexiglas windshield w/handrail

Optional Features

Bow lifting ring
 Bow pulpit (includes high profile bow rail)
 Cockpit bolsters
 Electronics flush mount kit
 Head - portable
 Head - portable w/deck pump out
 Head - portable w/in-line macerator
 Outrigger kit - 15-ft. Radial Top Gun T-top mounted
 Seating - forward platform cushions
 Stereo/CD system

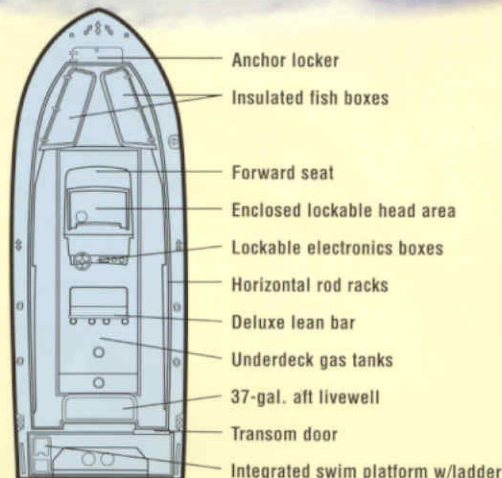

Aft cockpit with livewell and optional bolsters



Beam Amidships: 8'6"
Bridge Clearance: 6'6"
 w/Hardtop: 8'8"
Center Line Length: 24'9"
Cockpit Depth: 27"

Cockpit Square Footage: 55 sq. ft.
Hull Draft: 15"
Maximum HP: 350
Outboard Shaft Length:
 Single: 30" Dual: 25"

Standard Fuel Capacity: 105 gal.
Transom Width: 7'10"
Weight w/o Engine: 4043 lb.



Cockpit forward with optional cockpit bolsters

Standard Features

Safety

2 automatic bilge pumps (total 2950 GPH)
 Basic flotation
 Bow rail - 316 grade stainless steel
 Chrome-over-bronze through-hull fittings
 Cockpit toe rails
 Companion grab rail
 Nonskid fiberglass liner
 Nonskid recessed walkaround
 Self-bailing cockpit w/4 cockpit drains

Cabin

Berth - forward vee berth
 Cabin light
 Carpet

Hydraulic trim tabs
 Ice box - 46-qt. port insulated ice box w/ob drain
 Integrated outboard mounting system
 w/swim platform and ladder
 International lighting
 Rod holders (4)
 Rod storage racks - 6 horizontal
 Seating - deluxe helm & companion chairs
 Seating - port & starboard fish box cushions
 Seating - molded in aft bench seat w/cushion
 Seating - foredeck cushions
 Spring line cleats
 Steering - hydraulic tilt
 Steering wheel - 316 grade stainless steel
 Stern eyes
 Storage - forward anchor locker w/rope storage

Rod storage - folding cabin rack (6)
 Stereo/CD system
 Washdown - pressurized raw water w/hose
 Windshield washer - freshwater (starboard)
 Windshield wiper (port)

Canvas Options

Drop curtain (hardtop or vista top)
 Hardtop front & side curtains
 Helm station cover
 Vista top w/side curtains & boot



Helm station

24' WALKAROUND CABIN

Voyager 248

"Everyone recognizes this boat as quality. It's like owning a Rolls Royce."—Ed Wilgus, *Voyager* owner



Forward hatch - low profile acrylic hatch w/screen
 Lockable door w/screen & companionway hatch
 Rod storage holders (4)
 Sink
 Storage nets
 Storage - portable head compartment
 Storage - under berth compartments (5)
 Windows - opening windows w/screens (2)

Cockpit & Deck

100% hand laid hull and deck
 Accessory outlet (12V)
 Cockpit lights
 Cockpit shower
 Deck hardware - 316 grade stainless steel
 through-bolted
 Drink holders (3)
 Fish box - 154-qt. starboard insulated fish box
 w/ob drain
 Fish box - 102-qt. port insulated fish box w/ob drain
 Footrest - adjustable (helm & companion)
 Fuel capacity - 105-gallon tank
 Heavy-duty gunwale molding

Storage - lockable electronics box
 Storage - lockable storage under helm seat
 Storage - tackle drawer under companion seat
 Storage - aft deck lift out box
 Transducer mounting flats
 Water tank - 10-gallon freshwater
 Windshield - ventilated windshield
 Windshield wiper (starboard)

Optional Features

Auxiliary fuel capacity - 56-gallon tank
 Bow lifting ring
 Bow pulpit
 Cockpit bolsters
 Hardtop w/radio box, storage net & spreader lights
 Hardtop rod holders
 Head - marine head w/macerator,
 10-gallon holding tank & pump out
 Head - portable
 Head - portable w/deck pump out
 Head - portable w/in-line macerator
 Livewell - 102-qt. insulated raw water livewell

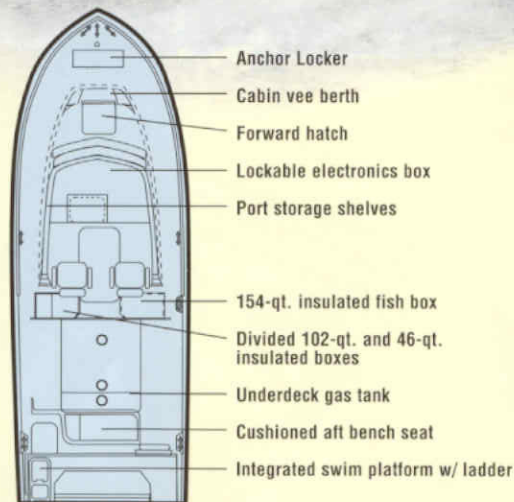

Cabin interior with optional rod rack



Beam Amidships: 9'7"
Bridge Clearance: 7'
w/Hardtop: 10'1"
Center Line Length: 25'9"

Cockpit Depth: 26"
Cockpit Square Footage: 58 sq. ft.
Hull Draft: 15"
Maximum HP: 500

Outboard Shaft Length: 25"
Standard Fuel Capacity: 250 gal.
Transom Width: 8'8"
Weight w/o Engines: 5390 lb.

Standard Features

Safety

2 automatic bilge pumps (total 2950 GPH)
 Basic flotation
 Bow rail - 316 grade stainless steel
 Chrome-over-bronze through-hull fittings
 Cockpit toe rails
 Companion grab rail
 Nonskid fiberglass liner
 Self-balling cockpit w/4 cockpit drains

Cabin

Berth - forward vee berth
 Cabin lights
 Carpet
 Forward hatch - low profile acrylic hatch w/screen

Fold down motorwell bulkhead
 Footrest (helm)
 Fuel capacity - 250 gallons
 (130-gallon tank, 120-gallon tank)
 Heavy-duty gunwale molding
 Hydraulic trim tabs
 International lighting
 Livewell - 40-gallon insulated raw water livewell w/light,
 full column distribution inlet & ob drain
 Rigging station w/freshwater sink, insulated bait box
 w/ob drain & lockable drawers
 Rod holders (4)
 Rod storage racks - 6 horizontal
 Seating - adjustable deluxe center helm chair
 Seating - foredeck cushions
 Seating - helm area surround seats

Hardtop w/radio box, storage net & spreader lights
 Hardtop rod holders
 Head - marine head w/electric flush (10-gallon)
 Outrigger kit - 18-ft. Lee Jr. cabin side mounted
 (w/hardtop option only)
 Stereo/CD system
 Swim platform w/ladder

Canvas Options

Hardtop drop curtain
 Hardtop front & side curtains
 Helm station cover

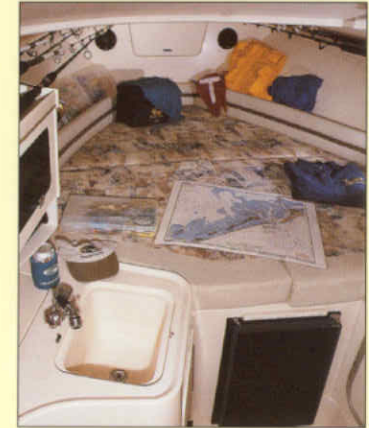

Cabin interior

26' EXPRESS CABIN

Express 265

"The finish, the quality, the ride; I am just crazy about my 265. There's nothing better in this size on the market."—Ben Lawrence, *Express 265* owner



Galley - port side galley w/sink
 Head - enclosed head area w/sink, shower and lamp
 Head - marine head w/macerator,
 10-gallon holding tank & pump out
 Lockable door w/screen & companionway hatch
 Mirror
 Refrigerator
 Rod storage holders (6)
 Storage - galley area
 Storage net
 Storage - under berth compartments (3)
 Stove - butane
 Water tank - 20-gallon freshwater

Cockpit & Deck

100% hand laid hull and deck
 Accessory outlet (12V)
 Bow pulpit
 Cockpit bolsters
 Cockpit lights
 Deck hardware - 316 grade stainless steel through-bolted
 Drink holders (6)
 Fish box - 300-qt. insulated center fish box w/ob drain

Seating - port livewell cushion
 Seating - starboard tackle station cushion
 Spring line cleats - flush mount
 Steering - hydraulic tilt
 Steering wheel - 316 grade stainless steel
 Stern eyes
 Storage - aft deck lift out boxes (2)
 Storage - dry storage below starboard surround seat
 Storage - tackle drawer below port bench seat
 Storage - forward anchor locker w/rope storage
 Storage - lockable electronics box
 Washdown - pressurized raw water w/hose
 Windshield - ventilated windshield
 Windshield washer - freshwater
 Windshield wiper

Optional Features

Anchor windlass
 Bow lifting ring
 Convenience package -
 Battery charger, dockside power
 w/galvanic isolator, microwave oven &
 water heater (6-gallon, 110V)

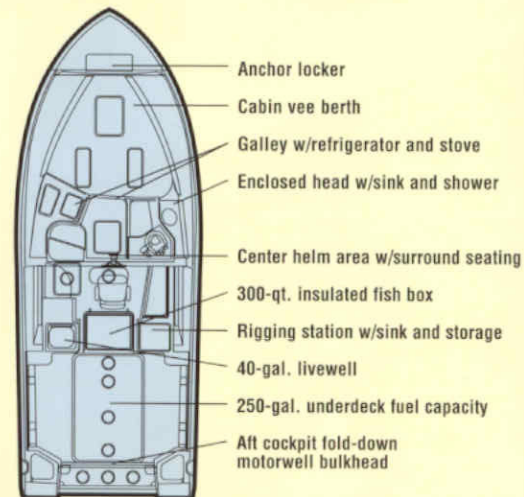

Cockpit forward with helm and surround seating



Aft cockpit with fold-down motorwell bulkhead



GRADY-WHITE

YAMAHA 200

Beam Amidships: 8'6"
Bridge Clearance: 7'
w/Hardtop: 9'3"
Center Line Length: 26'11"
Cockpit Depth: 28"

Cockpit Square Footage: 57 sq. ft.
Hull Draft: 15"
Maximum HP: 500
Outboard Shaft Length:
Single: 30" Dual: 25"

Standard Fuel Capacity: 150 gal.
Transom Width: 7'10"
Weight w/o Engine: 4660 lb.

Standard Features

Safety

2 automatic bilge pumps (total 2950 GPH)
 Basic flotation
 Bow rail - 316 grade stainless steel
 Chrome-over-bronze through-hull fittings
 Cockpit toe rails
 Companion grab rail
 Nonskid fiberglass liner
 Nonskid recessed walkaround
 Self-bailing cockpit w/4 cockpit drains

Cabin

Berth - forward vee berth
 Cabin lights
 Cabin window curtains
 Carpet

Drink holders (6)
 Fish box - 186-qt. starboard insulated fish box w/ob drain
 Fish box - 104-qt. port insulated fish box w/ob drain
 Footrest - adjustable (helm)
 Fuel capacity - 150-gallon tank
 Heavy-duty gunwale molding
 Hydraulic trim tabs
 Ice box - 38-qt. port insulated ice box w/ob drain
 Integrated outboard mounting system
 w/swim platform and ladder
 International lighting
 Rod holders (4)
 Rod storage racks - 6 horizontal
 Seating - deluxe helm chair (starboard)
 Seating - companion bench seat
 Seating - port & starboard fish box cushions
 Seating - molded in aft bench seat w/cushion

Convenience package #2
 Livewell - 26-gallon raw water livewell & pressurized raw water washdown w/hose
 Hardtop w/radio box, storage net & spreader lights
 Hardtop rod holders
 Head - marine head w/electric flush (10-gallon)
 Outrigger kit - 18-ft. Lee Jr. cabin side mounted (w/hardtop option only)
 Rod storage - folding cabin rack (6)
 Stereo/CD system
 Windshield washer - freshwater (starboard)

Canvas Options

Drop curtain (hardtop or vista top)
 Hardtop front & side curtains
 Helm station cover
 Vista top w/side curtains & boot



Cabin interior with optional microwave



27' WALKAROUND CABIN

Islander 270

"Ever had a toy as a kid that all the kids wanted?
 That sums it up for me." —Jeff Brooks, *Islander* owner

Forward hatch w/screen
 Galley - port side galley w/sink
 Head - enclosed head area w/sink, shower & lamp
 Head - marine head w/macerator,
 10-gallon holding tank & pump out
 Lockable door w/screen & companionway hatch
 Mirror
 Refrigerator
 Rod storage holders (2)
 Storage - galley area
 Storage nets
 Storage - under berth compartments (3)
 Stove - butane
 Table
 Water tank - 32-gallon freshwater
 Windows - front windows (2)
 Windows - sliding side windows w/screens (2)

Cockpit & Deck

100% hand laid hull and deck
 Accessory outlet (12V)
 Bow pulpit
 Cockpit lights
 Cockpit shower
 Deck hardware - 316 grade stainless steel through-bolted

Seating - foredeck cushions
 Spring line cleats
 Steering - hydraulic tilt
 Steering wheel - 316 grade stainless steel
 Stern eyes
 Storage - forward anchor locker w/rope storage
 Storage - lockable electronics box
 Storage - lockable storage behind companion seat
 Storage - tackle drawers under helm seat (2)
 Storage - aft deck lift out box
 Transom door
 Windshield - ventilated windshield
 Windshield wipers

Optional Features

Anchor windlass
 Auxiliary fuel capacity - 56 gallons (duals only)
 Bow lifting ring
 Cockpit bolsters
 Convenience package #1
 Battery charger, dockside power
 w/galvanic isolator, microwave oven,
 water heater (6-gallon, 110V)

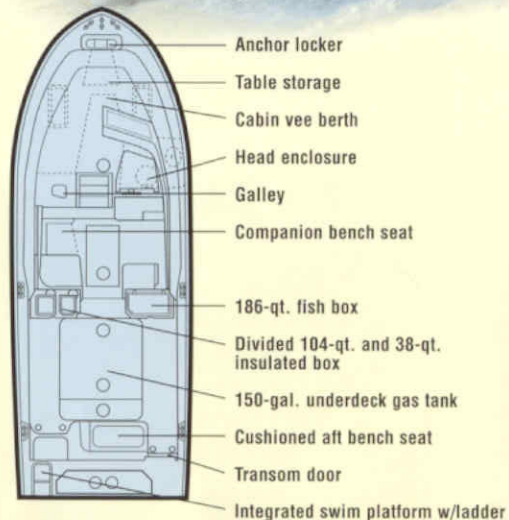

Cockpit forward



Head enclosure with extending shower faucet



GRADY-WHITE

YAMAHA

Beam Amidships: 8'6"
Bridge Clearance: 6'9"
 w/T-top 8'3"
Center Line Length: 26'11"
Cockpit Depth: 27"

Cockpit Square Footage: 65 sq. ft.
Hull Draft: 15"
Maximum HP: 500
Outboard Shaft Length:
 Single 30" Dual 25"

Standard Fuel Capacity: 205 gal.
Transom Width: 7'10"
Weight w/o Engine: 3975 lb.

Standard Features

Safety

2 automatic bilge pumps (2950 GPH)
 Basic flotation
 Bow rail - low profile 316 grade stainless steel
 Chrome-over-bronze through-hull fittings
 Cockpit toe rails
 Console grab rails
 Nonskid fiberglass liner
 Self-bailing cockpit w/4 cockpit drains

Cockpit & Deck

100% hand laid hull and deck
 Battery select switch
 Cockpit lights
 Cockpit shower

Spring line cleats
 Stern eyes
 Storage - forward anchor locker w/rope storage
 Transom door
 Washdown - pressurized raw water w/hose
 Water tank - 20-gallon freshwater

Console

Accessory outlet (12V)
 Console ventilator
 Drink holders (2)
 Head - lockable console w/stand up head area, sink, bulk storage & drawers
 Seating - molded forward console seat w/cushion
 Steering - hydraulic tilt
 Steering wheel - 316 grade stainless steel

Outrigger kit - 15-ft. Radial Top Gun T-top mounted
 Stereo/CD system
 T-top w/rod holders, radio box, dome light, storage net & spreader light

Canvas Options

T-top front & side curtains



Bow fish boxes convert to bow seats; optional casting platform bolsters. (See boat below for optional casting platform.)



Lockable rod storage

27' CENTER CONSOLE

Chase 273

"The quality, styling, accommodations, hull design, engineering and price are all outstanding." —Michael Bass, Chase owner



Cutting board
 Deck hardware - 316 grade stainless steel through-bolted
 Drink holder (1)
 Fish box - 104-qt. divided port insulated fish box w/ob drain
 Fish box - 104-qt. starboard insulated fish box w/ob drain
 Fish box - 185-qt. aft deck insulated fish box
 Fuel capacity - 205-gallon tank
 Heavy-duty gunwale molding
 Hydraulic trim tabs
 Integrated outboard mounting system w/swim platform & ladder
 International lighting
 Livewell - 32-gallon aft deck insulated raw water livewell w/light, full column distribution inlet & ob drain
 Rod holders (4)
 Rod storage - lockable horizontal storage for 6 rods
 Seating - deluxe lean bar w/footrest, backrest, tackle trays, lockable storage, 4 rod holders & removable 94-qt. cooler
 Seating - fold away aft bench seat w/cushion

Storage - electro-mechanically operated electronics enclosure
 Windshield - Plexiglas windshield w/handrail

Optional Features

Anchor windlass
 Bow lifting ring
 Bow pulpit (includes high profile bow rail)
 Casting platform insert
 Casting platform insert cushions
 Cockpit bolsters (aft)
 Convenience package - Casting platform bolsters and forward fish box cushions
 Head - portable
 Head - portable w/deck pump out
 Head - portable w/in-line macerator
 Head - marine head w/macerator, 10-gallon holding tank & pump out
 Head - marine head w/electric flush (10-gallon)

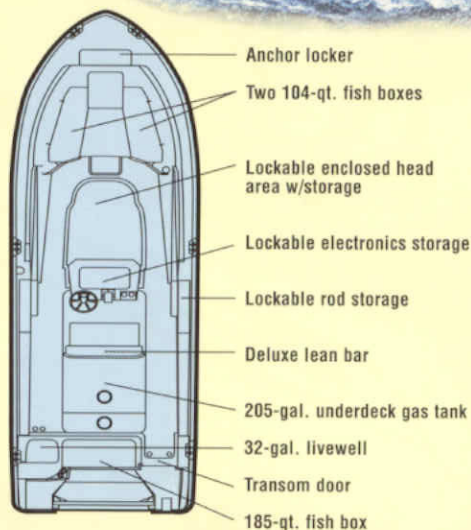

Fold away aft bench seat w/cushion, transom door; optional cockpit bolsters



Console with electro-mechanically operated electronics enclosure



Beam Amidships: 9'6"
Bridge Clearance: 7'7"
w/Hardtop: 9'9"
Center Line Length: 28'

Cockpit Depth: 28"
Cockpit Square Footage: 59 sq. ft.
Hull Draft: 18"
Maximum HP: 500

Outboard Shaft Length: 25"
Standard Fuel Capacity: 220 gal.
Transom Width: 9'
Weight w/o Engines: 5800 lb.

Standard Features

Safety

2 automatic bilge pumps (total 2950 GPH)
 Basic flotation
 Bow rail - 316 grade stainless steel
 Chrome-over-bronze through-hull fittings
 Cockpit toe rails
 Companion grab rail
 Nonskid fiberglass liner
 Nonskid recessed walkaround
 Self-bailing cockpit w/4 cockpit drains

Cabin

Berth - forward vee berth
 Berth - aft berth
 Cabin lights
 Cabin window curtains
 Carpet

Cockpit bolsters
 Cockpit lights
 Deck hardware - 316 grade stainless steel through-bolted
 Drink holders (5)
 Fish box - 325-qt. starboard insulated fish box w/ob drain
 Footrests - adjustable (helm & companion)
 Fuel capacity - 220 gallons (150-gallon tank, 70-gallon tank)
 Hardtop w/radio box, storage net & spreader lights
 Hardtop drop curtains
 Hardtop front & side curtains
 Heavy-duty gunwale molding
 Hydraulic trim tabs
 Ice box - 46-qt. aft deck insulated ice box w/ob drain
 Integrated outboard mounting system
 w/swim platform and ladder
 International lighting
 Livewell - 40-gallon insulated raw water livewell w/light,
 full column distribution inlet & ob drain

Optional Features

Air conditioning
 Anchor windlass
 Bow lifting ring
 Convenience package-
 Battery charger, dockside power
 w/galvanic isolator, microwave oven,
 water heater (6-gallon, 110V)
 Hardtop rod holders
 Head - marine head w/electric flush (10-gallon)
 Outtrigger kit - 18-ft. Lee Jr. cabin side mounted
 (w/hardtop option only)
 Rod storage - folding cabin rack (6)
 Seating - companion bench seat
 Stereo/CD system

Canvas Options

Helm station cover



Cockpit forward



325-qt. starboard insulated fish box
w/ob drain

28' WALKAROUND CABIN

Sailfish 282

"My Grady handles great offshore and is the best boat I have ever owned." —John Zydron, *Sailfish* owner



Forward hatch - low profile acrylic hatch w/screen
 Galley - port side galley w/sink
 & insulated ice box w/ob drain
 Head - enclosed head area w/sink, shower & lamp
 Head - marine head w/macerator,
 10-gallon holding tank & pump out
 Lockable door w/screen & companionway hatch
 Mirror
 Refrigerator
 Rod storage holders (4)
 Storage - galley shelves
 Storage nets
 Storage - under berth compartments (3)
 Stove - butane
 Table
 Water tank - 32-gallon freshwater
 Windows - opening windows w/screens (2)

Cockpit & Deck

100% hand-laid hull and deck
 Accessory outlet (12V)
 Anchor windlass wiring
 Bow pulpit

Rigging station - aft deck station w/sink
 & pull out freshwater faucet
 Rod holders (4)
 Rod storage racks - 6 horizontal
 Seating - adjustable deluxe helm & companion chairs
 Seating - foredeck cushions
 Seating - port & starboard fish box cushions
 Seating - molded in aft bench seat w/cushion
 Spring line cleats
 Steering - hydraulic tilt
 Steering wheel - 316 grade stainless steel
 Stern eyes
 Storage - aft bench seat lift out tackle tray
 Storage - forward anchor locker w/rope storage
 Storage - lockable electronics box
 Storage - lockable storage under companion seat
 Storage - tackle drawers under helm seat (2)
 Transducer mounting flats
 Transom door
 Washdown - pressurized raw water w/hose
 Windshield - ventilated windshield
 Windshield washer - freshwater (starboard)
 Windshield wipers

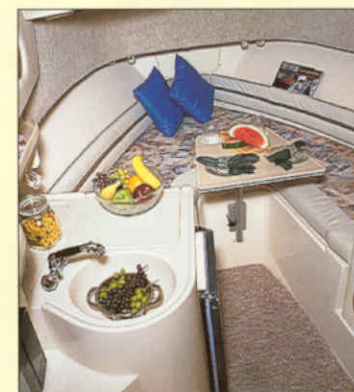
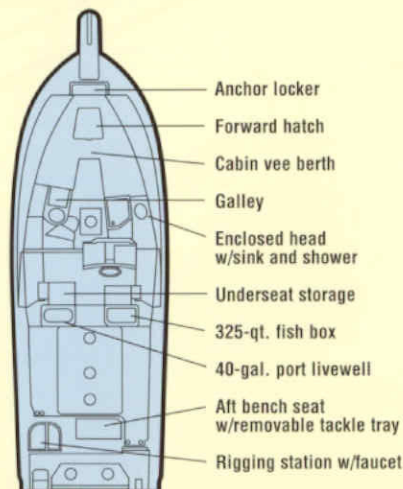

Cabin interior



GRADY-WHITE

YAMAHA

Beam Amidships: 10'7"
Bridge Clearance: 8'3"
w/Hardtop: 9'9"
Center Line Length: 30'6"
Length Overall (w/pulpit): 32'7"

Cockpit Depth: 29"
Cockpit Square Footage: 74 sq. ft.
Hull Draft: 19"
Maximum HP: 500

Outboard Shaft Length: 25"
Standard Fuel Capacity: 306 gal.
Transom Width: 9'6"
Weight w/o Engines: 7000 lb.

Standard Features

Safety

2 automatic bilge pumps (total 2950 GPH)
 Basic flotation
 Bow rail - 316 grade stainless steel
 Chrome-over-bronze through-hull fittings
 Cockpit toe rails
 Companion grab rail
 Nonskid fiberglass liner
 Nonskid recessed walkaround
 Self-bailing cockpit w/4 cockpit drains

Cabin

Berth - forward vee berth
 Berth - aft double berth
 Cabin lights
 Cabin window curtains

Cockpit & Deck

100% hand laid hull and deck
 Accessory outlet (12V)
 Anchor windlass wiring
 Battery select switch
 Batteries (4)
 Battery charger system
 Bow pulpit w/anchor davit
 Cockpit bolsters
 Cockpit lights
 Cockpit shower (recessed)
 Compass
 Deck hardware - 316 grade stainless steel through-bolted
 Dockside power w/galvanic isolator
 Drink holders (8)
 Dynaplate
 Fighting chair reinforcement

Spring line cleats
 Steering - hydraulic tilt
 Steering wheel - 316 grade stainless steel
 Stern eyes
 Storage - aft seat lift out tackle tray
 Storage - forward anchor locker w/rope storage
 Storage - lockable electronics box
 Storage - lockable storage under helm & companion seats
 Storage - under step compartment
 Transducer mounting flats
 Transom door
 Washdown - pressurized raw water w/hose
 Windshield - ventilated windshield
 Windshield washer - freshwater (starboard)
 Windshield wipers

Optional Features

Air conditioning



Cockpit forward with tackle station



Cabin interior

30' WALKAROUND CABIN

Marlin 300

"Great riding boat in rough water. I go 50 miles or more offshore."

—Robert Hershberger, *Marlin* owner



Carpet
 Cutting board - Corian®
 Forward hatch - low profile acrylic hatch w/screen
 Galley - port side galley w/sink
 Head - enclosed head area w/sink, shower & lamp
 Head - marine head w/electric flush (10-gallon)
 Lockable door w/screen & companionway hatch
 Microwave oven
 Mirror
 Refrigerator
 Rod storage racks (10)
 Rod storage - aft berth
 Stereo/CD system
 Storage - galley cabinets
 Storage nets
 Storage - under berth compartments
 Stove - electric glass top
 Table - Corian®
 Water heater (6-gallon, 120V)
 Water tank - 39-gallon freshwater
 Window - aft berth window w/screen
 Windows - opening windows w/screens (2)

Fish box - 275-qt. port insulated fish box w/ob drain
 Footrests - adjustable (helm & companion)
 Fuel capacity - 306 gallons (150-gallon tank, 156-gallon tank)
 Hardtop w/radio box, storage net & spreader lights
 Hardtop drop curtain
 Hardtop front & side curtains
 Heavy-duty gunwale molding
 Hydraulic trim tabs
 Integrated outboard mounting system
 w/swim platform and ladder
 International lighting
 Livewell - 20-gallon aft deck insulated raw water
 livewell w/ob drain
 Rigging station behind helm chair w/freshwater sink,
 insulated bait box w/ob drain & lockable drawers
 Rod holders (4)
 Rod storage racks - 6 horizontal
 Seating - adjustable deluxe helm & companion chairs
 Seating - foredeck cushions
 Seating - molded in aft bench seat w/cushion
 Seating - port fish box cushion
 Seating - starboard tackle station cushion

Anchor windlass
 Generator
 Hardtop rod holders
 Outrigger kit - 19-ft. Lee Jr. cabin side mounted
 Outrigger kit - 24-ft. Lee Pro Series (fold down)
 Rod storage - folding cabin rack (6)
 Seating - companion bench seat

Canvas Options

Helm station cover



Aft bench seat, transom door
 and livewell

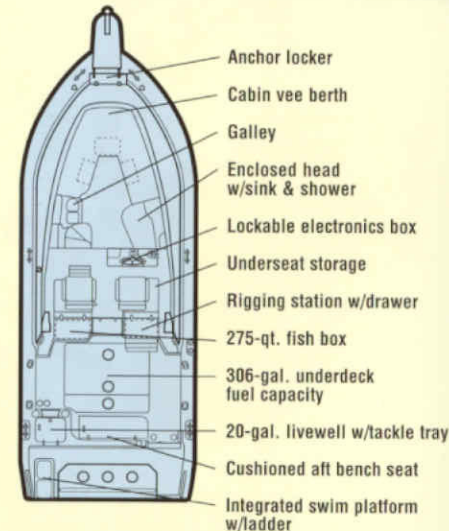



GRADY-WHITE

YAMAHA
Schimdt Series

Beam Amidships: 10'7"
Bridge Clearance: 7'3" w/T-Top: 8'9"
Center Line Length: 30'6"
Length Overall (w/pulpit): 32'7"

Cockpit Depth: 27"
Cockpit Square Footage: 75 sq. ft.
Hull Draft: 19"
Maximum HP: 500

Outboard Shaft Length: 25"
Standard Fuel Capacity: 306 gal.
Transom Width: 9'6"
Weight w/o Engines: 6500 lb.



Console with electro-mechanically operated electronics enclosure

Standard Features

Safety

2 automatic bilge pumps (total 2950 GPH)
 Basic flotation
 Bow rail - low profile 316 grade stainless steel
 Chrome-over-bronze through-hull fittings
 Cockpit toe rails
 Nonskid fiberglass liner
 Self-bailing cockpit w/4 cockpit drains

Cockpit & Deck

100% hand laid hull and deck
 Battery select switch
 Casting platform (raised)
 Cockpit bolsters (aft)
 Cockpit lights
 Cockpit shower (recessed)

Storage - forward anchor locker w/rope storage
 Storage nets
 Transducer mounting flats
 Transom door
 Washdown - pressurized raw water w/hose
 Water tank - 32-gallon freshwater

Console

Accessory outlet (12V)
 Compass
 Console ventilator
 Drink holders (4)
 Head - lockable console w/stand up head area, shower, sink, storage compartments, bulk storage & hanging locker
 Head - marine head w/macerator, 10-gallon holding tank & pump out

Head - marine head w/electric flush (10-gallon)
 Outrigger kit - 15-ft. Radial Top Gun T-Top mounted
 Stereo/CD system
 T-top w/radio box, dome light, storage net & spreader lights

Canvas Options

T-top front & side curtains



Optional T-top with storage

30' CENTER CONSOLE

Bimini 306

"Solid, stable, literally the best. It handles waves tremendously." —Robert Van Bergen, *Bimini* owner



Deck hardware - 316 grade stainless steel through-bolted
 Drink holders (2)
 Fish box - two 64-qt. port & starboard insulated fish boxes w/ob drain
 Fish box - 352-qt. center insulated fish box w/ob drain
 Fuel capacity - 306 gallons (150-gallon tank, 156-gallon tank)
 Heavy-duty gunwale molding
 Hydraulic trim tabs
 Integrated outboard mounting system w/swim platform & ladder
 International lighting
 Livewell - 41-gallon aft deck insulated raw water livewell w/light, full column distribution inlet & ob drain
 Rod holders (4)
 Rod storage - lockable horizontal storage for 6 rods
 Seating - deluxe lean bar w/footrest, backrest, tackle trays, lockable storage & 6 rod holders
 Spring line cleats
 Stern eyes

Rigging station - lean bar station w/two 21-qt. insulated bait boxes & freshwater sink
 Seating - molded forward console seat w/cushion
 Steering - hydraulic tilt
 Steering wheel - 316 grade stainless steel
 Storage - electro-mechanically operated electronics enclosure
 Storage - lockable acrylic console door
 Storage - under footrest
 Windshield - Plexiglas windshield w/handrail

Optional Features

Anchor windlass
 Bow pulpit (includes high profile bow rail)
 Convenience package #1
 Battery charger, dockside power w/galvanic isolator
 Convenience package #2
 Casting platform cushions, casting platform bolsters & fold away aft bench seat w/cushion

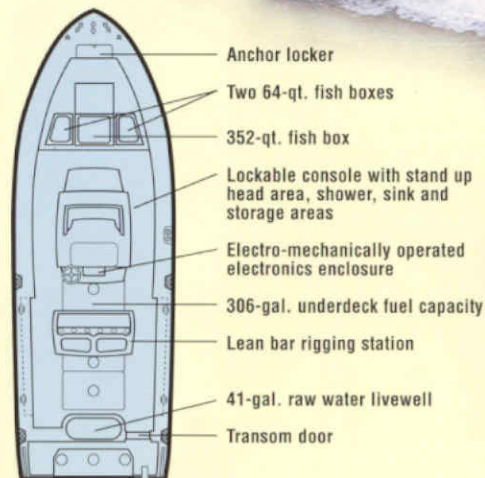

41-gallon raw water aft deck livewell



Beam Amidships: 11'7"
Bridge Clearance
 w/Hardtop: 9'10"
Center Line Length (w/o pulpit): 33'6"
Length overall (w/pulpit): 35'10"

Cockpit Depth: 29"
Cockpit Square Footage: 80 sq. ft.
Hull Draft: 21"
Maximum HP: 500
Outboard Shaft Length: 25"

Standard Fuel Capacity: 350 gal.
Transom Width: 10'6"
Weight w/o Engines: 9500
 (includes all standard features)



Helm station w/electro-mechanically operated electronics enclosure

Standard Features

Safety

2 automatic bilge pumps (total 2950 GPH)
 Basic flotation
 Bow rail - 316 grade stainless steel
 Chrome-over-bronze through-hull fittings
 Cockpit toe rails
 Companion grab rail
 Nonskid fiberglass liner
 Self-bailing cockpit w/4 cockpit drains

Cabin

Accessory outlet (12V)
 Air conditioning
 Berth - forward vee berth
 Berth - aft double berth
 Cabin lights

Cockpit & Deck

100% hand-laid hull and deck
 Accessory outlet (12V)
 Anchor windlass
 Battery select switch
 Batteries (4)
 Battery charger system
 Bow pulpit w/roller
 Cockpit bolsters
 Cockpit lights
 Cockpit shower (recessed)
 Compass
 Deck hardware - 316 grade stainless steel through-bolted
 Dockside power w/galvanic isolator
 Drink holders (7)
 Dynaplate
 Fighting chair reinforcement

Stern eyes
 Storage - aft deck lift out box
 Storage - electro-mechanically operated electronics enclosure
 Storage - forward storage for anchor rope
 Storage nets
 Storage - under helm area surround seating
 Transom door
 Washdown - pressurized raw water w/hose
 Windshield - ventilated windshield
 Windshield washer - freshwater
 Windshield wiper

Optional Features

Outrigger kit - 19-ft. Lee Jr. cabin side mounted
 Outrigger kit - 24-ft. Lee Pro Series (fold down)



Helm area surround seating

33' EXPRESS CABIN

Express 330

"This is a fabulous boat, and our fourth new Grady."
 —Laurene and Patrick Cullinan, Express 330 owners



Forward hatch curtains
 Forward hatch - two low profile acrylic hatches w/screen
 Galley - port side galley w/sink
 Head - enclosed ventilated head area
 w/sink, shower & lamps
 Head - VacuFlush marine head (10-gallon)
 Head - storage cabinet
 Lockable door w/screen & companionway hatch
 Microwave oven
 Mirrors
 Refrigerator
 Rod storage racks
 Stereo/CD system
 Storage - galley cabinets
 Storage nets
 Storage - under berth compartments
 Stove - smooth top electric
 TV/VCR combination (13")
 Teak table
 Teak & holly floor
 Water heater (6-gallon, 120V)
 Water tank - 50-gallon freshwater

Fish box - 270-qt. aft deck insulated fish box w/ob drain
 Footrest
 Fuel capacity - 350 gallons (150-gallon tank, 200-gallon tank)
 Generator
 Hardtop w/radio box, storage net, spreader lights,
 rod holders & canvas
 Heavy-duty gunwale molding
 Hydraulic trim tabs
 Integrated outboard mounting system
 w/swim platform & ladder
 International lighting
 Livewell - 45-gallon starboard insulated raw water livewell
 w/light, full column distribution inlet & ob drain
 Rod holders - 4 gunwale
 Rod storage racks - 4 horizontal
 Seating - adjustable deluxe helm chairs
 Seating - helm area surround seat w/backrests
 Seating - fold away aft bench seat w/cushion
 Sink w/fresh water
 Spring line cleats
 Steering - hydraulic tilt
 Steering wheel - 316 grade stainless steel

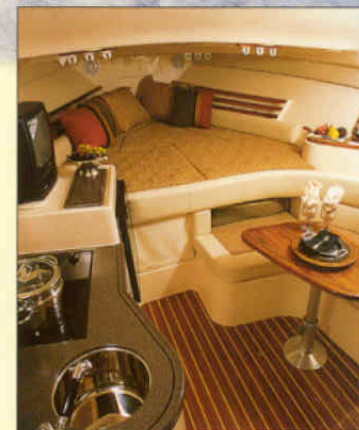
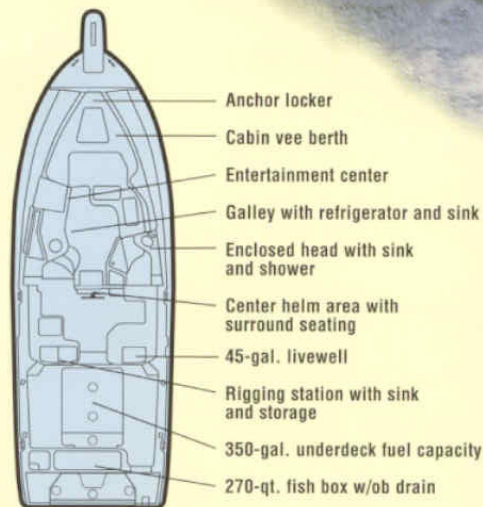

Teak and holly floor



The Express 330 was created as the new flagship of the Grady-White fleet, and with exceptional input from customers.

“Helm visibility is good.

You’re well situated in the middle and can see all angles of the boat—it’s a better design. Docking is easier. The cockpit is set up well and is great for fishing. The bolsters, plenty of storage aft, everything—the whole design is good. The overhead netting is a great idea. It gets things out of the way that you’d otherwise throw into the cabin.



Port helm seating area features a folding seat and insulated ice box



Starboard helm seating features a folding seat



Cabin interior forward featuring Corian® countertops in galley

▼ Detail of cabin flooring

“The **Express 330** cabin is good space-wise; compartments and bedding are very nice. I love the cabin flooring.”

—Laurene Cullinan, *Express 330* owner

Everything is easy to get to. My grown kids had said, ‘Oh, we won’t be able to walk around.’ Even though it’s an express model, there’s still easy access. Cabin lighting is very nice. The color scheme is eye catching. This is a fabulous boat.”

—Laurene and Patrick Cullinan, *Express 330* owners



Hardtop w/net storage, electronics enclosure and rod holders



Head enclosure with Corian® countertops and extensible shower faucet



Port side tackle station and sink



270-qt. aft deck insulated fish box; fold away aft bench seat w/cushion



Cabin interior aft featuring entertainment center and berth





▲ Hardtop front and side curtains for models 20' and up (drop curtain is available)



▲ Hardtop with lockable radio boxes, spreader lights and overhead storage net (for models 22' and up)

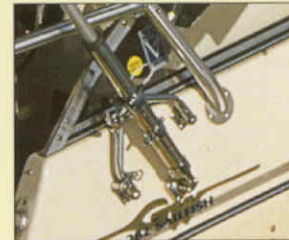

▲ Outrigger kit, cabin side mounted



▲ Bow lifting ring



▲ 208 Hardtop with lockable radio box, spreader lights and rod holders



▲ Bow seat back cushions



▲ Sleeper seat (192 shown)

Factory options for more of the best in fishing and boating.



▲ Raw water washdown w/coil hose (location varies by model)



▲ Freshwater cockpit shower (location varies by model)



▲ Bow casting platform insert, insert cushions and fish box cushions



▲ Bow pulpit shown with anchor windlass option



▲ Stereo/CD system



▲ Large swim platform



▲ Small swim platform



▲ Dockside power (part of a convenience package)



▲ Companion bench seat (300 shown)



▲ Deluxe helm chair



▲ Raw water livewell (lean bar option)



▲ Outrigger kit, Radial Top Gun T-top Mounted



▲ Cabin rod racks



▲ Trim tabs



▲ Tilt steering (mechanical or hydraulic)

Factory Rig Your Choice of Outboard Whatever your engine of choice, Grady-White can provide factory pre-rigging so engine controls, wiring and instrumentation are installed while your boat is built. Grady-Built quality ensures that your engine installation delivers optimum performance. We stand behind our work: pre-rigging is covered under Grady-White's factory warranty.



▲ Walkaround series vista top and side curtains



▲ Center console Bimini top



▲ Tournament series vista top and side curtains



▲ Portable head



▲ Head with holding tank

Grady-Built: Engineered for exceptional safety and value.



Anchor locker with rope storage

Double through bolting on threshold of cabin

Automobile type adjustable seats have integrated hand holds.

Insulated fish boxes and ice boxes are above the waterline and drain overboard, never into the bilge. Gutter systems are built into all exterior storage spaces.

Toe rails secure your feet when you lean over the side.

Weather resistant polyethylene rod racks

Engine pre-rigging is installed at the factory and custom fitted to your boat.

Through-bolted upright rod holders are chrome-over-bronze.

Transducer mounting flats are molded in on some models.

Through-bolted 316 stainless steel hardware is secured with locking nuts.

Safety glass windshields

Grab rails are at your fingertips at the helm, in the cockpit, walkaround area and when you climb back onboard after a swim.

Storage is engineered with functionality in mind. We aim to ensure that Grady-Whites have the most storage of any boat in their category.

Solid 100% hand laid hulls and decks provide uniform laminate structure, strength and durability.

Stainless steel screws and blindside fasteners join the hull and liner to the deck with polyethylene gaskets sealed with silicone. Stainless screws secure the heavy duty gunwale molding.

Liner is bonded to the stringer system and hull with fiberglass.

All Grady-Whites have foam sprayed into the hull for level (models 180, 192) or basic flotation, even though not required in boats over 20 feet. This foam also adds strength, thermal insulation and deadens sounds.

No-rot stringer system is encapsulated in resin and fiberglassed to the hull.

Protected rigging with factory installed PVC tubing

Nonskid self-bailing cockpit directs water overboard whether at rest or underway. All scuppers drain overboard. Inspection ports are watertight. All Grady-Whites have automatic bilge pumps, with two pumps on cabin models over 20 feet. Our dedication to self-bailing cockpit integrity is unparalleled.

5/16" aluminum transom brace is bonded to the top of outboard transoms, which reinforces transom strength and distributes motor torque. On integrated bracket models, the brace is through bolted to the longitudinal stringer system.



*Ranking resulted from J.D. Power and Associates 2001 Marine Quality and Performance Study™. Study based on responses from a total of 5,979 owners of 2000 model-year boats. www.jdpower.com

Grady-White Boats, PO Box 1527, Greenville, NC 27835 (252) 752-2111 www.gradywhite.com Grady-White Boats, Inc. reserves the right to discontinue models, or change prices, specifications, materials, equipment, colors or design at any time without incurring obligation. Weight and dimensions of all models

J.D. Power and Associates ranks* Grady-White: **Highest in Customer Satisfaction with Center Console Boats**
Center Console Boats include Dual Console,